

# InterReach Spectrum™

One Solution for your Wireless Services



## In-Building Wireless Distributed Antenna System

InterReach Spectrum is used to extend wireless services throughout a building, multiple buildings, or campus. It is the market's most flexible, scalable and complete solution for addressing coverage and capacity needs for current and emerging wireless networks. This distributed antenna system (DAS) features unique, patented technology that distributes wireless coverage and capacity digitally through an optical fiber backbone for superior voice and data quality, flexibility, and overall performance. It's digitized optical transport along with its thin-cabling distributed amplifier architecture future-proofs your in-building wireless network for high data rate services. InterReach Spectrum offers service providers and enterprise users a flexible, scalable, multi-band, multi-protocol solution to improve user satisfaction by delivering the signal strength required to meet increasing subscriber demands.



## Market Trends



With the increased proliferation of mobile devices and the unprecedented growth in wireless applications, subscribers expect to have wireless service any place they go. Providing seamless service everywhere can be challenging, particularly inside of buildings where we've come to rely on mobile communication the most.



The onset of high speed data services requires service providers to design their networks differently, resulting in an increased priority for indoor coverage. Data download times are becoming the hot-button service topic that dropped calls once were. Exacerbating this, third and fourth generation networks will result in smaller cell sizes, causing the macro network coverage to be insufficient for thoroughly penetrating buildings. And since mobile usage is greatest indoors, dedicated indoor solutions can also improve macro network performance as it offloads capacity from the cell site.



In-building wireless needs are everywhere—in enterprises, university and corporate campuses, inside of public buildings such as malls, stadiums, airports, and hotels. While there are many choices for providing improved in-building wireless service, it's imperative to consider the long-term costs, benefits and limitations of solutions. Given the constant changes in the communications landscape, the best investment is in the system that offers you the most flexibility, scalability, reliability, and performance quality for legacy and emerging networks.

# InterReach Spectrum™

## One Solution for your Wireless Services

### Enterprise

Most large enterprise buildings require upwards of sixty or more antenna locations to provide adequate service throughout their property. Passive systems are not suited to distribute signal over such a span. The loss sustained in transport will be insufficient for voice service, and woefully under-serve data applications. Additionally, the model of how mobile service enhancements are done within a business has been changing. Historically, a wireless service provider might provide an in-building wireless solution as part of the terms of their user agreement. Today, enterprises may have contracts with more than one vendor in their market area and are beginning to think of their wireless network as an extension of their own private network. They look for solutions, like Spectrum, that provide them the flexibility to support the service provider relationships they have and the business applications to make them successful now and in the future.

### Large Public Venue

Large public venues are the new frontier for in-building wireless. Roadside coverage is by the wayside as we shift from mobility to portability. Subscribers use their down time in public places like airports, subway stations, and clinics as their mobile office. At malls and in stadiums, texts, photos, GPS and mobile video are now a part of the user experience. And, those in the real estate, education and hospitality industry look to wireless as the latest amenity— attracting customers and as a safety and security measure. The ideal solution in this broad group is the one that's most flexible and can be architected to meet the needs of the end-user (enterprise, property manager) and the area service providers.

### Multi-Tenant High Rise

Like public venues, the ideal solution is the one that's most flexible and can be architected to meet the needs of the various end-user enterprises, the property manager, and the area service providers. Spectrum offers the flexibility to scale with the property as-needed. The system's scalability is ideal to meet the needs of multiple stakeholders and support whatever commercial terms they require. The cable backbone can be shared and the system can scale to support the specific service needs of a given tenant inside of their space.

### Stadium

Stadiums are some of the most complex wireless environments. The capacity demands at events are unlike any other—photos, video replay, texts and calls... and create a huge revenue opportunity for the wireless service provider. But, the physical construction makes it challenging to deliver network performance on par with the macro network. Built of concrete and including a mix of large open air spaces, tunnels, corridors, and subterranean spaces, make stadiums an ideal environment for Spectrum. Spectrum has the capacity to deliver the multiple services needed to support the crowd and the flexibility to reach all areas inside of these complex indoor/outdoor environments. By cascading elements and using a mix of high and low power remotes, TE delivers the right mix of precision coverage and capacity for these venues.

### Campus

TE's in-building solution provides ubiquitous service throughout an entire campus. Our hybrid indoor/outdoor approach uses any combination of Spectrum and Prism Remotes to provide blanket service from the inside out or to augment service "holes" in and around your buildings. We begin by distributing higher power Prism Remotes throughout the campus to cover outdoor, semi-open structures and large venues such as stadiums. This is followed by backfilling indoor corridors, subterranean levels and other in-building areas the outdoor network does not reach. This design strategy offers greater than 30% savings compared to an all indoor approach and users have seamless reliability as they move in and around the property.

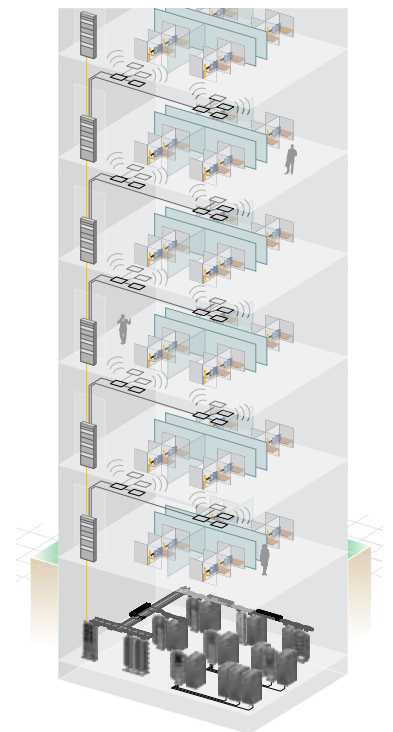

# InterReach Spectrum™

One Solution for your Wireless Services

## System Description

Spectrum supports legacy licensed mobile services and emerging technologies. It provides edge-to-edge bandwidth and multi-band flexibility. Spectrum also offers industry-leading element management that includes on-site or remote accessible system alarming and management of network elements and the cable infrastructure. Spectrum is a scalable platform that allows for easy system growth in size and scope of solution, whether the system needs to scale to reach new service areas inside of buildings or add bandwidth and capacity as necessary.

Spectrum can be designed to suit any size and shape property. Unlike any other solution available, the Expansion Units may be cascaded to provide overall system growth. If your property or wireless needs change, the system can change with you. Spectrum's system modularity of main components and its field-upgrade ability make it the most cost-optimized solution on the market.

The InterReach Spectrum DAS consists of three main component types: Host, Expansion Module Group (EMG), and Remotes. The Host serves as an interface to the RF source. The Host digitizes the RF inputs and transmits those over fiber optic cable to EMG. The Expansion Module Groups convert the signal to RF and distribute the signal and power over thin coaxial CATV cable to Remote Units. The Remote Units are distributed throughout the property where the service improvement benefits

are greatest. Remotes are hidden from view, typically above ceiling tile, and paired with wideband antennas to provide the greatest level of service. Unlike other wideband solutions on the market, Spectrum may be designed with shared or discrete power amplifiers for service providers sharing a particular frequency block. All frequency bands may be simultaneously active at each antenna port or only at desired antenna locations. This distributed amplifier design offers the greatest power output (minimizing the number of antenna locations), serviceability, and flexibility to optimize the network based on each band's capacity requirements and coverage footprint. Additional band pairs (Secondary Remotes) may be added as new services are launched in a market.

This flexibility allows for maximum network design optimization. It also accommodates a variety of business models in applications where the system is supporting multiple wireless service providers. Cable infrastructure and Spectrum Hosts, EMGs and Remote units or their sub-modules may be purchased or supported by one or multiple entities.

InterReach Spectrum is the leading solution for true multi-band support whether the solution supports a single service provider or multiple service providers. With its unique flexibility and scalability, it is the best in-building wireless system for large venues and campus applications.

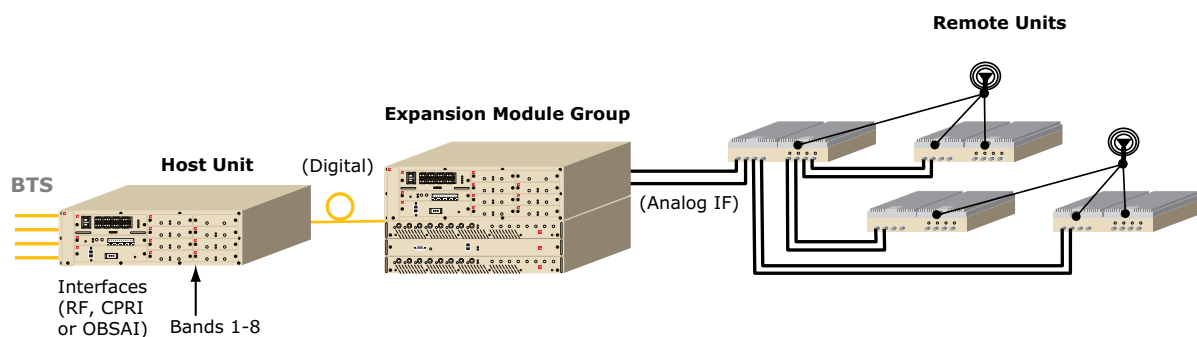

# InterReach Spectrum™

One Solution for your Wireless Services

---

## Digitized Transport

InterReach Spectrum and its outdoor DAS sister solution, FlexWave Prism, use patented digital-over-fiber technology to distribute RF to desired service locations. Spectrum digitizes the entire designated RF band and/or multiplexes direct digital CPRI or OBSAI feeds over dark fiber. The signal is reconstructed at full bandwidth, regardless of modulation technology. TE's digital RF transport allows signals to be replicated at full dynamic range, independent of the fiber link length, for improved data throughput. As service providers migrate to 3G and 4G networks and high data rate broadband services, networks using Spectrum and Prism will be ready.

Digital transport also offers the lowest possible noise level. Not only are signals able to travel longer distances between the RF source and the antenna location, they are unaffected by splices and signal splits. The true maximum output power is available at the antenna location, unlike direct modulated fiber transport systems or all coax-based systems. At every network change, those systems will incur performance loss and re-engineering will be required to keep up with user service expectations, making lifetime costs on these solutions greater than your investment in a system suited for 2G, 3G and 4G combined.

Digital RF transport provides the greatest flexibility for supporting your legacy and emerging network as well as your indoor and outdoor networks.

## FEATURES AND BENEFITS

- Flexible
  - Supports multiple frequency bands and wireless protocols in one system (2G, 3G, 4G)
  - Air interface independent
  - System modularity to add and grow
  - Supports up to 8 bands in non-contiguous segments of 1.5 to 75 MHz each
  - BTS interface supporting RF and CPRI/OBSAI standards
  - Field upgradable
- Optimized System Design
  - Star and Cascaded topologies
- Simplified Management and Support
  - Spectrum and Prism software, alarming, configuration and maintenance through one platform; web-based and SNMP
  - Common hardware with Prism
  - Simplifies procurement, reduces spares kit and simplifies installation
- Scalable
  - Add bands, protocols by adding DART cards and Remotes
  - Cascade Expansion Units when coverage extension is needed
  - No need to pull added CATV in ceiling for additional bands
- Performance
  - Digital transport maintains superior signal quality even over long distance fiber runs
  - High dynamic range increases capability for data throughput, enabling higher rate broadband services

# InterReach Spectrum™

One Solution for your Wireless Services

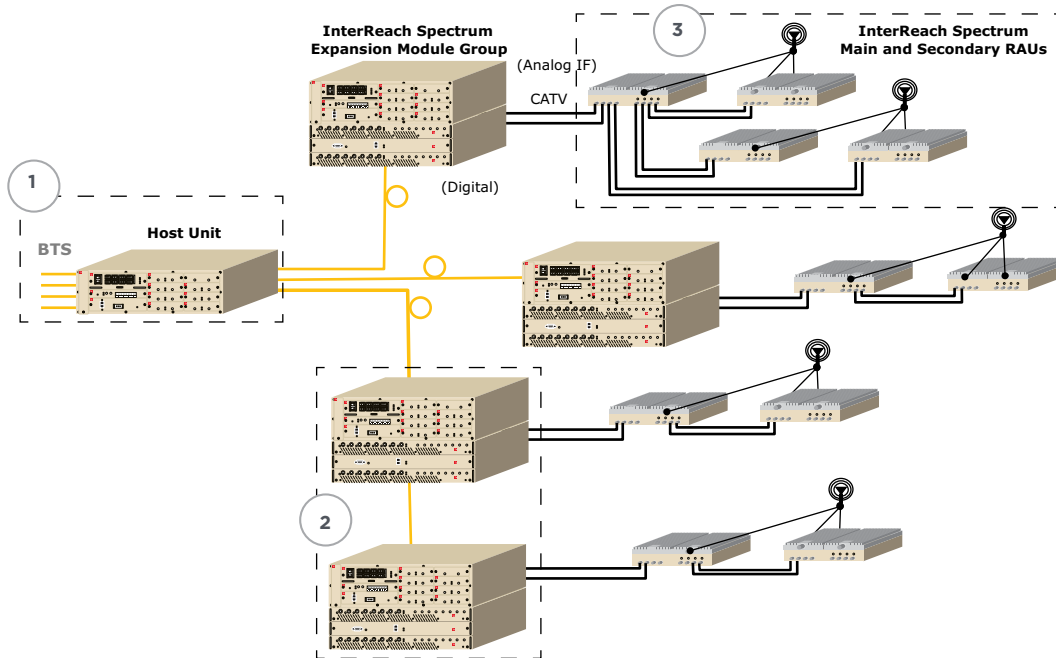

**1** The Host Unit feeds InterReach Spectrum in-building DAS Remotes.

- Perfect for large venues, enterprises, and campus applications
- Flexible, scalable architecture
- Digital transport for superior signal quality over fiber.

**2** Expansion Module Groups can be cascaded to offer unparallelled system growth

- Eliminating fiber "home runs"
- Maximizing lateral reach for sprawling properties
- Eliminating the need for overlay systems and redundant systems on campuses

**3** Remote Unit modularity easily scales to accommodate parallel amplifiers for additional frequencies

- Maximizing output power for each service, less antenna locations
- Building in redundancy for single-band services
- Supports up to four RAUs at each antenna location

# InterReach Spectrum™

One Solution for your Wireless Services

## Host Unit

The rack-mountable InterReach Spectrum Host Unit is typically located with an RF source, a Base Station(s) or a repeater. On the forward path, the Host Unit receives the RF signals from the BTS and digitizes the designated RF bands and digitally transports them over single mode fiber to the Expansion Units. On the reverse path, the Host Unit receives the digitized RF signals from the Expansion Unit and converts them back to RF for the BTS. The Spectrum Host Unit is completely modular in design. Digital/Analog Radio Transceiver (DARTS) cards are hot swappable providing easy upgrades to additional bands without interrupting existing service.

The Spectrum Host Unit supports up to eight DART cards (supporting up to eight BTS interfaces) and is capable of simulcasting signals to dozens of antennas. DART cards are available in either 35 MHz non-contiguous bandwidth or 75 MHz full bandwidth.

A Single SuperDART supports 35 MHz of non-contiguous to 75 MHz of total bandwidth for a given service. For example, PCS is 65 MHz wide. The Single SuperDART supports from 5 MHz to 65 MHz of total bandwidth range, including two non-contiguous slices. The Single SuperDART uses a single DART position in the Host.



Host Unit

The Host Unit utilizes an embedded element management system for system configuration and network monitoring. The embedded EMS collects alarm information from the entire system.

In addition to sending alarm notifications to the Element Management System (EMS) through software, the Host Unit also features front panel alarm reporting. LEDs on the front panel of the Host Unit will change color depending on the status of the unit. LED displays provide information regarding the following items:

- Power
- System mode (active/standby)
- Indicate unit fault condition
- RF conditions

# InterReach Spectrum™

## One Solution for your Wireless Services



Expansion Module Group



Remote Unit

### Expansion Module Group

The InterReach Spectrum Expansion Module Group receives the digitized RF signal from the Host Unit and is responsible for distributing that signal to the Remote Access Units (RAUs). The Expansion Module Group is the driver of Spectrum's architectural flexibility and system scalability. The Expansion Module Group has two main components.

One component is a 19" rack-mounted Dart Remote Unit (DRU) chassis that is 3U high and 9" deep with eight hot-swappable plug-in cards; these are called the IF DART modules. These IF DART modules drive the RAUs via the IF Expansion Unit. It also includes one serial RF (SeRF) board with eight optical small form pluggable connectors that connect to the Host Unit. There are also two Ethernet connections and a System Alarm connector on the device.

The second component is a 19" rack-mounted IF Expansion Unit chassis that is 3U high and 15" deep with 3 plug-in cards. These include:

- A Downlink FWD Module with eight F connectors (To RAUs) and eight QMA connectors (To DART Remote Unit),
- One Uplink REV Module with 8 F type (To RAUs) and 8 QMA connectors (To DRU),
- One Micro controller board and DC/DC board.

The Expansion Module Group also has replaceable fans for system cooling. It is typically mounted in a rack inside of a telecom closet.

### Remote Units

InterReach Spectrum supports up to 8 bands in a single system. Each antenna location supports those bands in modular, group pairings. Each location includes a Main Remote Access Unit (RAU) that can power up to three additional Secondary RAUs (each supporting two power amplifier pairs for a total of eight amplifiers). These Main and Secondary RAUs are grouped logically based on common service provider groupings and include: 850/1900, 700/700 MIMO, 800/900 SMR, 700 SISO/AWS, and 800/AWS. Adding frequency is as simple as plugging in a Secondary RAU (SRAU) to the existing Main RAU (MRAU).

RAUs are available in two different output power options - standard and high power. These can be 'mix and matched' on a system to meet the specific needs of a venue.

Since Spectrum can be configured to support as many as four cascaded runs of sixteen total Expansion Module Groups, the system configuration possibilities are seemingly endless and can scale to single systems that include as many as 128 Main RAU locations. With each of those locations supporting between one and eight RF bands. And each of those band locations offers 26 dBm (P1dB) or 31 dBm (P1dB) of output power based on selecting standard or High Power (HP) RAUs.

The system may be scaled to add new bands or RAU location sites as-needed and offers great service flexibility and performance relative to shared, wide-band amplifier systems. Each service provider may control their band of interest and enjoy the predictability in consistent service at each RAU location independent of what other operators are doing or the length the signal travels to the service area.

The RAUs are typically mounted above ceiling tiles or in out-of-sight locations as close as possible to the service area.

# InterReach Spectrum™

## One Solution for your Wireless Services

### Alarm and Management System

InterReach Spectrum utilizes an embedded network management for system configuration and network monitoring. The Element Management System (EMS) utilizes a web based interface or SNMP protocol for easy accesses to the system.

The EMS provides operational and maintenance capabilities for the Spectrum system. The system provides end-to-end alarming from the Host all the way through to the passive antenna, including the cable infrastructure. The EMS can be used to set up and monitor status of any Host and any associated Expansion and Remote Units. The EMS has the ability to configure the system, view status and parameter settings, download software, change parameters and monitor system performance and alarms.

Access and troubleshooting can also be accomplished on-site at either the Host Unit and/or the Remote Unit by utilizing a craft interface. Thus, allowing technicians the ability to plug-in a laptop and access all associated units connected to it.

### Host Site Capabilities

The EMS performs the following functions at the Host site:

- Provides real-time information regarding faults
- Set up simulcast ratios
- Digital timing delays
- Displays various system level values (voltages, RF, power, etc.)
- Records and generates history reports with time and date stamps
- Adjusts performance related parameters of the system
- Permits placement of system into standby mode
- Allows download of new software versions



**System Status View**

### Network Monitoring Capabilities

The embedded EMS allows for remote alarm monitoring and network control of the system can also be performed from an off-site location or Network Operation Center (NOC). Communications to the NOC can be performed using the web based interface or SNMP protocol.

The EMS performs the following functions at off-site locations such as the NOC:

- Provides real-time information regarding faults
- Displays various system level values (voltages, RF, power, etc.)
- Adjusts performance-related parameters of the system
- Permits placement of the system into standby mode
- Access records and generates history reports with time and date stamps
- Allows download of new software versions



**System Configuration View**

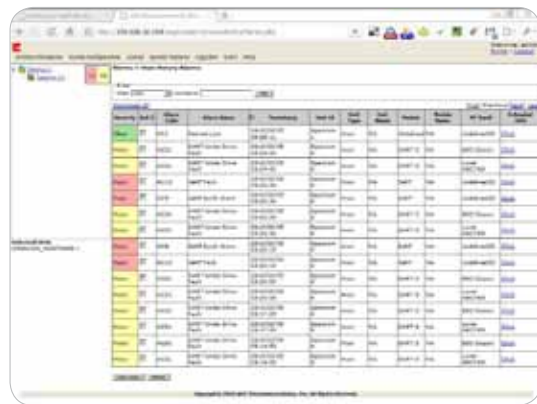

**Alarm History View**



# InterReach Spectrum™

One Solution for your Wireless Services

## SPECIFICATIONS

RF	Low/Medium Power Level 700-900 MHz Typical		Low/Medium Power Level 1900-2100 MHz Typical		High Power Level 1900-2100 MHz Typical	
	TX	RX	TX	RX	TX	RX
<b>Average gain</b> with 180 m CATV at 25°C (77° F) (dB):	40 <sup>1</sup> /43 <sup>2</sup>	30	40 <sup>1</sup> /43 <sup>2</sup>	30	48	30
<b>Ripple with 180 m CATV (dB):</b>	2.5	3.0	3.5	4.0	3.5	4.0
<b>Output IP3 (dBm):</b>	38		38		43	
<b>Input IP3 (dBm):</b>		-8		-8		-8
<b>Output 1 dB Compression Point (dBm):</b>	26		26		31	
<b>Noise Figure 1 HU-1 EMG-8 RAUs (dB):</b>		17		17		17
<b>Noise Figure 1 HU-4 EMG-32 RAUs (dB):</b>		23		23		23

1. Low Power is defined here as a standard main RAU used with standard secondary RAUs.

2. Medium Power is defined here as a high power main used with standard secondary RAUs

PHYSICAL	HOST UNIT/DART REMOTE UNIT	IF EXPANSION UNIT	REMOTE ACCESS UNIT
<b>RF/IF Connectors:</b>	1 QMA TX/RX pair / per RF DART Card / 1 QMA TX/RX pair per IF DART Card	8 QMA per IF TX Card  8 QMA per IF RX Card	1-2 N, female pair per Main (antenna - 50 ohms)
<b>Secondary:</b>		8 F, female TX per TX card 8 F, female RX per RX car	4 F, female pair per Main 2 F, female pair per Secondary
<b>External Alarm:</b>	Terminal plug connector	—	—

## CONNECTOR

### (CONTACT CLOSURE)

<b>ADMIN/LAN:</b>	1 RJ-45, female	—	—
<b>Fiber Connectors:</b>	8 SFP Transceivers using Duplex LC flat polished UPC	—	—
<b>DC Power (Volts):</b>	±24-60 VDC	+51-57 VDC	+54 VDC (from IFEU) over CATV
<b>AC Power (Volts) Using Spectrum External AC/DC Power Supply:</b>	90-264 VAC	90-264 VAC	—
<b>Power Consumption (W):</b>	215 Typical, 8 DARTS	4 MRAUs and 4 SRAUs 400 typical 8 MRAUs and 24 SRAUs 1600 typical	—
<b>Input Current, Full Load:</b>	Included with IFEU	15/30A@120VAC (Rectifier Modules 1/2)	
<b>VAC Circuit Required:</b>	Included with IFEU	2 - 20A 120VAC/10A 240VAC  (1 per Rectifier Module) 25A@54.4VDC	
<b>DC Power (Volts) Using Spectrum External DC/DC Power Supply:</b>	40-60 VDC	40-60 VDC	—
<b>Power Consumption (W):</b>	215 Typical, 8 DARTS	4 MRAUs and 4 SRAUs 400 typical 8 MRAUs and 24 SRAUs 1600 typical	—
<b>Input Current, Full Load:</b>	Included with IFEU	50A@40VDC	

# InterReach Spectrum™

One Solution for your Wireless Services

---

## ENCLOSURE DIMENSIONS

<b>Rack Mountable:</b>	5.25" x 19.00" x 12.00" (13.34 cm x 48.26 cm x 48.26 cm)	5.25" x 17.11" x 11.93" (13.34 cm x 43.46 cm x 30.30 cm)	3.50" x 9.00" x 11.50" (8.90 cm x 22.86 cm x 29.21 cm)
<b>Weight:</b>	< 25 Pounds	< 19.5 Pounds	<7.50 Pounds

## ENVIRONMENTAL:

<b>Operating Temperature:</b>	0 to +50° C 32 to 122° F	0 to +50° C 32 to 122° F	-25 to +50° C -13 to 122° F
<b>Non-operating Temperature:</b>	-40 to +70° C	-40 to +70° C	-40 to +70° C
<b>Operating Humidity; Non-condensing:</b>	5% to 95%	5% to 95%	5% to 95%

## CABLING

<b>Optical Fiber:</b>	These specifications assume that the fiber optic cable, singlemode or multimode, is Corning with duplex LC flat polished UPC connectors
<b>Optical Power Budget:</b>	Uplink and Downlink Maximum: 13 dBo with intermediate range SFP, and 26 dBo with long range SFP, Maximum multimode fiber distance is 500 meters. Multimode fiber requires MMF SFPs.  Optical loss = fiber loss + connector losses + splice losses + patch cord losses
<b>CATV:</b>	The specifications in this document assume that CATV RG-6 cable is Belden 1695 and CATV RG-11 cable is Belden 7732 or equivalent, with 75 ohm F connectors.
<b>CATV Lengths:</b>	Minimum: 0 meters (0') Maximum: 125 m (410') with RG-6 Maximum: 180 m (590') with RG-11
<b>Compliance Safety:</b>	UL, CSA, CB Scheme certificate to IEC 60950, 3rd Edition, and IEC 60950-1, 1st Edition, with all national deviations
<b>EMC:</b>	FCC part 15 class A
<b>Radio:</b>	FCC part 22, part 24, part 27, part 90
<b>Class 1 Laser Products:</b>	IEC 60825-1:1998-01 and IEC 60825-2:2000-05

## Lower Power Level

Standard Main RAU with Secondary RAUs

		Power per Carrier (dBm) per Band						
		RF Frequency		Number of RF Carriers				
		TX	RX	1 P-out	2 P-out	4 P-out	8 P-out	
<b>Standard MRAU</b> SPT-M1-8519-1 SPT-M1-AWS19-11	<b>850 Cell</b>	869-894	824-849	26.0	20.0	14.0	9.0	GSM
				23.0	17.5	12.0	8.0	EDGE
				15.0	12.0	9.0	6.0	CDMA
				15.0	12.0	9.0	6.0	WCDMA
				15.0	12.0	9.0	6.0	LTE
<b>Standard SRAU</b> SPT-S1-8090-1 SPT-S1-7070-1-MIMO SPT-S1-80AWS-1 SPT-S2-70AWS-1-SISO SPT-S2-70AWS-22-SISO	<b>800 SMR</b>	851-869	806-824	17.5	14.0	10.0	6.5	iDEN
				26.0	19.5	13.5	8.5	APCO 25 C4FM
				15.0	12.0	9.0	6.0	CDMA
				15.0	12.0	9.0	6.0	LTE
	<b>900 SMR</b>	935-940	896-901	17.5	14.0	10.0	6.5	iDEN
				26.0	19.5	13.5	8.5	APCO 25 C4FM
SPT-S1-AWS19-12 SPT-S1-2121-1-MIMO SPT-S1-8019-22 SPT-S1-8519-22	<b>1900 PCS</b>	1930-1995	1850-1915	26.0	20.0	14.0	9.0	GSM
				23.0	17.5	12.0	8.0	EDGE
				15.0	12.0	9.0	6.0	CDMA
				15.0	12.0	9.0	6.0	WCDMA
				15.0	12.0	9.0	6.0	LTE
	<b>2100 AWS</b>	2110-2155	1710-1755	15.0	12.0	9.0	6.0	WCDMA
				15.0	12.0	9.0	6.0	LTE
	<b>700 Upper C</b>	746-757	776-787	15.0	12.0	9.0	6.0	LTE
	<b>Lower ABC</b>	728-746	698-716					

## Medium Power Level

Spectrum Standard Secondary RAUs when used with the HP MRAU<sup>1</sup>

		Power per Carrier (dBm) per Band						
		RF Frequency		Number of RF Carriers				
		TX	RX	1 P-out	2 P-out	4 P-out	8 P-out	
<b>Standard SRAU:</b> SPT-S1-8090-1 SPT-S1-7070-1-MIMO SPT-S1-80AWS-1 SPT-S2-70AWS-1-SISO SPT-S2-70AWS-22-SISO SPT-S1-AWS19-12 SPT-S1-2121-1-MIMO SPT-S1-8019-22 SPT-S1-8519-22	<b>850 Cell</b>	869-894	824-849	26.0	20.0	14.0	9.0	GSM
				23.0	17.5	12.0	8.0	EDGE
				18.0	15.0	12.0	9.0	CDMA
				18.0	15.0	12.0	9.0	WCDMA
				18.0	15.0	12.0	9.0	LTE
	<b>800 SMR</b>	851-869	806-824	17.5	14.0	10.0	6.5	iDEN
				26.0	19.5	13.5	8.5	APCO 25 C4FM
				18.0	15.0	12.0	9.0	CDMA
				18.0	15.0	12.0	9.0	LTE
	<b>900 SMR</b>	935-940	896-901	17.5	14.0	10.0	6.5	iDEN
				26.0	19.5	13.5	8.5	APCO 25 C4FM
	<b>1900 PCS</b>	1930-1995	1850-1915	26.0	20.0	14.0	9.0	GSM
				23.0	17.5	12.0	8.0	EDGE
				18.0	15.0	12.0	9.0	CDMA
				18.0	15.0	12.0	9.0	WCDMA
				18.0	15.0	12.0	9.0	LTE
	<b>2100 AWS</b>	2110-2155	1710-1755	18.0	15.0	12.0	9.0	WCDMA
	18.0			15.0	12.0	9.0	LTE	
<b>700 Upper C</b>	746-757	776-787	18.0	15.0	12.0	9.0	LTE	
<b>Lower ABC</b>	728-746	698-716						

<sup>1</sup> See power per carrier of HP MRAU from High Power level table on page 13.

## High Power Level

Spectrum HP Main RAU with HP Secondary RAUs

		Power per Carrier (dBm) per Band						
		RF Frequency		Number of RF Carriers				
		TX	RX	1 P-out	2 P-out	4 P-out	8 P-out	
<b>HP_MRAU</b> SPT-M3-8518-11-HP SPT-M3-8019-31-HP	<b>850 Cell</b>	869-894	824-849	26.0	20.0	14.0	9.0	GSM
				23.0	17.5	12.0	8.0	EDGE
				18.0	15.0	12.0	9.0	CDMA
				18.0	15.0	12.0	9.0	WCDMA
				18.0	15.0	12.0	9.0	LTE
<b>HP_SRAU</b> SPT-S3-70AWS-11-HP SPT-S3-70AWS-22-HP SPT-S3-2626-12-HP SPT-S3-8019-22-HP SPT-S3-8519-22-HP	<b>800 SMR</b>	851-869	806-824	17.5	14.0	10.0	6.5	iDEN
				26.0	19.5	13.5	8.5	APCO 25 C4FM
				18.0	15.0	12.0	9.0	CDMA
				18.0	15.0	12.0	9.0	LTE
	<b>900 SMR</b>	935-940	896-901	17.5	14.0	10.0	6.5	iDEN
				26.0	19.5	13.5	8.5	APCO 25 C4FM
	<b>1900 PCS</b>	1930-1995	1850-1915	26.0	23.0	19.0	14.0	GSM
				26.0	22.5	17.0	13.0	EDGE
				23.0	20.0	17.0	14.0	CDMA
				23.0	20.0	17.0	14.0	WCDMA
				23.0	20.0	17.0	14.0	LTE
	<b>2100 AWS</b>	2110-2155	1710-1755	23.0	20.0	17.0	14.0	WCDMA
				23.0	20.0	17.0	14.0	LTE
	<b>2600</b>	2620-2690	2500-2570	23.0	20.0	17.0	14.0	WCDMA
				23.0	20.0	17.0	14.0	LTE
	<b>700 Upper C</b>	746-757	776-787	18.0	15.0	12.0	9.0	LTE
	<b>Lower ABC</b>	728-746	698-716					

### ORDERING INFORMATION

Description	Catalog Number
<b>Spectrum Host Unit</b>	
Spectrum-Prism Host unit - No DARTs	FWP-00000HUII
Spectrum-Prism, 800 SMR, Classic RF DART	FWU-40000HUDART
Spectrum-Prism, 900 SMR, Classic RF DART	FWU-50000HUDART
Spectrum-Prism, 850 CELL, Classic RF DART	FWU-20000HUDART
Spectrum-Prism 1900 PCS, Single RF SuperDART	FWU-86000HUDART
Spectrum-Prism 2100 AWS, Single RF SuperDART	FWU-A6000HUDART
Spectrum-Prism 2600 LTE, Single RF SuperDART	FWU-N6000HUDART
Spectrum-Prism 700 LTE Lower ABC, Single RF SuperDART	FWU-L6000HUDART
Spectrum-Prism 700 LTE Upper C, Single RF SuperDART	FWU-U6000HUDART
<b>Spectrum DART Remote Unit</b>	
Spectrum DART Remote Unit - No IF DARTS	SPT-0000DRUII
Spectrum, 800 SMR, IF DART	SPT-00800SMRIFD
Spectrum, 800 SMR, Path-2, IF DART	SPT-0800SMRP2IFD
Spectrum, 800 SMR, Path-3, IF DART	SPT-0800SMRP3IFD
Spectrum, 900 SMR, IF DART	SPT-000900SMRIFD
Spectrum, 850 CELL, IF DART	SPT-000000850IFD
Spectrum, 850 CELL, Path-2, IF DART	SPT-0000850P2IFD
Spectrum, 1900 PCS, IF DART	SPT-000001900IFD
Spectrum, 1900 PCS, Path-2, IF DART	SPT-0001900P2IFD
Spectrum, 2100 AWS, Path 1, IF DART	SPT-2100AWSP1IFD
Spectrum, 2100 AWS, Path 2, IF DART	SPT-2100AWSP2IFD
Spectrum, 2600 LTE, Path 1, IF DART	SPT-0002600P1IFD
Spectrum, 2600 LTE, Path 2, IF DART	SPT-0002600P2IFD
Spectrum, 700 UpperC Path-1, IF DART	SPT-00700UCP1IFD
Spectrum, 700 UpperC Path-2, IF DART	SPT-00700UCP2IFD
Spectrum, 700 LowerABC Path-1, IF DART	SPT-700LABCP1IFD
Spectrum, 700 LowerABC Path-2, IF DART	SPT-700LABCP2IFD

# InterReach Spectrum™

One Solution for your Wireless Services

## ORDERING INFORMATION

Description	Catalog Number
<b>Spectrum IF Expansion Unit</b>	
Spectrum IF Expansion Unit	SPT-00000IFEU-1
Spectrum AC Input Power Supply (with 2-1200W modules)	SPT-2400ACDC-1
Spectrum DC Input Power Supply (with 2-1000W modules)	SPT-2000DCDC-1
<b>Spectrum Standard Remote Access Unit (RAU)</b>	
850p1-1900p1 Main RAU	SPT-M1-8519-1
AWS p1-1900p1 Main RAU	SPT-M1-AWS19-11
1900p2-AWSp1 secondary RAU	SPT-S1-AWS19-12
800p1-900p1 SMR secondary RAU	SPT-S1-8090-1
700 MIMO Upper C/Lower ABC secondary RAU	SPT-S1-7070-1-MIMO
800p1-AWSp1 secondary RAU	SPT-S1-80AWS-1
700p1 uC/LABC SISO-AWSp1 secondary RAU	SPT-S2-70AWS-1-SISO
700p2 uC/LABC SISO-AWSp2 secondary RAU	SPT-S2-70AWS-22-SISO
850p2-1900p2 secondary RAU	SPT-S1-8519-22
AWS MIMO AWS secondary RAU	SPT-S1-2121-1-MIMO
800p2-1900p2 secondary RAU	SPT-S1-8019-22
<b>Spectrum High Power Remote Access Unit (RAU)</b>	
Spectrum, 850p1 -1900 HPP1 Main RAU	SPT-M3-8519-11-HP
Spectrum, 800p3 -1900 HPP1 Main RAU	SPT-M3-8019-31-HP
Spectrum, 700 p1 uC/LABC -AWS HPP1 Secondary RAU	SPT-S3-70AWS-11-HP
Spectrum, 700p2 uC/LABC -AWS HPP2 Secondary RAU	SPT-S3-70AWS-22-HP
Spectrum, 850p2 - 1900 HPP2 Secondary RAU	SPT-S3-8519-22-HP
Spectrum, 800p2 - 1900 HPP2 Secondary RAU	SPT-S3-8019-22-HP
Spectrum, 2600HPP1 - 2600 HPP2 Secondary RAU	SPT-S3-2626-12-HP

Contact your TE representative for ordering information.

## DATA SHEET



**Contact us:**

P.O. Box 1101  
Minneapolis, Minnesota  
USA 55440-1101  
Tel: 1-800-366-3891  
Fax: 1-952-917-3237

[www.te.com/WirelessSolutions](http://www.te.com/WirelessSolutions)

TE Connectivity, TE connectivity (logo), Tyco Electronics, and TE (logo) are trademarks of the TE Connectivity Ltd. family of companies and its licensors.

While TE Connectivity has made every reasonable effort to ensure the accuracy of the information in this document, TE Connectivity does not guarantee that it is error-free, nor does TE Connectivity make any other representation, warranty or guarantee that the information is accurate, correct, reliable or current. TE Connectivity reserves the right to make any adjustments to the information contained herein at any time without notice. TE Connectivity expressly disclaims all implied warranties regarding the information contained herein, including, but not limited to, any implied warranties of merchantability or fitness for a particular purpose. The dimensions in this document are for reference purposes only and are subject to change without notice. Specifications are subject to change without notice. Consult TE Connectivity for the latest dimensions and design specifications.

Tyco Electronics Corporation, a TE Connectivity Ltd. Company. All Rights Reserved.

109021AE 9/13 Revision © 2013, 2012, 2010