

DPX-54x

Diplexer | 1427-1496 MHz/1710-2170 MHz | Single and Twin Units | Indoor / Outdoor

- Combines the 1427-1496 MHz and 1710-2170 MHz bands into a single output
- Usable at the BTS or antenna end
- Built in lightning protection on all ports
- Available as single or twin unit, with Auto-Sense or various DC/AISG bypass configurations
- Suitable for indoor or outdoor applications
- Pole or wall mounting
- Available with 7/16-DIN or 4.3-10 female connectors



Ordering Options	Single Unit		Twin Unit	
	7/16-DIN	4.3-10	7/16-DIN	4.3-10

When ordering replace "x" with correct option for bypass configuration and single or twin unit.

With DC/AISG Auto-Sense	DPX-54A	DPX-54A-43F	DPX-54AA	DPX-54AA-43F
DC/AISG bypass from common to high band only	DPX-544	DPX-544-43F	DPX-545	DPX-545-43F
DC/AISG bypass from common to low band	DPX-546	DPX-546-43F	DPX-547	DPX-547-43F
Full DC/AISG bypass	DPX-542	DPX-542-43F	DPX-543	DPX-543-43F
No DC/AISG bypass	DPX-540	DPX-540-43F	DPX-541	DPX-541-43F

Electrical Characteristics		
1427-1496 MHz Channel (Low Band)		
Frequency Band	1427-1496 MHz	
Insertion Loss (typical)	< 0.25 dB	
Return Loss	> 18 dB	
Rejection (High Band)	50 dB	
Continuous Average Power	250 W	
Peak Power	2000 W	
Intermodulation, 2x43 dBm TX Carrier, IM3	-117 dBm	
1710-2170 MHz Channel (High Band)		
Frequency Band	1710-2170 MHz	
Insertion Loss (typical)	< 0.25 dB	
Return Loss	> 18 dB	
Rejection (Low Band)	50 dB	
Continuous Average Power	250 W	
Peak Power	2000 W	
Intermodulation, 2x43 dBm TX Carrier, IM3	-117 dBm	
General Electrical	Standard Models	Models with Auto-Sense
DC Bypass Rating	3 A	2 A, drop max 2.4 V
AISG Pass	Yes	---
AISG RL	---	> 12 dB
AISG Loss	---	< 1 dB
Lightning Protection	±5kA 8/20 µs	±5kA 8/20 µs
Input Voltage Power	---	8-30 V max 0.3 W

Quoted performance parameters are provided to offer typical or range values only and may vary as a result of normal manufacturing and operational conditions. Extreme operational conditions and/or stress on structural supports is beyond our control. Such conditions may result in damage to this product. Improvements to product may be made without notice.

DPX-54x

Diplexer | 1427-1496 MHz/1710-2170 MHz | Single and Twin Units | Indoor / Outdoor

Environmental			
Temperature Range		-40° to +65° C (-40° to 149° F)	
Ingress Protection		IP67	
Operation Compliance		ETS 300 019-1-4 Class 4.1E	
Storage Compliance		ETS 300 019-1-1 Class 1.2	
Mechanical Characteristics		Single Unit	Twin Unit
Finish		Light Grey, NCS 1502-R	
Connectors		7/16 Female or 4.3-10 Female	
Dimensions (H x W x D)	Standard Models	140 x 118 x 60 mm (5.5 x 4.7 x 2.4 in)	TBD
	Models with Auto-Sense	TBD	TBD
Weight (with Brackets)	Standard Models	≤ 2 kg (≤ 4.4 lbs)	TBD
	Models with Auto-Sense	TBD	TBD
Mounting Options		Description	
Pole / Wall Bracket		Two metal clamps for pole mount included; Pole Diameter 40-140 mm (1.57-5.5 in)	
Block Diagrams			
<p>DC/AISG Bypass High Band</p> <p>DPX-544 DPX-545</p>	<p>DC/AISG Bypass Low Band</p> <p>DPX-546 DPX-547</p>	<p>Full DC/AISG Bypass</p> <p>DPX-542 DPX-543</p>	<p>No DC/AISG Bypass</p> <p>DPX-540 DPX-541</p>

Quoted performance parameters are provided to offer typical or range values only and may vary as a result of normal manufacturing and operational conditions. Extreme operational conditions and/or stress on structural supports is beyond our control. Such conditions may result in damage to this product. Improvements to product may be made without notice.

DPX-54x

Diplexer | 1427-1496 MHz/1710-2170 MHz | Single and Twin Units | Indoor / Outdoor

Dimensions - Single Unit with 4.3-10 Connectors

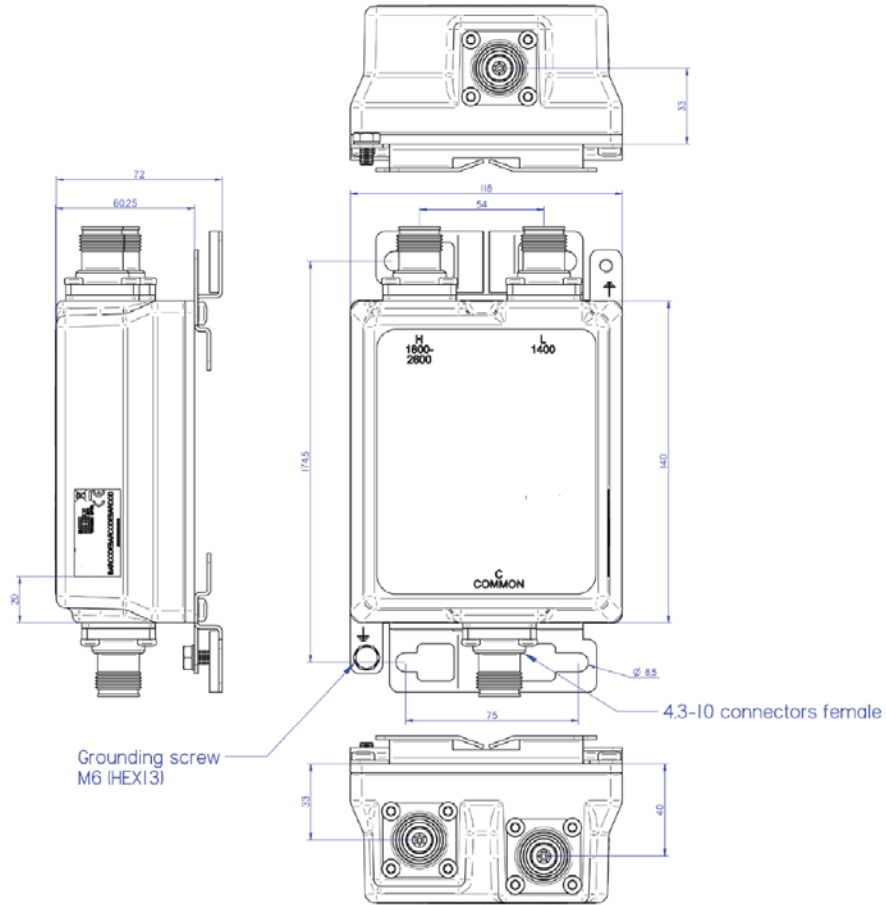

Quoted performance parameters are provided to offer typical or range values only and may vary as a result of normal manufacturing and operational conditions. Extreme operational conditions and/or stress on structural supports is beyond our control. Such conditions may result in damage to this product. Improvements to product may be made without notice.