



NetSure™

DC Distribution Panel

Installation and User Manual (Section 6029), Revision G

Specification Number: 545277

The information contained in this document is subject to change without notice and may not be suitable for all applications. While every precaution has been taken to ensure the accuracy and completeness of this document, Vertiv Group Corporation assumes no responsibility and disclaims all liability for damages resulting from use of this information or for any errors or omissions. Refer to other local practices or building codes as applicable for the correct methods, tools, and materials to be used in performing procedures not specifically described in this document.

This document may contain confidential and/or proprietary information of Vertiv Group Corporation, and its receipt or possession does not convey any right to reproduce, disclose its contents, or to manufacture or sell anything that it may describe. Reproduction, disclosure, or use without specific authorization from Vertiv Group Corporation is strictly prohibited.

Vertiv and the Vertiv logo are trademarks or registered trademarks of Vertiv Group Corporation. NetPerform™, NetReach™, NetSure™ and NetXtend™ are trademarks of Vertiv Energy Systems, Inc. All other trademarks are the property of their respective owners.

© 2017 Vertiv Energy Systems, Inc. All rights reserved.

TABLE OF CONTENTS

Admonishments Used in this Document	4
Important Safety Instructions	5
General Safety	5
DC Output and Battery Voltages	5
Description	7
Accessories	7
Bullet Nose Type Circuit Breakers	7
TPS/TLS-Type Fuses.....	8
Lug Adapter Busbar for 250 a Bullet Nose Type Circuit Breaker (Part No. 514717)	10
Lug Adapter Busbar for 125 A to 200 A Bullet Nose Type Circuit Breakers (Part No. 534449).....	10
Lug Adapter Busbar for 250 a Bullet Nose Type Circuit Breaker (Part No. 514714).....	11
Special Application Crimp Lug/Strap.....	11
Dimensions	12
Installer’s Connections	13
Input Connections	13
Load Connections.....	15
Circuit Breaker Alarm / Fuse Alarm Connections.....	15
Installing Distribution Devices.....	16

ADMONISHMENTS USED IN THIS DOCUMENT



DANGER! Warns of a hazard the reader *will* be exposed to that will *likely* result in death or serious injury if not avoided. (ANSI, OSHA)



WARNING! Warns of a potential hazard the reader *may* be exposed to that *could* result in death or serious injury if not avoided. This admonition is not used for situations that pose a risk only to equipment, software, data, or service. (ANSI)



CAUTION! Warns of a potential hazard the reader *may* be exposed to that *could* result in minor or moderate injury if not avoided. (ANSI, OSHA) This admonition is not used for situations that pose a risk only to equipment, data, or service, even if such use appears to be permitted in some of the applicable standards. (OSHA)



ALERT! Alerts the reader to an action that *must be avoided* in order to protect equipment, software, data, or service. (ISO)



ALERT! Alerts the reader to an action that *must be performed* in order to prevent equipment damage, software corruption, data loss, or service interruption. (ISO)



FIRE SAFETY! Informs the reader of fire safety information, reminders, precautions, or policies, or of the locations of fire-fighting and fire-safety equipment. (ISO)



SAFETY! Informs the reader of general safety information, reminders, precautions, or policies not related to a particular source of hazard or to fire safety. (ISO, ANSI, OSHA)

IMPORTANT SAFETY INSTRUCTIONS

General Safety



DANGER! YOU MUST FOLLOW APPROVED SAFETY PROCEDURES.

Performing the following procedures may expose you to hazards. These procedures should be performed by qualified technicians familiar with the hazards associated with this type of equipment. These hazards may include shock, energy, and/or burns. To avoid these hazards:

- a) The tasks should be performed in the order indicated.
- b) Remove watches, rings, and other metal objects.
- c) Prior to contacting any uninsulated surface or termination, use a voltmeter to verify that no voltage or the expected voltage is present. Check for voltage with both AC and DC voltmeters prior to making contact.
- d) Wear eye protection.
- e) Use certified and well maintained insulated tools. Use double insulated tools appropriately rated for the work to be performed.

DC Output and Battery Voltages



DANGER! This system produces DC power and may have a battery source connected to it. Although the DC voltage is not hazardously high, the rectifiers and/or battery can deliver large amounts of current. Exercise extreme caution not to inadvertently contact or have any tool inadvertently contact an output terminal or battery terminal or exposed wire connected to an output terminal or battery terminal. NEVER allow a metal object, such as a tool, to contact more than one termination or battery terminal at a time, or to simultaneously contact a termination or battery terminal and a grounded object. Even a momentary short circuit can cause sparking, explosion, and injury.



DANGER! Follow local lockout/tagout procedures to ensure DC branch circuit protection devices remain de-energized during installation at loads, as required.

This page is intentionally blank.

DESCRIPTION

Spec. No. 545277 is a DC Distribution assembly, which accepts up to twenty (20) separately ordered Bullet Nose-type circuit breakers or TPS/TLS type fuses in bullet nose fuseholders. The assembly is designed for mounting on a wall or in a 23" relay rack. See "Dimensions" on page 6 for mounting details. See **Table 3** and **Table 4** for a list of available circuit breakers and fuses. This assembly is designed for use in 24 VDC or 48 VDC systems. Maximum current rating is 600 amperes at 40°C, 300 amperes at 65°C and 250 amperes at 70°C.

This panel is UL Listed for use in DC Power Distribution Centers for Communications Equipment.



ALERT! When this panel is used in non-factory integrated systems, external branch circuit protection is required for all input feeds.

ACCESSORIES

Bullet Nose Type Circuit Breakers

See **Table 3** on page 9 for available circuit breakers.

Each circuit breaker plugs into a single mounting position (Exceptions: 125A, 150A and 200A occupy two mounting positions. 250A occupies three mounting positions).

Unless otherwise specified, breakers are to be mounted from right to left starting with the highest capacity and working to the lowest capacity.

See **Table 1** for circuit breaker restrictions.

Table 1: Bullet Nose Type Circuit Breaker Restrictions

Ambient Temperature	Min Rating (A)	Max Rating (A)	Max Allowed Load as Percentage of Device Rating	Device Rating Requiring Spacing Between it and Any Other Overcurrent Protective Device
40°C	1	250	80%	>150A
65°C	150	150	80%	150A
70°C	1	80	75%	>1A



ALERT! When used at 40°C, a circuit breaker with a rating greater than 150 amperes SHALL HAVE an empty mounting position between it and any other overcurrent protective device. Load should not exceed 80% of device rating.



ALERT! When used at 65°C, a circuit breaker rated at 150 amperes SHALL HAVE an empty mounting position between it and any other overcurrent protective device. Load should not exceed 80% of device rating.



ALERT! When used at 70°C, every circuit breaker SHALL HAVE an empty mounting position between it and any other overcurrent protective device. Load should not exceed 75% of device rating.

TPS/TLS-Type Fuses

See **Table 4** on page 10 for available fuses.

Each fuse requires fuseholder. A single fuseholder provides for installation of a 3 A to 100 A Bussmann TPS-type or Littelfuse TLS-type fuse. This fuseholder plugs into a single mounting position. Each fuseholder includes a GMT-A alarm type fuse, which operates open to provide an alarm indication if the distribution fuse opens.

Fuseholders are not furnished and must be ordered as required. Order (1) Part No. 117201 fuseholder for each fuse position required. Fuseholder includes (1) alarm fuse (Bussmann GMT-A 18/100 A; our Part Number 248610301) and (1) alarm fuse safety cover (our Part Number 248898700).

Unless otherwise specified, fuses are to be mounted from right to left starting with the highest capacity and working to the lowest capacity.

See **Table 2** for fuse restrictions.

Table 2: TPS/TLS-Type Fuse Restrictions

Ambient Temperature	Min Rating (A)	Max Rating (A)	Max Allowed Load as Percentage of Device Rating	Device Rating Requiring Spacing Between it and Any Other Overcurrent Protective Device
40°C	1	250	80%	>150A
65°C	150	150	80%	150A
70°C	1	80	75%	>1A



ALERT! When used at 40°C, load should not exceed 80% of device rating.



ALERT! When used at 65°C, every fuse SHALL HAVE an empty mounting position between it and any other overcurrent protective device. Load should not exceed 80% of device rating.



ALERT! When used at 70°C, every fuse SHALL HAVE an empty mounting position between it and any other overcurrent protective device. Load should not exceed 75% of device rating.

Table 3:

BULLET NOSE TYPE CIRCUIT BREAKERS		
AMPERE RATING	PART NUMBER Electrical/ Mechanical Trip1 (Black Handle)	PART NUMBER Electrical Trip2 (White Handle)
1	101596	102272
3	101597	102273
5	101598	102274
10	101599	102275
15	101600	102276
20	101601	102277
25	101602	102278
30	101603	102279
35	101604	102280
40	101605	102281
45	121997	121998
50	101606	102282
60	101607	102283
70	101608	102284
75	101609	102285
80	121995	121996
100	101610	102286
125	516838	516991
150	516839	516993
200 (see Alert below)	121832	121831
250 (see Alert below)	121836	121835
¹ These circuit breakers provide an alarm during an electrical or manual trip condition. ² These circuit breakers provide an alarm during an electrical trip condition only.		



ALERT! When used at 40°C, a circuit breaker with a rating greater than 150 amperes SHALL HAVE an empty mounting position between it and any other overcurrent protective device. Load should not exceed 80% of device rating.



ALERT! When used at 65°C, a circuit breaker rated at 150 amperes SHALL HAVE an empty mounting position between it and any other overcurrent protective device. Load should not exceed 80% of device rating.



ALERT! When used at 70°C, every circuit breaker SHALL HAVE an empty mounting position between it and any other overcurrent protective device. Load should not exceed 75% of device rating.

Table 4:

TPS/TLS TYPE FUSES			
AMPERE RATING	PART NUMBER	AMPERE RATING	PART NUMBER
3	248230900	40	248233300
5	248231000	50	248233900
6	248231200	60	248234200
10	248231500	70	248234500
15	248231800	80	118413
20	248232100	90	118414
25	248232400	100	118415
30	248232700		



ALERT! When used at 40°C, load should not exceed 80% of device rating.



ALERT! When used at 65°C, every fuse SHALL HAVE an empty mounting position between it and any other overcurrent protective device. Load should not exceed 80% of device rating.



ALERT! When used at 70°C, every fuse SHALL HAVE an empty mounting position between it and any other overcurrent protective device. Load should not exceed 75% of device rating.

Lug Adapter Busbar for 250 A Bullet Nose Type Circuit Breaker (Part No. 514717)

Provides strapping busbar for 250 A bullet nose circuit breaker load terminals. Allows use of Special Application Crimp Lug / Strap Combination, which accepts required wire size.

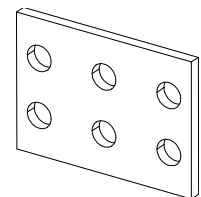

Order (1) Part No. 514717 per 250 A Bullet Nose circuit breaker ordered, as required.

Lug Adapter Busbar for 125 A to 200 A Bullet Nose Type Circuit Breakers (Part No. 534449)

Includes one (1) busbar that mounts on the two lug landing positions of a 125 A to 200 A bullet nose circuit breaker, and provides a landing for one standard two-hole lug having 3/8" bolt clearance holes on 1" centers. Also includes one (1) busbar that mounts on two landings of the system ground return bar, and provides one landing for a standard two-hole lug having 3/8" bolt clearance holes on 1" centers. All busbar and lug mounting hardware is included.

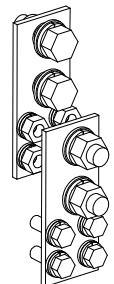

Order one (1) Part No. 534449 per 125 A to 200 A Bullet Nose circuit breaker ordered, as required.

Lug Adapter Busbar for 250 A Bullet Nose Type Circuit Breaker (Part No. 514714)

Includes one (1) busbar that mounts on the three lug landing positions of a 250 A bullet nose circuit breaker, and provides a landing for one standard two-hole lug having 3/8" bolt clearance holes on 1" centers. Also includes one (1) busbar that mounts on three landings of the system ground return bar, and provides one landing for a standard two-hole lug having 3/8" bolt clearance holes on 1" centers. All busbar and lug mounting hardware is included.

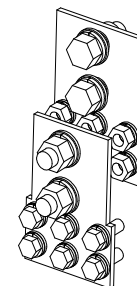

Order one (1) Part No. 514714 per 250 A Bullet Nose circuit breaker ordered, as required.

Special Application Crimp Lug/Strap

Straps two fuseholder/circuit breaker wiring positions together, and provides a crimp-type lug which allows distribution wiring up to 350 kcmil size. Designed for use with 125 A and larger bullet nose-type circuit breakers, which require at least two mounting positions. Specify part number as listed in **Table 5** for desired lead size.

NOTE! If used with bullet nose-type circuit breakers smaller than 125 A, an empty mounting position is required adjacent to the distribution device.

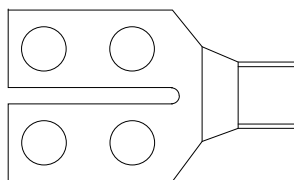

Table 5:

SPECIAL APPLICATION CRIMP LUG / STRAP (Two Hole Lug, 1/4" Bolt Clearance Hole, 5/8" Centers)					
LEAD SIZE	PART NUMBER		Crimp Tool Required ¹ , T&B Model TBM12 or TBM15 Hydraulic Heads		
			Color Key	Die Index/ Code No.	Die Cat. Number
1/0 AWG	245393500	Burndy: YA25L-4TCG1	PINK	42H	15508
2/0 AWG	245393600	Burndy: YA26L-4TCG1	BLACK	45	15526
3/0 AWG	245393700	Burndy: YA27L-4TCG1	ORANGE	50	15530
4/0 AWG	245393800	Burndy: YA28L-4TCG1	PURPLE	54H	15511
250 kcmil	514872	Burndy: YA29L-4TCG1	YELLOW	62	15510
		T&B: 256-30695-1879			
350 kcmil	514873	Burndy: YA31L-4TCG1	RED	71	15514
		T&B: 256-30695-1880			

¹ The lugs should be crimped to the specifications given in the manufacturer's instructions furnished with the crimp tool or lug.

DIMENSIONS

Figure 1:

NOTE:

1. ALL DIMENSIONS IN INCHES.
2. FINISH: OFF WHITE
3. WEIGHT (LBS.):

NET:
SHIPPING:

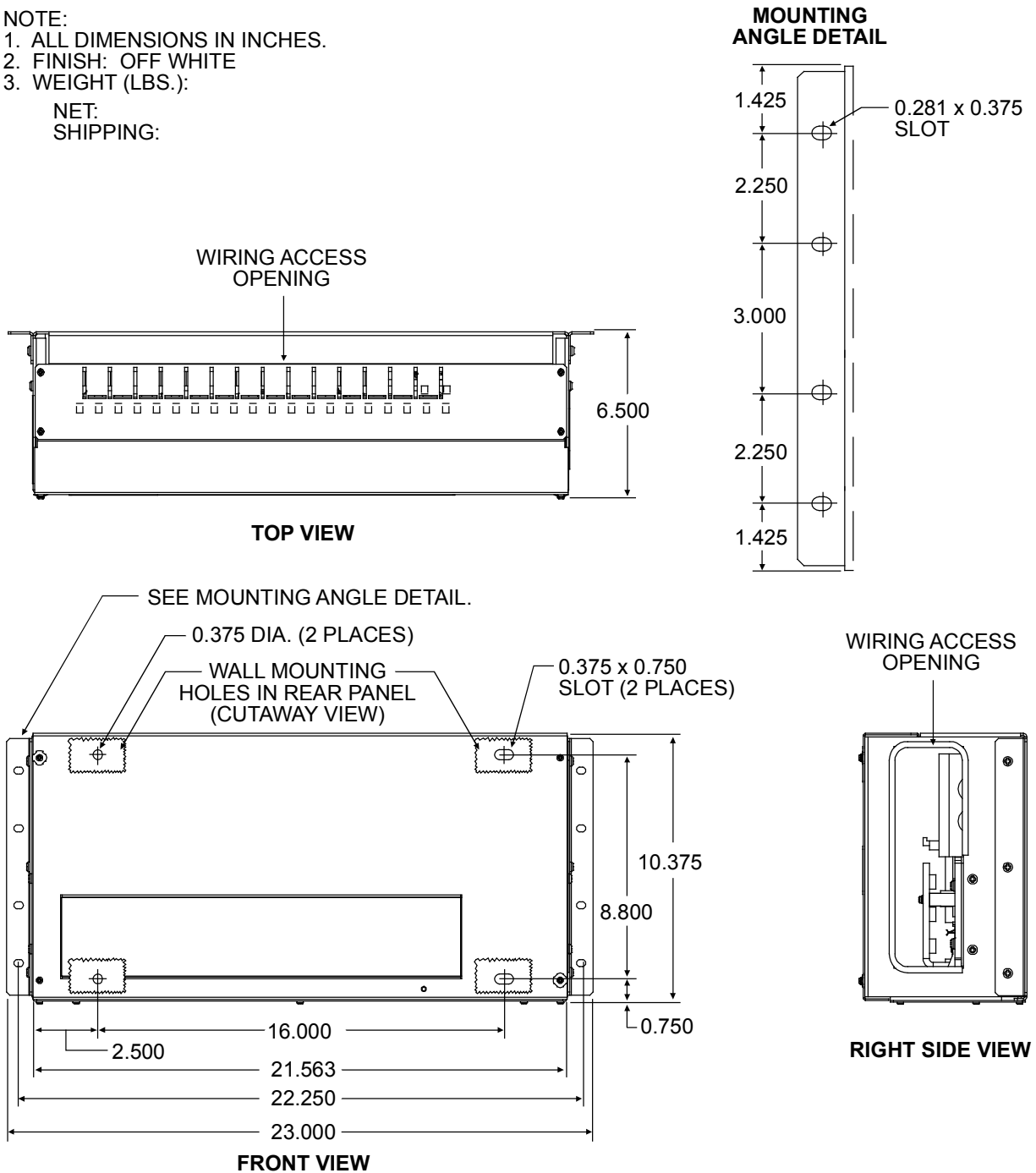

INSTALLER'S CONNECTIONS

See wiring diagram T545277 and schematic diagram SD545277 for all input, output, and alarm connections. Lugs must be supplied by the installer. Lug mounting hardware is furnished as standard. Refer to drawing 031110100 for additional lug information. Refer to **Figure 2** for busbar details.

Input Connections

Input wiring enters the assembly through the right-hand side panel. Recommended torque for 3/8-16 hardware is 180 in-lbs when using Belleville washers, and 300 in-lbs when using standard lock washers.

WARNING! When this panel is used in non-factory integrated systems, external branch circuit protection is required for all input feeds.

Recommended Input External Branch Circuit Protection, Wire Sizes, and Lugs

Input leads are connected to busbars located on the right side of the assembly. These busbars provide 3/8-16 threaded holes on 1" centers for installation of input leads terminated in two-hole lugs. Factory provides lug-mounting hardware.

- All lugs for customer connections must be ordered separately.
- DC input cable size varies depending on power requirements, therefore no specific information is provided for cable size. Refer to **Table 6** for recommended cable sizes and lugs at the rated maximum assembly load and other various loads. Note that loads typically should not exceed 80% of capacity; therefore, input cables have been sized for an overcurrent protection device rated at 125% of the expected load.
- For other available lugs and hardware, refer to drawings 031110100 through 031110300. Lugs should be crimped to the specifications given in the manufacturer's instructions furnished with the crimp tool or lugs.

Table 6: Recommended Input External Branch Circuit Protection, Wire Sizes, and Lug

External Overcurrent Protection Device Rating	Ambient Operating Temperature (1)	Loop Length (Ft) 1.0 Voltage Drop (2)	Recm 90°C Wire Size (1)	Recommended Crimp Lug (3)
750 A	40 °C	120.1	(2) 500 kcmil	245347800
600 A	40 °C	105.1	(2) 350 kcmil	245347700
500 A	40 °C	90.1	(2) 250 kcmil	245347500
400 A	40 °C	75.6	(2) 3/0 AWG	245347300
300 A	40 °C	63.4	(2) 1/0 AWG	245347100
200 A	40 °C	59.8	(2) 2 AWG	245348200
100 A	40 °C	29.7	(2) 8 AWG	245349800

- ¹ Wire sizes are based on recommendations of the American National Standards Institute (ANSI) approved National Fire Protection Association's (NFPA) National Electrical Code (NEC). Table 310-16 for copper wire rated at 90 °C conductor temperature operating in ambient temperatures of 40 °C was used. For other operating ambient temperatures, refer to the NEC. For operation in countries where the NEC is not recognized, follow applicable codes.
- ² Recommended wire sizes are sufficient to restrict maximum voltage drop to 1.0 volt at rated full load output current of the shelf for the loop lengths shown in this column. Loop length is the sum of the lengths of the positive and negative leads.
- ³ Two-hole lug, 3/8" bolt clearance hole, 1" centers. Refer to drawing 031110100 for lug crimping information.

Load Connections

Load and Load Return wiring enters the assembly through the top panel (through tabs on a plastic shield). Recommended torque for 1/4-20 hardware is 60 in-lbs when using Belleville washers, and 84 in-lbs when using standard lock washers.

Figure 2:

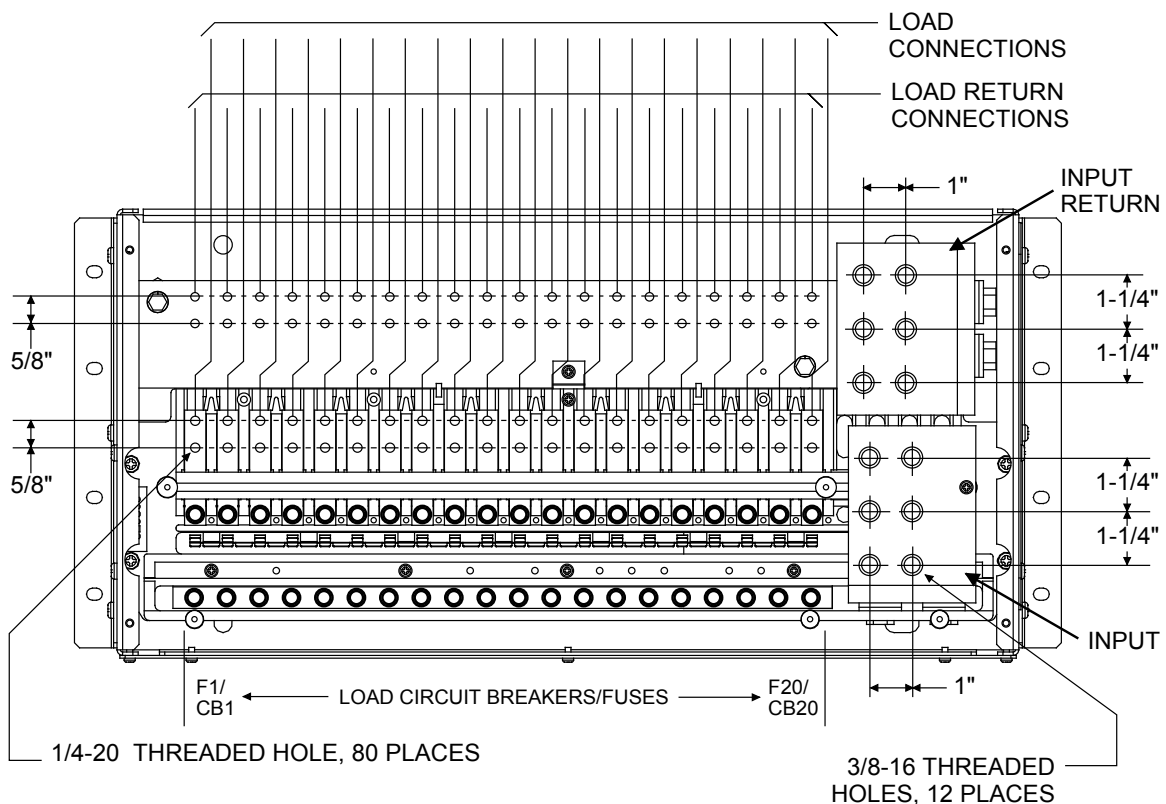

Circuit Breaker Alarm / Fuse Alarm Connections

Circuit Breaker Alarm / Fuse Alarm wiring enters the assembly through the right-hand side panel. Make alarm connections to terminal block J3 located on Alarm Circuit Card P/N 541183. Refer to **Figure 3** for location. Terminal block J3 accepts a wire size in the range of 26 AWG to 14 AWG. Recommended torque is 0.5 Nm to 0.6 Nm.

- If a circuit breaker or fuse in the assembly opens, relay contacts open between terminals 2 and 3 of J3 and relay contacts close between terminals 3 and 4 of J3. Normal operation provides close relay contacts between terminals 2 and 3 of J3 and open relay contacts between terminals 3 and 4 of J3.
- If a circuit breaker or fuse in the assembly opens, -48 V is provided at terminal 1 of J3.

Figure 3:

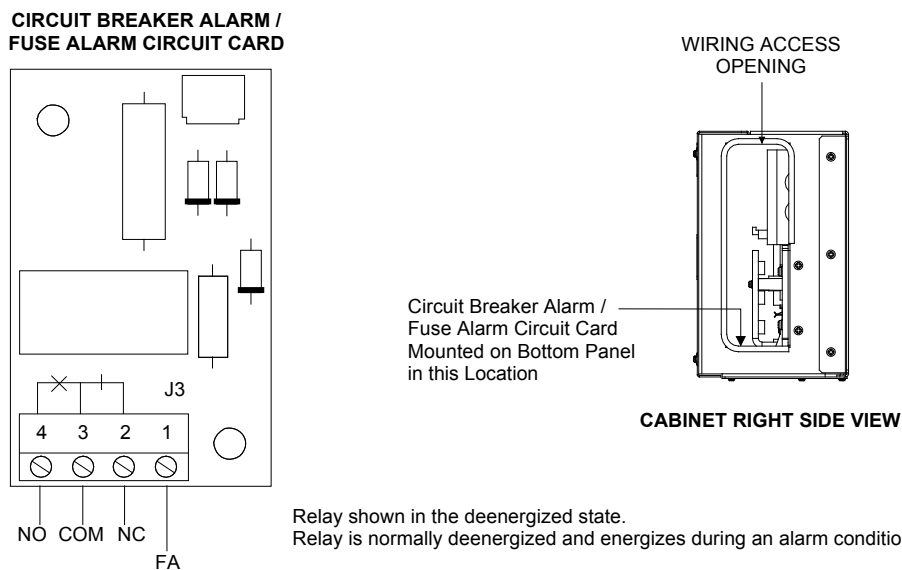

Installing Distribution Devices

Refer to **Figure 4** when installing distribution circuit breakers or fuses in the panel.

Inserts are furnished with the panel to install in any unused circuit breaker or fuseholder mounting positions.

Figure 4:

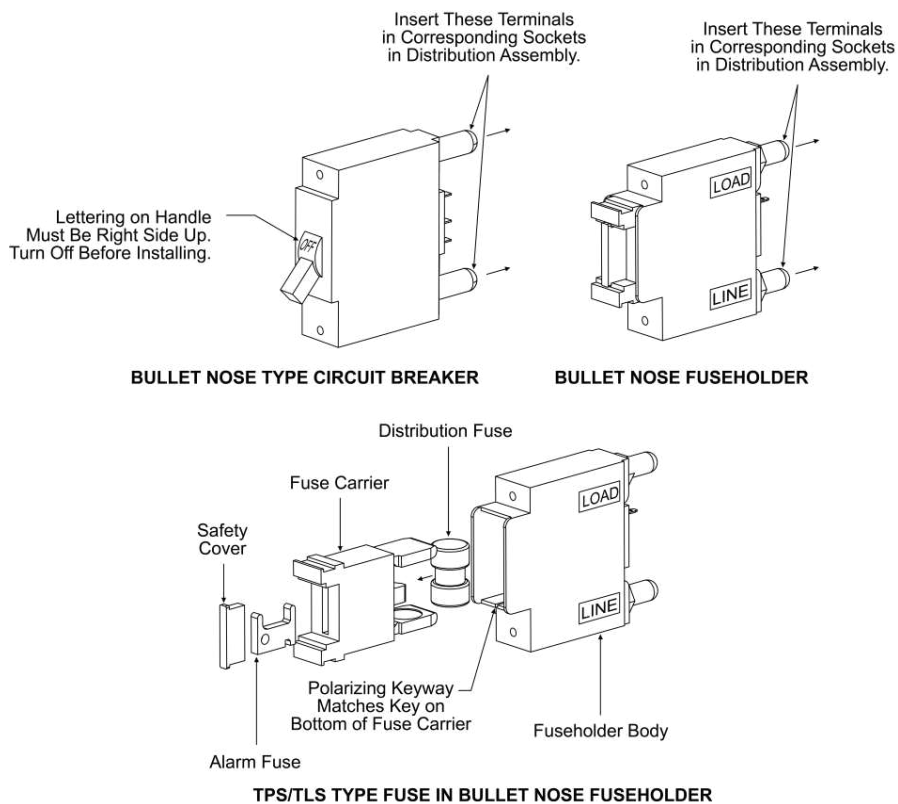

This Page Intentionally Blank.

