

4.4 ROU (Remote Optic Unit)

ROU receives TX optical signals from ODU or OEU and converts them into RF signals. The converted RF signals are amplified through High Power Amp in a corresponding RDU, combined with Multiplexer module and then radiated to the antenna port.

When receiving RX signals through the antenna port, this unit filters out-of-band signals in a corresponding RDU and sends the results to Remote Optic Module to make electronic-optical conversion of them. After converted, the signals are sent to a upper device of ODU or OEU. ROU can be equipped with up to three RDUs (Remote Drive Unit) and the module is composed of maximal Dual Band.

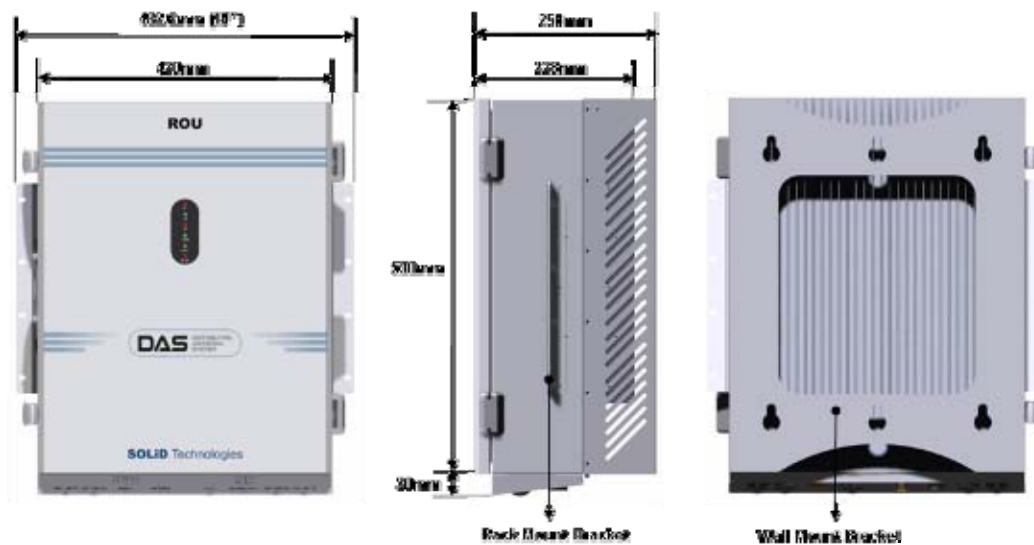

Figure 4.25 – ROU Outer Look

ROU is designed in a cabinet, and provides the following functions and features.

4.4.1 Specifications of ROU

Item	Spec.	Remark
Size(mm)	482.6(19") x 258 x560,	Including Bracket
Weight	35.45 Kg	Full Load
Power consumption	265 W	

4.4.2 Block Diagram of ROU

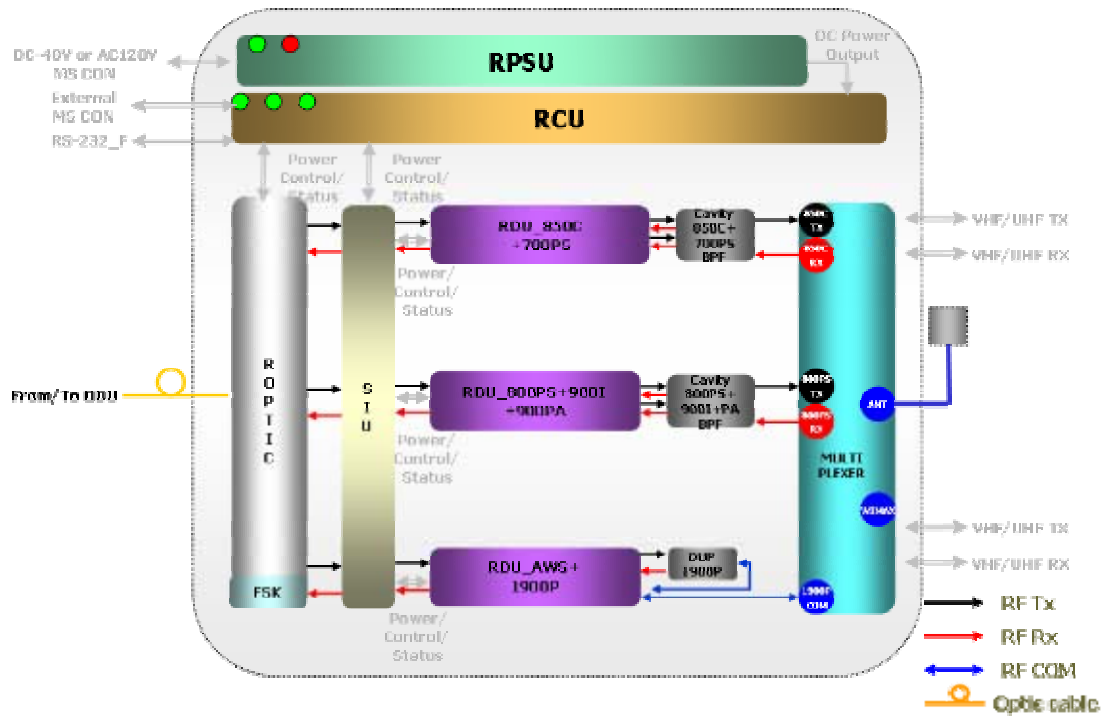

4.4.3 ROU parts

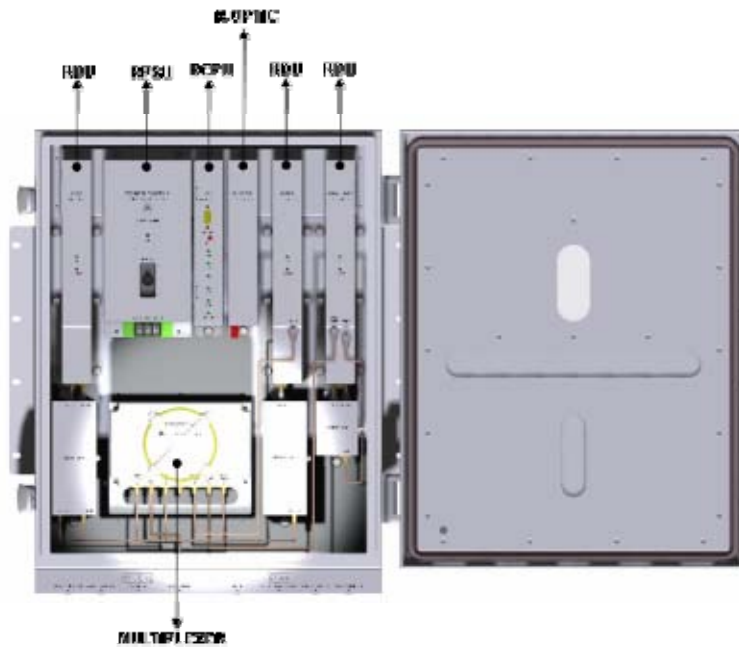

Figure 4.26 – ROU Inner Look

No.	Unit	Description	Remark
-----	------	-------------	--------

1	RDU+BPF	Remote Drive Unit Filter and high amplify TX signals; Filter and amplify RX signals; Remove other signals through BPF BPF is exclude from VHF+UHF module	
2	RPSU	Remote Power Supply Unit Input power: DC -48V, Output power: 27V,9V, 6V For 120V input of AC/DC; For -48V input of DC/DC	
3	R-OPTIC	Remote Optic Make RF conversion of TX optical signals; Convert RX RF signals into optical signals; Compensates optical loss Communicates with BIU/OEU though the FSK modem	
4	RCPU	Remote Central Processor Unit Controls signal of each unit Monitors BIU/ODU/OEU status through FSK modem communication	
5	Multiplexer	Multiplexer Combine TX signals from 3 RDUs; Distribute RX signals to 3 RDUs; Enable you to use a single antenna port	
6	Enclosure	Enclosure to satisfy NEMA4; Enable Wall/Rack Mount; Check if the system is normal, through the front panel LED	
7	SIU	System Interface Unit Distribute power and signals of each module	

4.4.4 Function by unit

1) Remote Drive Unit (RDU)

When receiving TX signals from each band through Remote Optic, RDU filters the signals and amplifies them with High Power Amplifier. The unit also filters RX signals given through Multiplexer and amplifies them to send the signals to Remote Optic.

In the unit, there is ATT to adjust gain. RDU devices are varied for each frequency band, including the following:

No	Unit naming	Description	BPF	
			TX	RX
1	RDU 800PS	Single,	External BPF	Internal BPF
2	RDU 850C	Single,	External BPF	External BPF
3	RDU 1900P+AWS-1	Dual,	External BPF(1900P) Internal BPF(AWS-1)	External BPF(1900P) Internal BPF(AWS-1)
4	RDU 800PS+900I+PA	Dual,	External BPF(800PS) Internal BPF(900I+PA)	Internal BPF(800PS) External BPF(900I+PA)
5	RDU 850C+700PS	Dual,	External BPF(850C) Internal BPF(700PS)	External BPF(850C) Internal BPF(700PS)
6	RDU VHF+UHF	Dual	External BPF(VHF,UHF)	External BPF(VHF,UHF)
7	RDU 850C+700LTEC	Dual,	External BPF(850C) Internal BPF(700LTEC)	External BPF(850C) Internal BPF(LTEC)

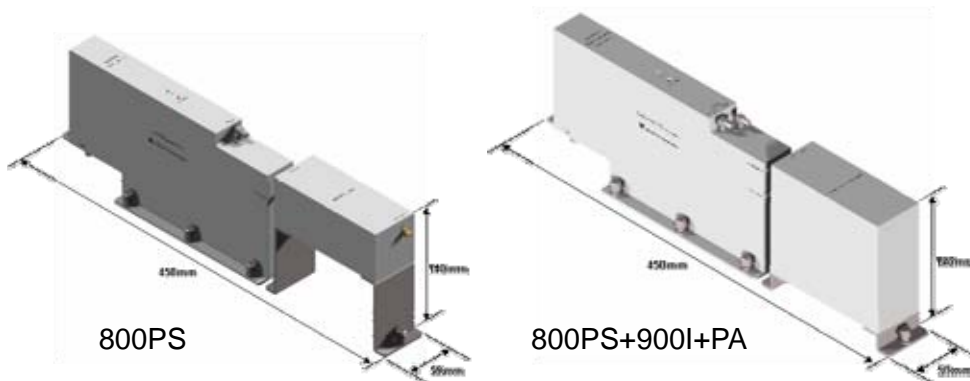

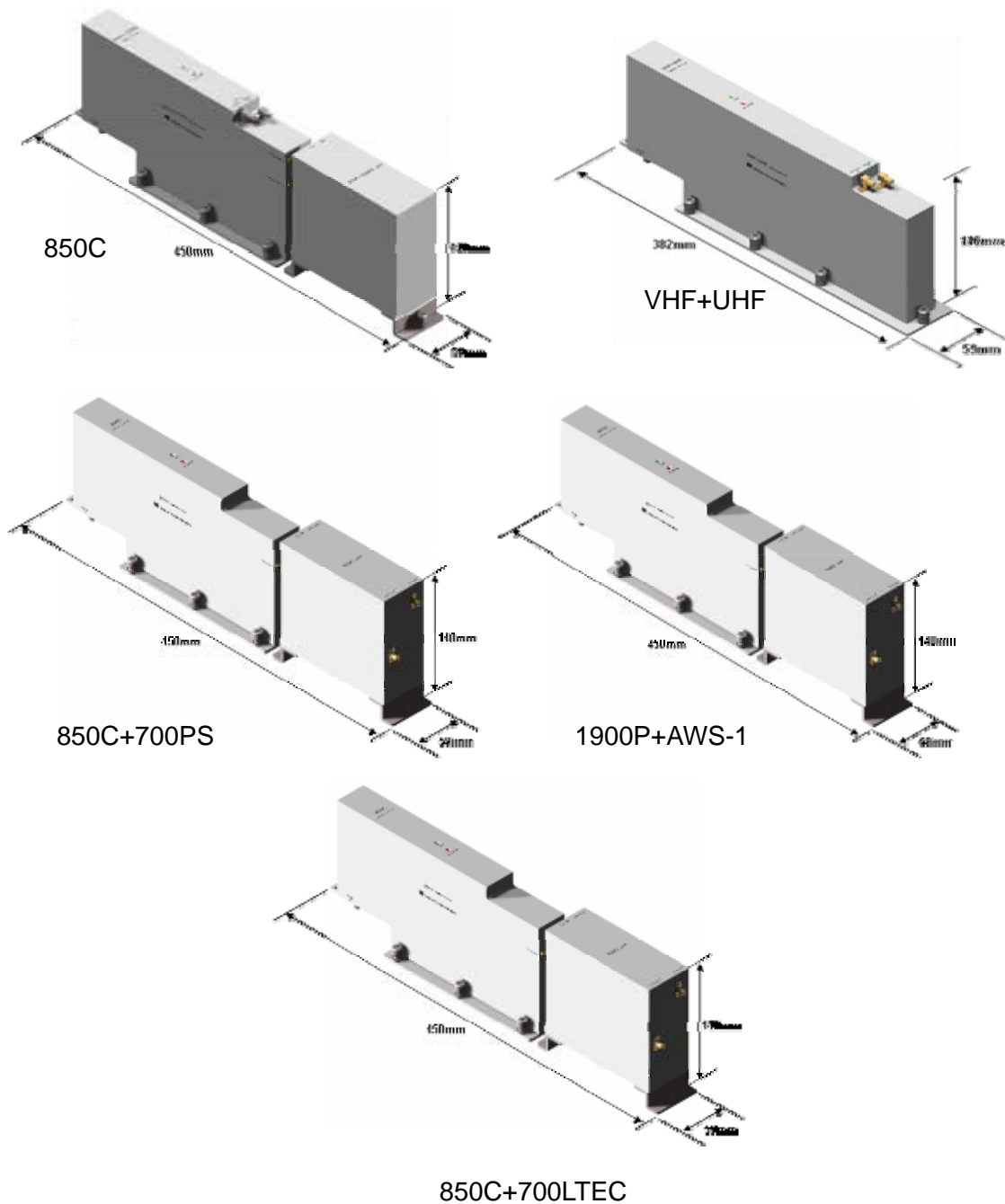

Figure 4.27 – RDU Outer Look

2) Remote Power Supply Unit (RPSU)

RPSU receives -48V of input. This unit is divided into DC/DC type to output +6V, +9V and +27V of DC power and AC/DC type to receive 120V of AC input and to output +6V, +9V and +27V of DC power.

Upon order, either of the two types should be decided. MS Connector, which uses ports to

receive inputs, is designed to accept any of AC and DC. Only in this case, the input cable is different.

RPSU has a circuit brake to turn the power ON/OFF and has LED indicator at the top to check if input power is normally supplied.

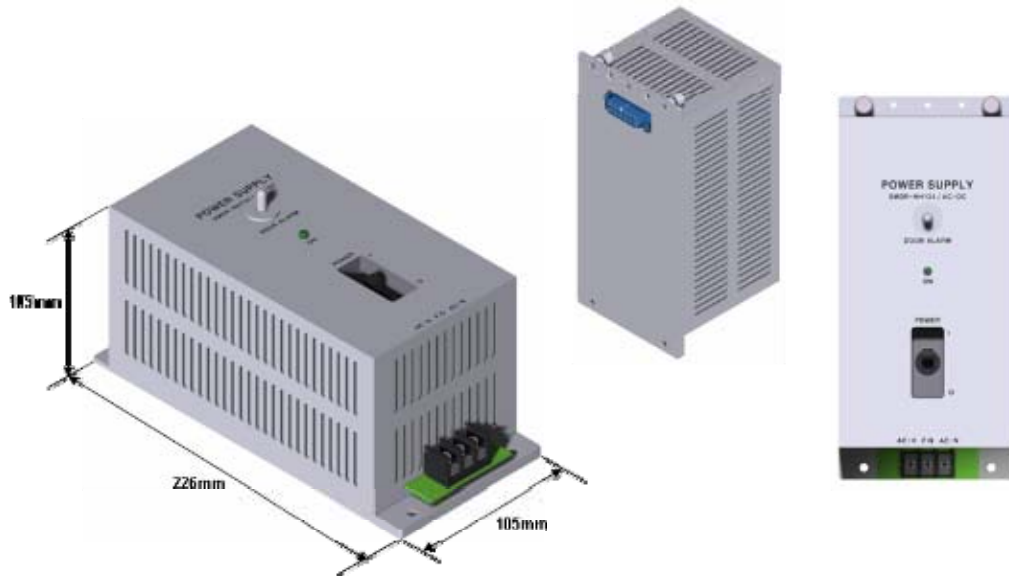

3) Remote Optic(R OPTIC)

Remote Optic converts optical signals into RF signals and performs vice versa. With an FSK modem in it, the unit communicates with upper devices.

It also has internal ATT for optical compensation to compensate for optical cable loss, if any.

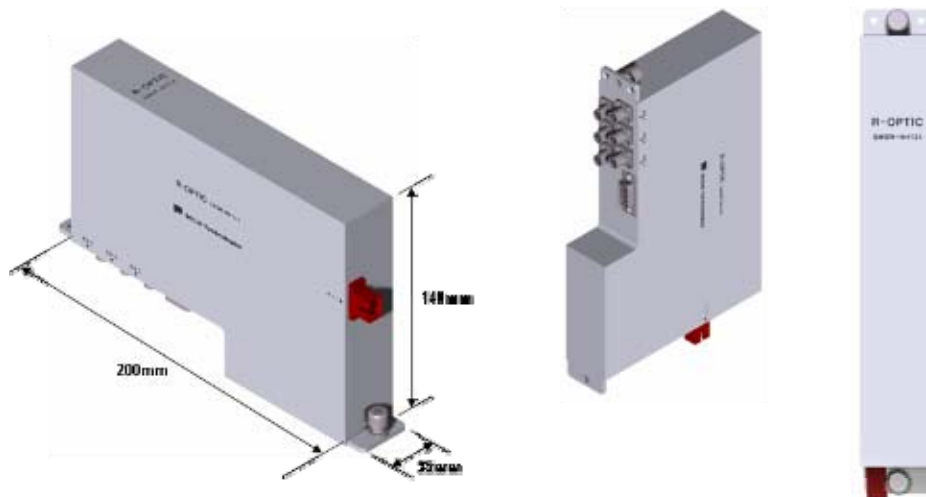

Figure 4.28 – R OPTIC Outer Look

4) Remote Central Processor Unit (RCPU)

RCPU can monitor and control each module of ROU. This unit receives and analyzes upper

communication data from Remote Optic and reports the unit's own value to upper devices. At the front of the module, it has LED indicator to show system status, letting you check any abnormalities at a time. At the same front, it also has communication LED Indicators to show communication status with upper devices. Through RS-232C Serial Port, the unit enables you to check and control device status through PC and laptop. This equipment is indoor use and all the communication wirings are limited to inside of the building.

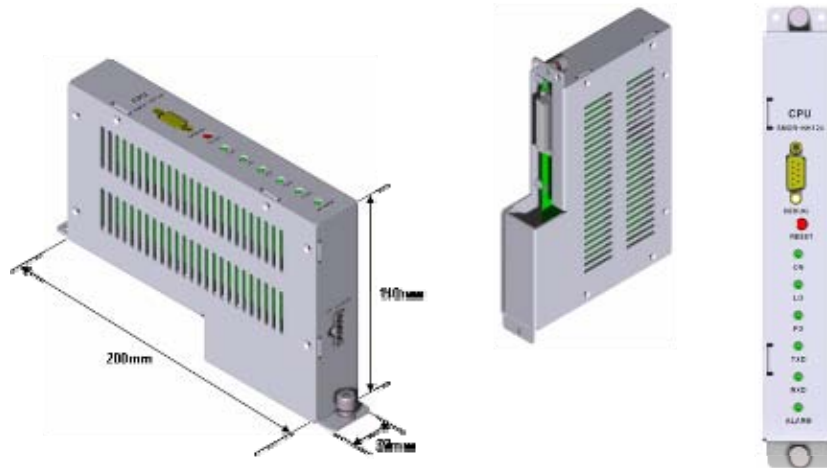

Figure 4.29 – RCPU Outer Look

5) Multiplexer

Multiplexer works as a module to combine or distribute multiple signals into one antenna. This device has a port to combine multiple signals. You need to connect input and output ports of RDU through a corresponding port.

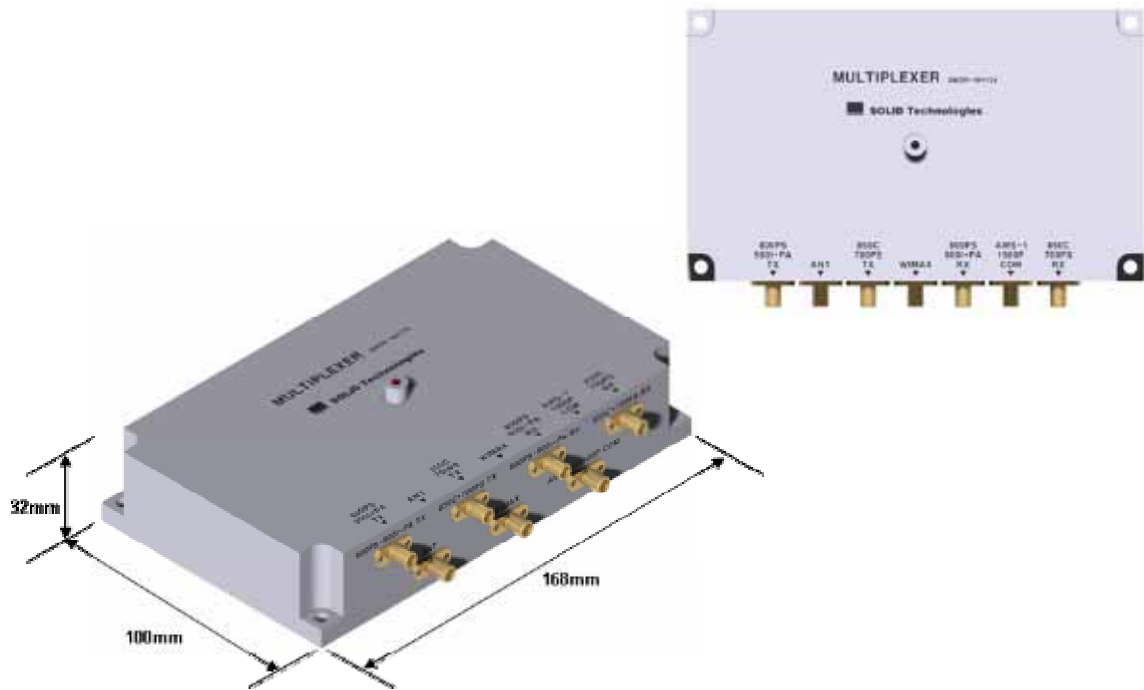

Figure 4.30 – Multiplexer Outer Look

6) System Interface Unit(SIU)

SIU distributes power and signals to each module.



4.4.5 Bottom of ROU

1) Functions

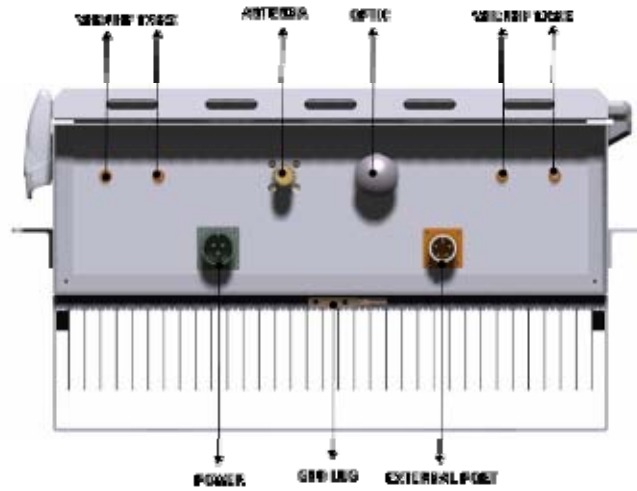

Figure 4.31 – ROU Bottom Look

Item	Description	Remark
1. VHF/UHF TX/RX Port	Terminal for TX and RX antenna ports of VHF and UHF	
2. Antenna Port	System Antenna Port, N-type female	
3. Power Port	AC 120V input port or DC-48V input port	
4. Optic Port	Optical input port	
5. External Port	Port for external devices	
6. GND LUG PORT	Terminal for system ground	

POWER PORT

Power ports are used for power-supplying of -48V DC or 120V AC, and specific power cable should be applied to each different types of ROU power supply (AC/DC or DC/DC). Below figure is naming of the power supply by type.



External PORT

External ports are reserved ports for external equipments for future implementation, and used to monitor the status and control the equipments.

Below figure is naming of the external ports.

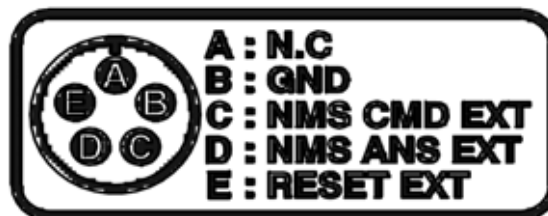

4.5 Add on V/UHF ROU

Add on V/UHF ROU(forward naming“AOR”) is connected existing ROU to service VHF and UHF band. AOR should support VHF+UHF RDU only, not support other RDUs which have cavity filter. RDUs which have cavity filter is too big so that AOR body can’t accommodate these.

AOR locates above or under of existing ROU. AOR receives TX signals from ROU and then amplify these through High Power Amplifier, filter out of band signals and radiated to the TX antenna port. When receiving RX signals through the RX antenna port, this unit filters out-of-band signals and amplify with Low noise Amlifier and output power is connected existing ROU’s RX port. External BPF should be located between TX/RX antenna and AOR’s IN/OUT ports because the BPF rejects the strong broadcasting signal and etc

AOR body meets to NEMA4 degree.

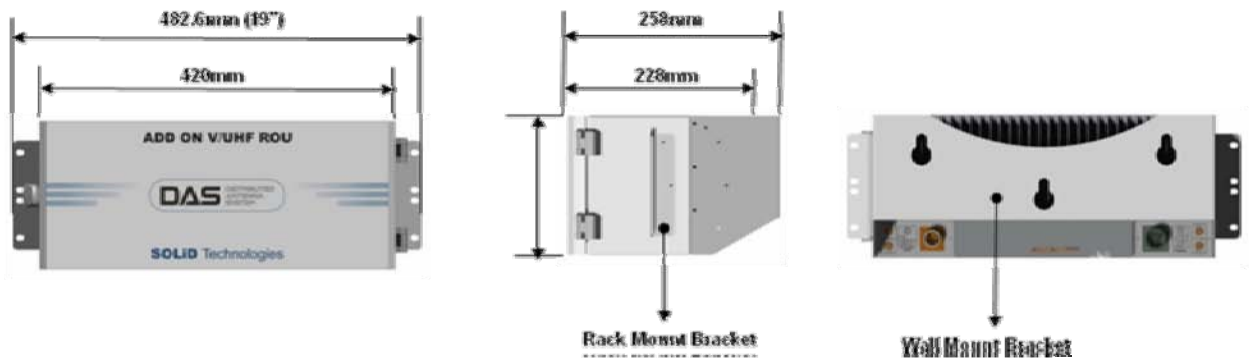

Figure 4.32 – AOR Outer Looks

AOR is designed in a cabinet, and provides the following functions and features.

4.5.1 Specifications of AOR

Item	Spec.	Remark
Size(mm)	482.6(19”) x 258 x177,	Including Bracket
Weight	11 Kg	
Power consumption	78 W	

4.5.2 Block Diagram of AOR

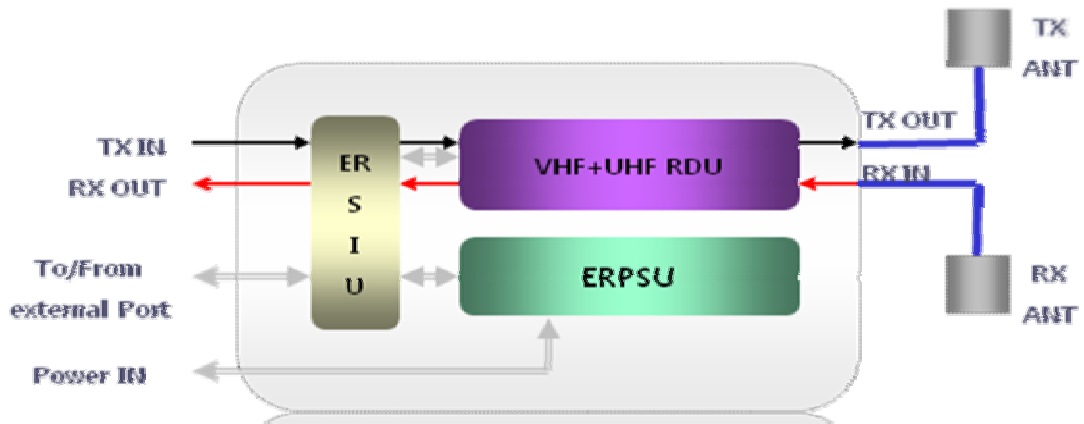

4.5.3 AOR parts

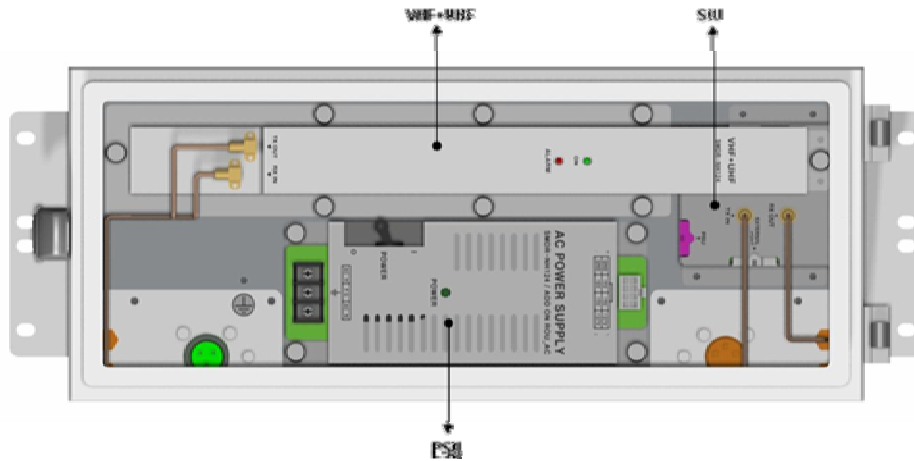

Figure 4.33 – AOR Inner Look

No.	Unit	Description	Remark
1	VHF+UHF RDU	VHF+UHF Remote Drive Unit Filter and high amplify TX signals; Filter and amplify RX signals; Remove other signals through internal BPF	

2	AOR PSU	AOR Power Supply Unit Input power: DC -48V, Output power: 27V,9V, 6V For 110V input of AC/DC; For -48V input of DC/DC	
3	Enclosure	Enclosure to satisfy NEMA4; Enable both Wall and Rack Mount;	
4	SIU	System Interface Unit Distribute power and signals of module	

4.5.4 Function by unit

1) VHF+UHF Remote Drive Unit (RDU)

When receiving TX signals from each band through existing ROU's Remote Optic, RDU filters out of band signals and amplifies them with High Power Amplifier. The unit also filters RX signals given through RX antenna and amplifies them to send the signals to existing ROU's Remote Optic.

In the unit, there is ATT to adjust gain each path. VHF+UHF RDU is not supported with cavity filter together. External BPF should be connected before antenna

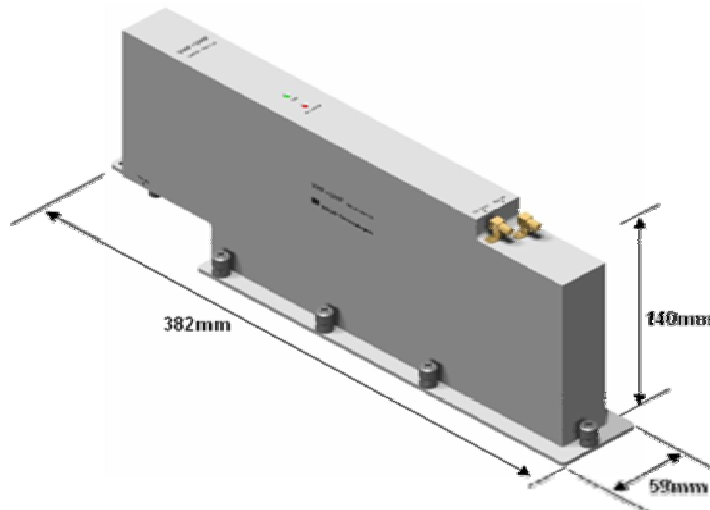

Figure 4.34 – RDU Outer Look

2) AOR Power Supply Unit (AOR PSU)

AOR PSU receives -48V of input. This unit is divided into DC/DC type to output +6V, +9V and +27V of DC power and AC/DC type to receive 110V of AC input and to output +6V, +9V and

+27V of DC power.

Upon your order, either of the two types should be decided. MS Connector, which uses ports to receive inputs, is designed to accept any of AC and DC. Only in this case, the input cable is different.

RPSU has a circuit brake to turn the power ON/OFF and has LED indicator at the top to check if output power is normally supplied.

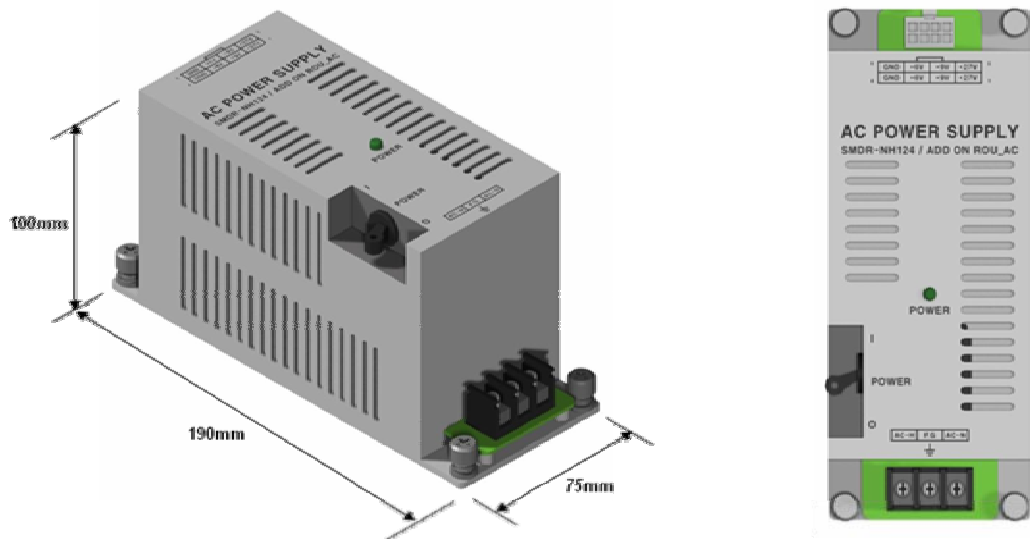

3) AOR System Interface Unit(SIU)

SIU distributes power and signals to each module.

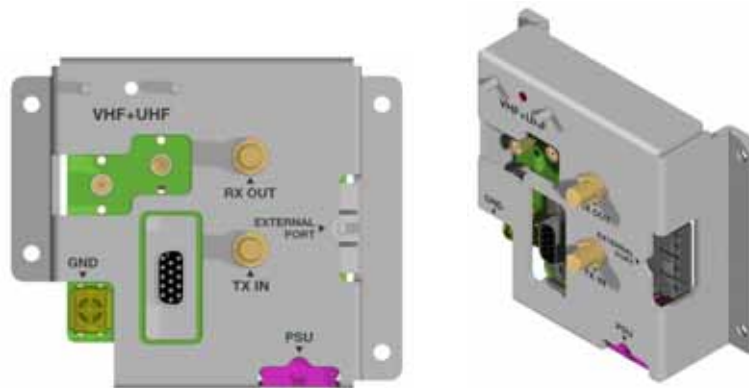

4.5.5 Rear of AOR

1) Functions

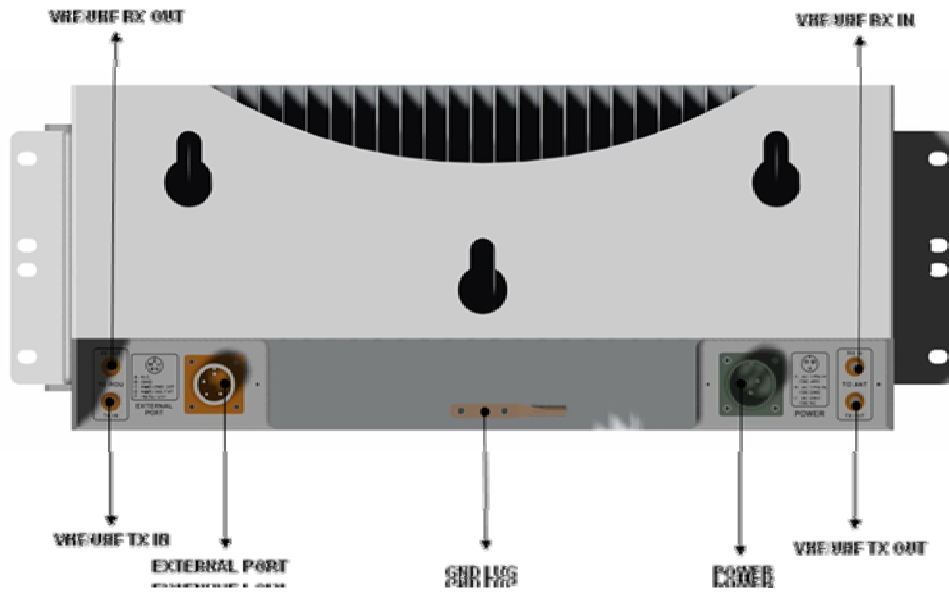

Figure 4.35 – AOR Rear Look

Item	Description	Remark
1. VHF/UHF TX IN	Terminal for receive the signal of TX from existing ROU	To/From Existing ROU
2. VHF/UHF RX OUT	Terminal for transmit the signal of RX to existing ROU	
3. Power Port	Terminal for input either AC 110V or DC-48V as internal PSU type	
4. VHF/UHF TX IN	Terminal for radiate the signal of TX to TX Antenna	To/From Antenna
5. VHF/UHF RX OUT	Terminal for receive the signal of RX from RX Antenna	
5.External Port	Port for communicate with existing ROU	
6.GND LUG PORT	Terminal for system ground	

POWER PORT

Power ports are used for power-supplying of -48V DC or 120V AC, and specific power cable should be applied to each different types of ROU power supply (AC/DC or DC/DC). Below figure is naming of the power supply by type.



External PORT

External ports are reserved ports for external equipments for future implementation, and used to monitor the status and control the equipments.

Below figure is naming of the external ports.

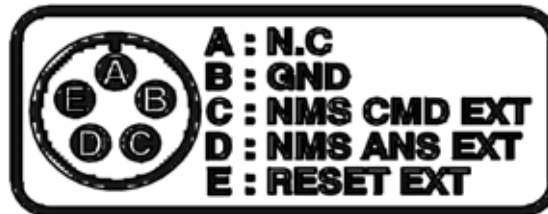

Section 5

System Installation & Operation

- 5.1 BIU Installation**
- 5.2 ODU Installation**
- 5.3 ROU Installation**
- 5.4 OEU Installation**
- 5.5 System Operation and Alarm Status**
- 5.6 Add on V/UHF ROU Installation**

This chapter describes how to install each unit and optical cables, along with power cabling method.

In detail, the chapter describes how to install shelves or enclosures of each unit, Power Cabling method and Optic Cabling and RF Interface. Furthermore, by showing power consumption of modules to be installed in each unit, it presents Power Cabling budget in a simple way. Then, it describes the quantity of components of modules to be installed in each unit and expansion method.

5.1 BIU Installation

5.1.1 BIU Shelf Installation

Generally, BIU is inserted into a 19" Standard Rack. As this unit has handles at each side for easy move. With two fixing holes at each side, you can tightly fix the unit into a 19" rack.

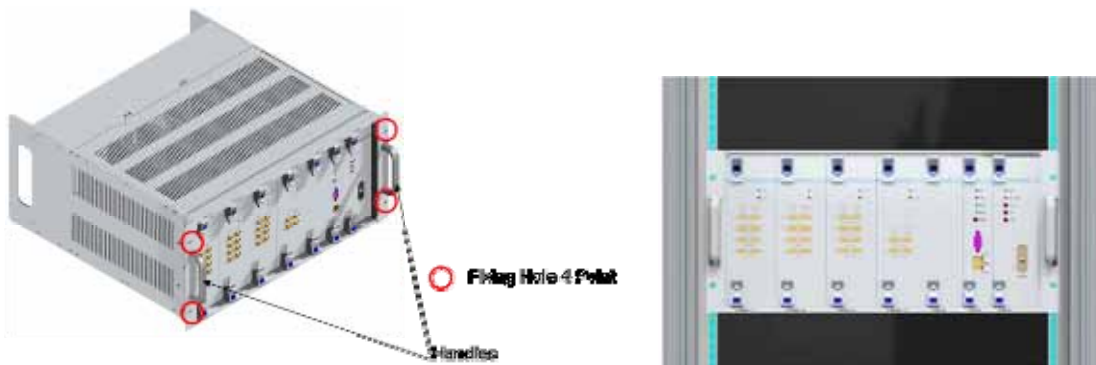

Figure 5.1 – RACK Installation

BIU has the following components:

No.	Unit	Description	Remark
Common Part	Shelf	Including Main Board, 19",5U	1EA
	MCDU	-	1EA
	MCPU	With Ethernet Port and RS-232 Port	1EA
	MPSU	Operate -48Vdc Input	1EA
	Power Cable	-48Vdc Input with two lug terminal	1EA
Optional Part	MDBU	800PS,800PS+900I+Paging,850C,850C+700P S, 1900P, AWS-1 MDBU	Up to 4EA to be inserted

Basically, the common part of BIU should have shelves and it should be equipped with MCDU to combine and divide TX/RX signals, MPSU to supply devices with power, MCDU to inquire and control state of each module and Power Cable to supply power from external rectifiers. In addition, MDBU can be inserted and removed to provide services for desired band (Optional).

5.1.2 BIU Power Cabling

BIU has -48V of input power. This unit should connect DC cable with the Terminal Block seen at the rear of BIU.

Terminal	Color of cable	Description	Remark
-48V	Blue color	-	
GND	Black color	-	
NC	Not Connected	-	

Before connecting the power terminal, you need to connect "+" terminal of Multi Voltage Meter probe with the GND terminal and then connect "-" terminal with -48V to see if "-48Vdc" voltage is measured. After the check, you need to connect the power terminal with the terminal of the terminal block seen below.

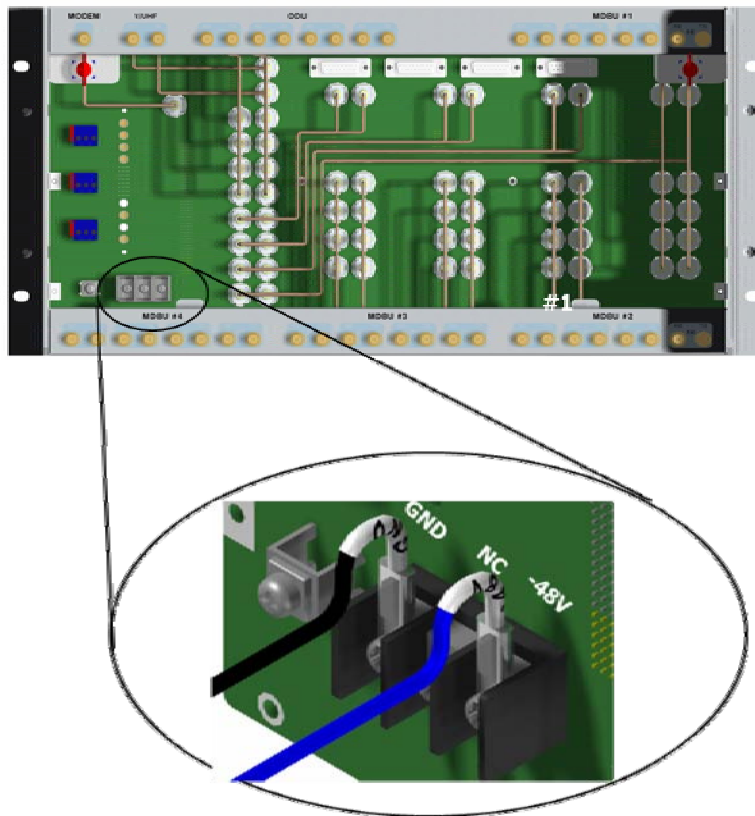



Note that BIU does not operate if the "+" terminal and the "-" terminal of the -48V power are not inserted into the accurate polarity.

When you connect -48V power with BIU, use the ON/OFF switch of MPSU located at the front of BIU to check the power.

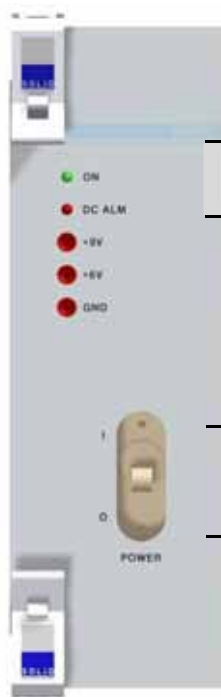

Power Switch	LED		Description
O	ON	●	Abnormal, Not supply Power -48Vdc
		●	Normal supply power -48Vdc
	DC ALM	●	Normal Status
		●	Failure of output Power
I	ON	●	Normal Status
	DC ALM	●	

5.1.3 RF Interface at BIU

BIU can be connected with Bi-Directional Amplifier and Base Station Tranceiver.

To connect BIU with BDA, you need to use a duplexer or a circulator to separate TX/RX signals from each other.

BIU can feed external TX/RX signals from the Back Plane.

Using MDBU separated from each carrier band, BIU can easily expand and interface with bands. As seen in the table below, MDBU is divided into Single and Dual Bands. The unit can be connected with two to four carrier signals per band. At the rear, #1~4 marks are seen in order per MDBU. The following table shows signals to be fed to corresponding ports:

No	Unit naming	Description		In/out RF Port	
				TX	RX
1	800PS MDBU	Single Band	Port #1	800PS TX(851~869MHz)	800PS RX(806~824MHz)
			Port#2	800PS TX(851~869MHz)	800PS RX(806~824MHz)
2	850C MDBU	Single Band	Port #3	850C TX(869~894MHz)	850C RX(824~849MHz)
			Port#4	850C TX(869~894MHz)	850C RX(824~849MHz)
3	1900P MDBU	Single Band	Port#1	1900P TX(1930~1995MHz)	1900P RX(1850~1915MHz)
			Port#2	1900P TX(1930~1995MHz)	1900P RX(1850~1915MHz)
			Port#3	1900P TX(1930~1995MHz)	1900P RX(1850~1915MHz)
			Port#4	1900P TX(1930~1995MHz)	1900P RX(1850~1915MHz)
4	AWS-1 MDBU	Single Band	Port#1	AWS-1 TX(2110~2155MHz)	AWS-1 RX(1710~1755MHz)

			Port#2	AWS-1 TX(2110~2155MHz)	AWS-1 RX(1710~1755MHz)
			Port#3	AWS-1 TX(2110~2155MHz)	AWS-1 RX(1710~1755MHz)
			Port#4	AWS-1 TX(2110~2155MHz)	AWS-1 RX(1710~1755MHz)
5	800PS+900I+PA MDBU	Dual Band 800PS:2Port 900I:1Port Paging:1Port	Port#1	800PS TX(851~869MHz)	800PS RX(806~869MHz)
			Port#2	800PS TX(851~869MHz)	800PS RX(806~869MHz)
			Port#3	Paging TX(929~932MHz)	Paging RX(896~902MHz)
			Port#4	900I TX(929~941MHz)	900I RX(896~902MHz)
6	850C+700PS MDBU	Dual Band 700PS:2Port 850C:2Port	Port#1	700PS TX(764~776MHz)	700PS RX(794~806MHz)
			Port#2	700PS TX(764~776MHz)	700PS RX(794~806MHz)
			Port#3	850C TX(869~894MHz)	850C RX(824~849MHz)
			Port#4	850C TX(869~894MHz)	850C RX(824~849MHz)
7	VHF+UHF MCDU	Dual Band VHF+UHF : 1Port	Port#1	VHF Tx(136~174MHz)	VHF Rx(136~174MHz)
				UHF Tx(396~512MHz)	UHF Tx(396~512MHz)
8	850C+700LTEC MDBU	Dual Band 700LTEC:2Port 850C:2Port	Port#1	700LTEC TX(746~756MHz)	700LTEC RX(777~787MHz)
			Port#2	700LTEC TX(746~756MHz)	700LTEC RX(777~787MHz)
			Port#3	850C TX(869~894MHz)	850C RX(824~849MHz)
			Port#4	850C TX(869~894MHz)	850C RX(824~849MHz)

At the rear of BIU, input and output ports are seen for each MDBU. The name of all the ports are silk printed as "#1, #2, #3 and #4." Referring to the table above, you need to feed right signals to input and output ports of corresponding MDBU.

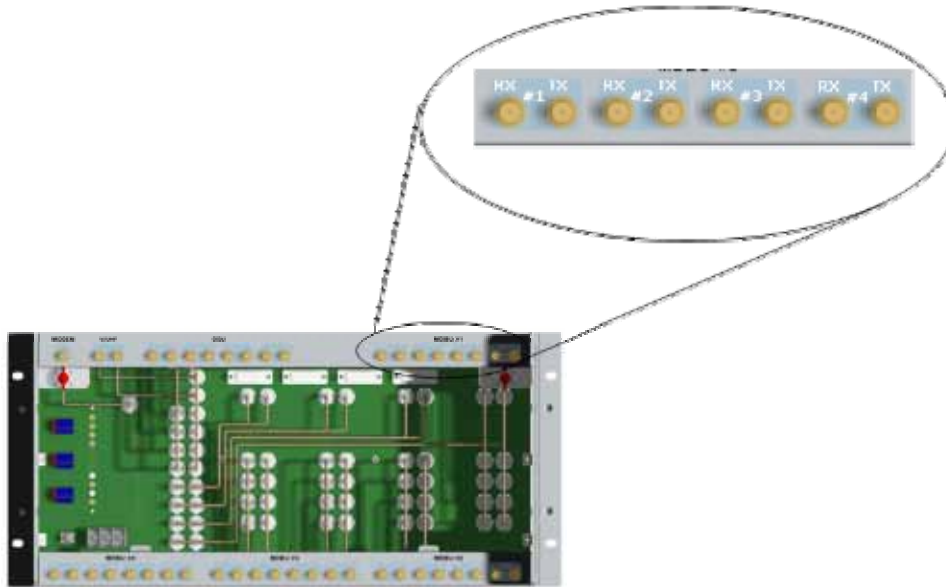

For each port, TX signals and RX signals are separated from each other. You don't have to terminate unused ports unless you want to.

BIU interface with Base station Transceiver

Basically, BIU has different TX and RX ports, and so, you have only to connect input and output ports.

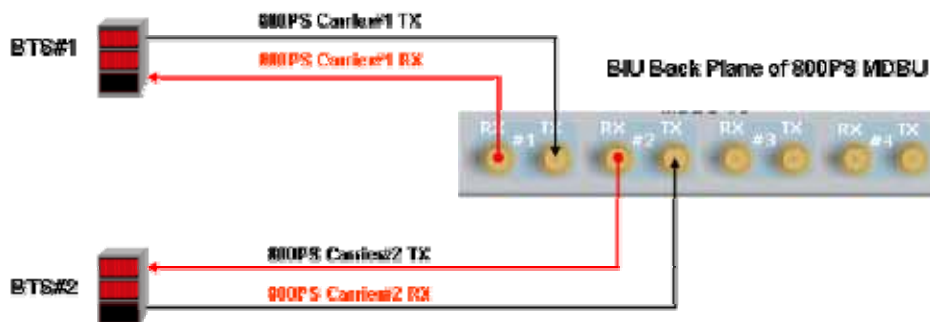

Through spectrum, you need to check signals sent from BTS TX. If the signals exceed input range (-20dBm~+10dBm), you can connect an attenuator ahead of the input port to put the signals in the input range.

BIU interface with Bi-Directional Amplifier

Basically, BIU is in Simplexer type; when you use BDA, you need to separate BDA signals from TX and RX type.

Using a duplexer or a circulator, you can separate TX/RX signals of an external device

from each other.

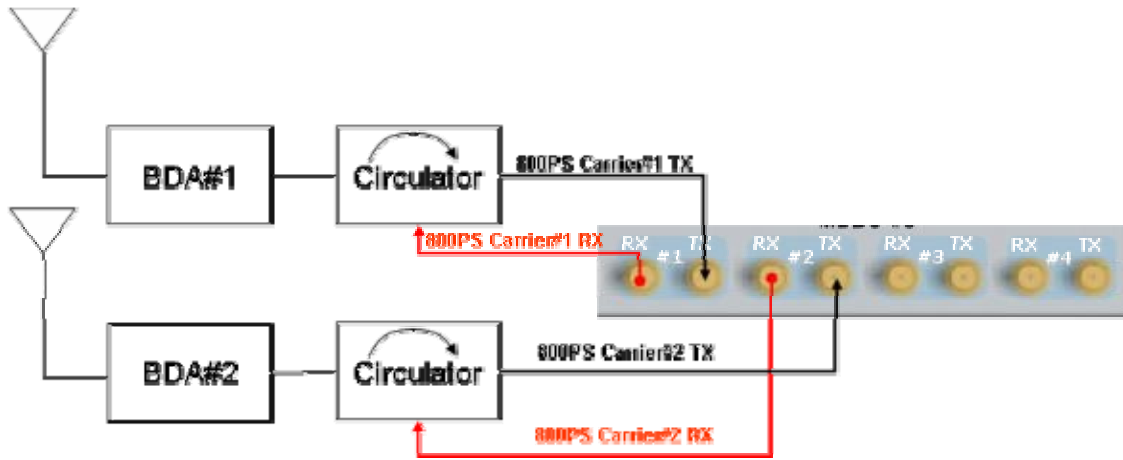

Figure 5.2 – 800PS BDA Interface using Circulator

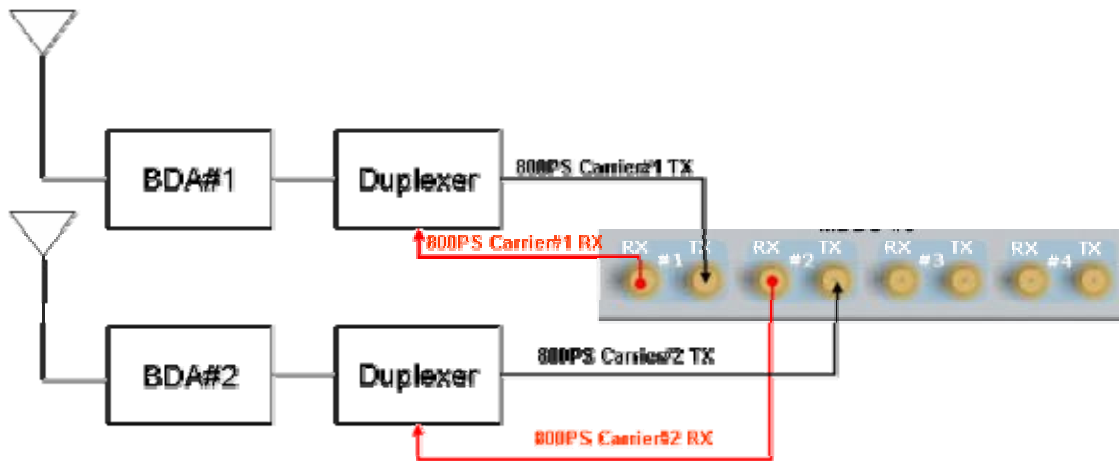

Figure 5.3 – 800PS BDA Interface using Duplexer

BIU interfaces with BDA in either of the methods above. In this case, you need to check TX input range as well.



Given the TX input range (-20dBm~+10dBm/Total per port), make sure to see if the value is in the input range, using Spectrum Analyzer, when you connect input ports.

5.1.4 MDBU insertion

MDBU is designed to let a MDBU be inserted into any slot.

BIU can be equipped with a total of four MDBUs. If only one MDBU is inserted into a slot with the other slots reserved, you need to insert BLANK cards into the other slots.



If you do not terminate input and output ports of MCDU, which combines TX signals and divides RX signals, it will cause loss and generation of spurious signals at the other party's band. Given this, make sure to insert MDBU BLANK into slots of MDBU.

When MDBU is inserted into BIU, LED at the front panel will show the following information:

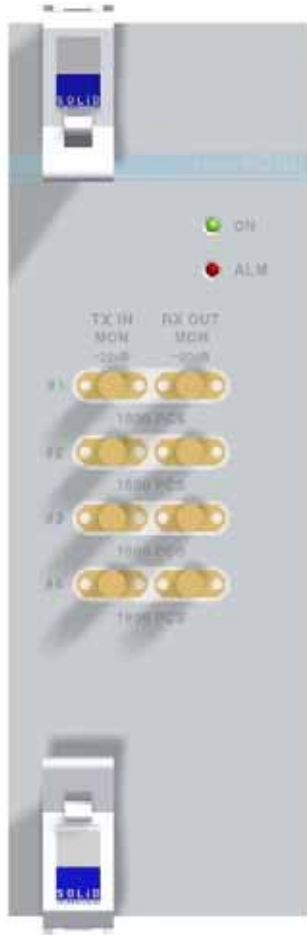

LED		Description
ON	●	Power is not supplied.
	●	Power is supplied.
ALM	●	Normal Operation
	●	Abnormal Operation

MONITOR SMA port seen at the front panel of MDBU enables you to check current level of TX input and RX output signals in current service without affecting main signals. TX MON is -20dB compared with TX Input power and RX MON is -20dB as well compared with RX Output power.

5.1.5 ODU Interface

BIU supports up to four ODUs. At the rear of BIU, eight RF input and output ports for ODU and four power ports for power supply and communication are provided. At BIU, you can check installation information of ODU.

RF Port for interface with ODU

Signal Port for interface with ODU

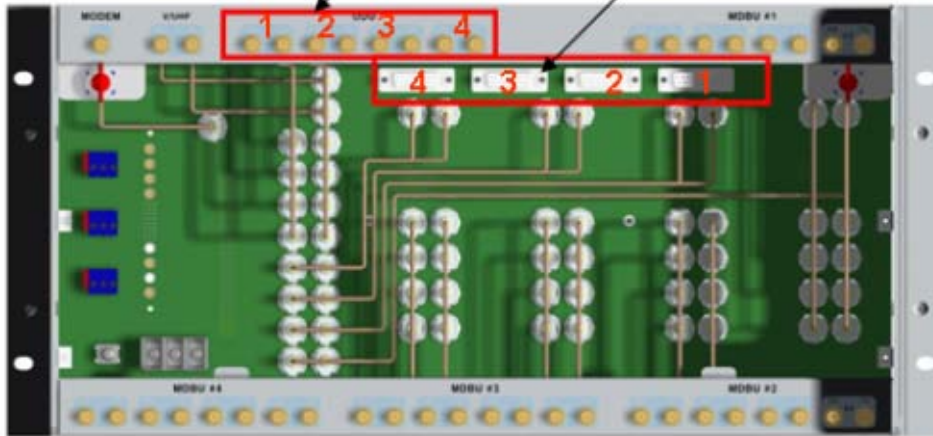

At the rear part of ODU, the number of RF Ports and Signal Ports are printed in order. Therefore, you need to be careful in case of expansion of ODU.

ODU Numbering	RF Port		Signal Port
	TX	RX	
ODU 1	#1		ODU-1
ODU 2	#2		ODU-2
ODU 3	#3		ODU-3
ODU 4	#4		ODU-4

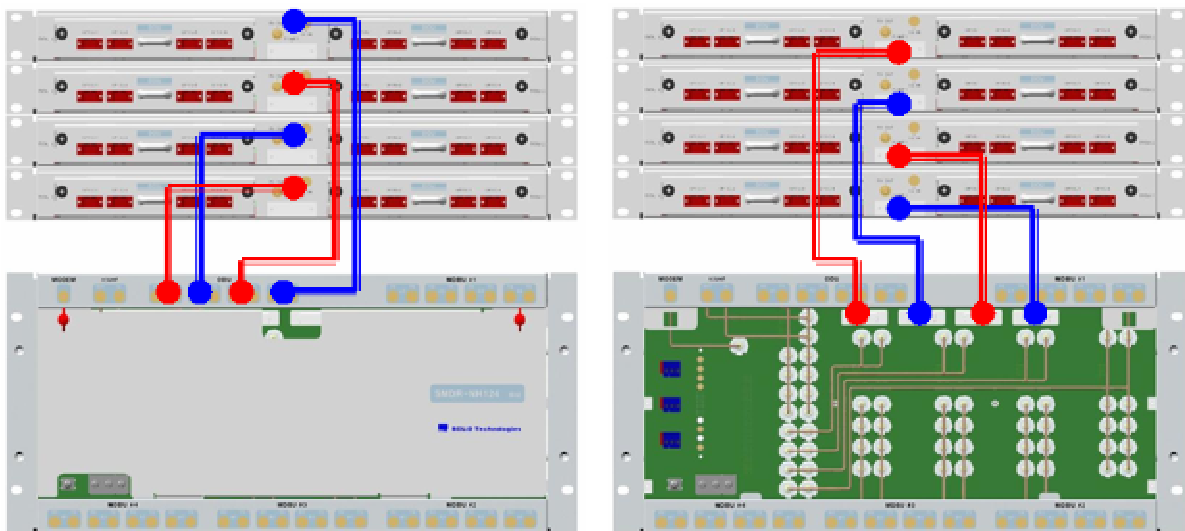



If ODU is not connected in the right order, related devices may fail to communicate with each other or the unit may read wrong information. Given this, you need to connect the unit with accurate RF Port and Signal Port in a corresponding number.



For unused RF Ports for ODU expansion, make sure to terminate them using SMA Term.



When you put ODU on the top of BIU, it is recommended to install the unit at least 1U apart from BIU. Heat from BIU climbs up to reach ODU.

5.1.6 Consumption Power of BIU

The table below shows power consumption of BIU:

Part	Unit	Consumption Power	Remark
Common Part	Shelf	7.5 W	
	MCDU		

	MCPU		
	MPSU		
MDBU	MDBU 800PS	12W	
	MDBU 800PS+900I+Paging	20W	
	MDBU 850C	12W	
	MDBU 850C+700PS	19W	
	MDBU 1900P	20W	
	MDBU AWS-1	12W	
	MDBU 850C+700LTEC	19W	

BIU supplies power for ODU. Therefore, when you want to calculate total power consumption of BIU, you need to add power consumption of ODU to the total value.
Power consumption of ODU is given in the later paragraph describing ODU.

5.2 ODU Installation

ODU should be, in any case, put on the top of BIU. This unit gets required power and RF signals from BIU. The following table shows components of ODU:

No.	Unit	Description	Remark
Common Part	Shelf	Including Main Board, 19",1U	1EA
	RF Cable	SMA(F) to SMA(F), 400mm	2EA
	Signal Cable	2Row(15P_F) to 2Row(15P_M),650mm	1EA
Optional Part	DOU	Optical Module with 4 Optic Port	Up to 2EA to be inserted

5.2.1 ODU Shelf Installation

ODU is a shelf in around 1U size. Its width is 19" and so this unit should be inserted into a 19" Standard Rack. ODU should be, in any case, put on the top of BIU. BIU should be distant around 1U when the unit is installed.

5.2.2 ODU Power Cabling

ODU does not operate independently. The unit should get power from BIU.
When you connect 2-column, 15-pin D-SUB Signal cable from BIU and install DOU, LED on the

front panel is lit. Through this LED, you can check state values of LD and PD of DOU.

5.2.3 ODU Optic Cabling

As optical module shelf, ODU makes electronic-optical conversion of TX signals and then makes optical-electronic conversion of RX signals. ODU can be equipped with up to two DOUs. One DOU supports four optical ports and one optical port can be connected with ROU. Optionally, only optical port 4 can be connected with OEU.

As WDM is installed in DOU, the unit can concurrently send and receive two pieces of wavelength (TX:1310nm, RX:1550nm) through one optical core. DOU has SC/APC of optical adaptor type.



Figure 5.4 – Optical cable of SC/APC Type

For optical adaptor, SC/APC type should be used. To prevent the optical access part from being marred with dirt, it should be covered with a cap during move. When devices are connected through optical cables, you need to clear them using alcohol to remove dirt.

5.2.4 Insert DOU to ODU

In an ODU Shelf, up to two DOUs can be installed. DOU module is in Plug in Play type.

When you insert DOU in ODU, insert the unit into the left DOU1 slot first. You can be careful as the number is silk printed at the left.

The following figure shows installation diagram of ODU with one DOU inserted in it.



The following figure shows installation diagram of ODU with two DOUs inserted in it.



 When you insert DOU into ODU, insert the unit into the left DOU1 slot first. Into unused slot, you need to insert BLANK UNIT in any case.

5.2.5 Consumption Power of ODU

ODU gets power from BIU. One ODU can be equipped with up to two DOUs. Depending on how many DOUs are installed, power consumption varies. The table below shows power

consumption of ODU:

Part	Unit	Consumption Power	Remark
ODU_4	DOU 1 EA	13W	
ODU_8	DOU 2 EA	26W	

5.3 ROU Installation

5.3.1 ROU Enclosure installation

ROU is designed to be water- and dirt-proof. The unit has the structure of One-Body enclosure. It satisfies water-proof and quake-proof standards equivalent of NEMA4.

ROU can be mounted into either of a 19" Standard Rack or on a Wall.

Basically, ROU has both of a Wall Mount Bracket and a Rack Mount Bracket.

Depending on the use of the Rack Mount Bracket, the bracket can be removed.

The following shows dimension of the fixing point for the Wall Mount Bracket.



Figure 5.5 – How to install ROU