

Lucent Technologies
Bell Labs Innovations



5ESS[®] Switch Distinctive Remote Module (DRM)

User's Guide

235-200-150
Issue 3.00P
June 2007



Copyright © 2007 Lucent Technologies. All Rights Reserved.

Alcatel, Lucent, Alcatel-Lucent and the Alcatel-Lucent logo are trademarks of Alcatel-Lucent. All other trademarks are the property of their respective owners.

The information presented is subject to change without notice. Alcatel-Lucent assumes no responsibility for inaccuracies contained herein.

For permission to reproduce or distribute, please contact the Product Development Manager:

1-888-582-3688 (from inside the continental United States).

1-317-322-6416 (from outside the continental United States).

Notice

Every effort was made to ensure that the information in this information product was complete and accurate at the time of publication. However, information is subject to change.

This information product describes certain hardware, software, features, and capabilities of Alcatel-Lucent products. This information product is for information purposes; therefore, caution is advised that this information product may differ from any configuration currently installed.

This 5ESS[®] switch document may contain references to the 5ESS[®] switch, the 5ESS[®]-2000 switch, and the 5ESS[®] AnyMedia[®] Switch. The official name of the product has been changed back to the 5ESS[®] switch. The documentation will not be totally reissued to change these references. Instead, the changes will be made over time, as technical changes to the document are required. In the interim, assume that any reference to the 5ESS[®]-2000 switch or the 5ESS[®] AnyMedia[®] Switch is also applicable to the 5ESS[®] switch. It should be noted that this name change may not have been carried forward into software-influenced items such as input and output messages, master control center screens, and recent change/verify screens.

Conformance Statements

Interference Information: Part 15 of FCC Rules - Refer to the 5ESS[®] Switch Product Specification information product.

Trademarks

5ESS is a registered trademark of Lucent Technologies.

ANSI is a registered trademark of American National Standards Institute, Inc.

BILLDATS is a registered trademark of Lucent Technologies.

Cajun is a trademark of AVAYA, Inc.

Common Language is a registered trademark and CLEI, CLLI, CLCI, and CLFI are trademarks of Bell Communications Research, Inc.

DATAKIT is a registered trademark of Lucent Technologies.

DynaStar 500 is a trademark of DYMEC, Inc.

ESS is a trademark of Lucent Technologies.

Ethernet is a registered trademark of Xerox Corporation.

Netra is a trademark of Sun Microsystems, Inc.

Netscape is a registered trademark of Netscape Communications Corporation.

Paradyne is a registered trademark of AT&T Corp.

Pentium is a registered trademark of Intel Corporation.

SLC is a registered trademark of Lucent Technologies.

SUN is a registered trademark of Sun Microsystems, Inc.

UNIX is a registered trademark in the United States and other countries, licensed exclusively through X/Open Company, Limited.

Windows NT is a registered servicemark of Microsoft Corporation.

Limited Warranty

Warranty information applicable to the 5ESS[®] switch may be obtained from the Alcatel-Lucent Account Management organization. Customer-modified hardware and/or software is not covered by this warranty.

Ordering Information

This information product is distributed by Alcatel-Lucent in Indianapolis, Indiana.

The order number for this information product is 235-200-150. To order, call:

1-888-582-3688 or fax to 1-800-566-9568 (from inside the continental United States)

1-317-322-6847 or fax to 1-317-322-6699 (from outside the continental United States).

Support Information

Information Product Support: To report errors or ask nontechnical questions about this or other information products produced by Alcatel-Lucent, contact Alcatel-Lucent by using one of the following methods:

Use the comment form at <http://www.lucent-info.com/comments/>

Send e-mail to comments@alcatel-lucent.com

Please include with your comments the title, ordering number, issue number, and issue date of the information product, your complete mailing address, and your telephone number.

Technical Support Telephone Numbers: For technical assistance, call Technical Support Services (TSS) at:

1-866-582-3688 (from inside the continental United States)

1-630-224-4672 (from outside the continental United States).

Technical Support Services is staffed 24 hours a day, 7 days a week.

Acknowledgment

Developed by Alcatel-Lucent.

Distinctive Remote Module (DRM)

	CONTENTS	PAGE
1.	INTRODUCTION	1 - 1
2.	5ESS [®] SWITCH DISTINCTIVE REMOTE MODULE	2 - 1
3.	NETWORK PROCEDURES	3 - 1
4.	ADMINISTRATIVE WORKSTATION MAINTENANCE.	4 - 1
5.	ROUTINE MAINTENANCE	5 - 1
6.	CORRECTIVE MAINTENANCE.	6 - 1
7.	SYSTEM RECOVERY	7 - 1
8.	GROWTH AND DEGROWTH	8 - 1
A1.	SUN CONSOLE/MASTER CONTROL CENTER (MCC) TERMINAL SETTINGS	A1-1
A2.	PROCESSOR RECOVERY MESSAGES	A2-1
A3.	ADMINISTRATIVE WORKSTATION (AW) SERIAL ASYNCHRONOUS INTERFACE (SunSAI/P) BOARD GROWTH	A3-1
A4.	DRM SWITCH TO 5ESS [®] SWITCH CONVERSION PROCESS GUIDELINES	A4-1
A5.	5ESS Switch DRM Administrative Workstation NETRA t 1120 to NETRA 20 WITH SOLARIS 8 OS CONVERSION PROCESS GUIDELINES	A5-1
	GLOSSARY	G - 1
	INDEX	I - 1

Distinctive Remote Module (DRM)

CONTENTS		PAGE
1. INTRODUCTION		1 - 1
1.1 PURPOSE		1 - 1
1.2 UPDATE INFORMATION		1 - 1
1.2.1 New in this Issue		1 - 1
1.2.2 Supported Software Releases		1 - 1
1.2.3 Terminology		1 - 1
1.2.4 Lucent Technologies		1 - 2
1.3 ORGANIZATION		1 - 2
1.4 USER COMMENTS		1 - 3
1.5 DISTRIBUTION		1 - 3
1.6 TECHNICAL ASSISTANCE		1 - 4
1.7 SPARES EXCHANGE SERVICE		1 - 4
1.8 FIELD REPLACEABLE UNITS AND SPARES EXCHANGE SERVICE		1 - 5
1.9 RETURN AND REPAIR POLICY		1 - 7
1.9.1 R/S and R Customer Support		1 - 7
1.9.2 Two Methods Of Returning Equipment		1 - 7
1.9.3 RS and R Repair Interval		1 - 8
1.9.4 RS and R Charges		1 - 8
1.10 ON-SITE MAINTENANCE CONTRACTS		1 - 9
1.11 TRAINING		1 - 9
1.12 DOCUMENTATION		1 - 9

LIST OF TABLES

Table 1-1 — DRM Equipment Comcode Numbers	1 - 6
Table 1-2 — RS And R Customer Charges	1 - 9

1. INTRODUCTION

1.1 PURPOSE

This *5ESS*[®] Switch Distinctive Remote Module (DRM) User's Guide is designed to assist office personnel in understanding and maintaining the DRM. This guide contains descriptive material as well as the procedures necessary to perform routine and corrective maintenance, provisioning, and switch administration.

1.2 UPDATE INFORMATION

1.2.1 New in this Issue

This issue of the *5ESS* Switch Distinctive Remote Module (DRM) Module User's Guide has been updated to include new technical information.

1.2.2 Supported Software Releases

In accordance with the *5ESS* Switch Software Support Plan, the 5E14 software release was rated Discontinued Availability (DA) as of September 01, 2004. The information supporting 5E14 and earlier software releases is being removed over time, instead of concurrently, from all documentation.

If you are supporting offices that use a software release prior to 5E15 and you have a need for the information that is being removed, retain the earlier copy of the CD-ROM.

1.2.3 Terminology

1.2.3.1 Communication Module Name Change

The term Communication Module (CM) has been changed to the Global Messaging Server (GMS), representing the new portfolio name of this particular module. The current names of the specific types of the GMS (the CM2 and CM3) have not been changed. Where the CM name has been used in a generic way within this information product, the name will be changed to GMS. Where the specific version of GMS (CM2 or CM3) is being described or mentioned, the name will not be changed. However, the GMS name may be added to the description in certain places as a reminder of the change, and that the particular version is a part of the overall portfolio. The following list provides some examples of how you may see these names used together:

- Global Messaging Server (formerly Communication Module)
- GMS (formerly CM) Global Messaging Server-CM2
- GMS-CM2
- Global Messaging Server-CM3
- GMS-CM3.

These name changes will be made over time as other technical changes are required. Also these changes may not be reflected in all software interfaces (input and output messages, master control center screens, and recent change and verify screens). Where the information product references these areas, the names are used as they are within the software interface.

1.2.3.2 *5ESS*-2000 Switch Name Change

This *5ESS* switch document may contain references to the *5ESS* switch, the *5ESS*-2000 switch, and the *5ESS AnyMedia*[®] Switch. The official name of the product has been changed back to the *5ESS* switch. In the interim, assume that any reference

to the *5ESS-2000* switch or the *5ESS AnyMedia* Switch is also applicable to the *5ESS* switch. It should be noted that this name change may not have been carried forward into software-influenced items such as input and output messages, master control center screens, and recent change/verify screens.

1.2.3.3 Bellcore/Telcordia Name Change

As of March 18, 1999, Bellcore officially changed its name to Telcordia Technologies. Not all pages of this document are being reissued to reflect this change; instead, the pages will be reissued over time, as technical and other changes are required. Customers on standing order for this document may see that, on previous-issue pages, the Bellcore name is still exclusively used.

Customers receiving new orders for this document will see the Telcordia Technologies name used as appropriate throughout the document, and the Bellcore name used only to identify items that were produced under the Bellcore name. Exceptions may exist in software-influenced elements such as input/output messages, master control center screens, and recent change/verify screens. These elements will not be changed in this document until such time as they are changed in the software code. Document updates will not be made specifically to remove historical references to Bellcore.

1.2.4 Lucent Technologies

Lucent Technologies reserves the right to revise this DRM User's Guide for any reason. The reasons for revision will include, but are not limited to, conformity with standards promulgated by *ANSI*¹, Electronic Industrial Association (EIA), International Telegraph and Telephone Telecommunication Standardization Sector (TSS), International Standards Organization (ISO), or similar agencies; utilization of new advances in the state of the technical arts; or to reflect changes in the requirements of communications systems or equipment.

1.3 ORGANIZATION

This user's guide contains the following sections:

- **Section 1 — INTRODUCTION:** States the purpose, update information, supported software releases, and terminology changes.
- **CHAPTER 2 — 5ESS SWITCH DISTINCTIVE REMOTE MODULE:** Provides a description of the DRM including optional terminal interfaces, network interface, and DRM-specific MCC screens.
- **CHAPTER 3 — NETWORK PROCEDURES:** Provides the procedures necessary to setup and maintain the DRM Network.
- **CHAPTER 4 — ADMINISTRATIVE WORKSTATION MAINTENANCE:** Provides procedures used to maintain the DRM AW.
- **CHAPTER 5 — ROUTINE MAINTENANCE:** Provides routine administrative and maintenance procedures, such as software updates, that are performed on a regularly scheduled basis.
- **CHAPTER 6 — CORRECTIVE MAINTENANCE:** Provides maintenance procedures that need to be performed when a fault condition warrants intervention to restore the switching complex equipment to proper operation.

1. Registered trademark of American National Standards Institute.

- **CHAPTER 7 — SYSTEM RECOVERY:** Provides the necessary procedures for recovering the DRM operation after an outage.
- **CHAPTER 8 — GROWTH AND DEGROWTH:** Provides procedures for growing and degrowing hardware.
- **APPENDIX A1 — SUN² CONSOLE/MASTER CONTROL CENTER (MCC) TERMINAL SETTINGS:** Provides a table listing the correct terminal settings for the *Sun* and MCC terminals.
- **APPENDIX A2 — PROCESSOR RECOVERY MESSAGES:** Provides the Processor Recovery Messages (PRMs) unique to the DRM initialization and recovery.
- **APPENDIX A3— ADMINISTRATIVE WORKSTATION (AW) SERIAL ASYNCHRONOUS INTERFACE (SunSAIP) BOARD GROWTH:** Provides the necessary procedures to install and configure the second Serial Asynchronous Interface (SunSAI/P) board into the DRM AW.
- **APPENDIX A4 — DRM SWITCH TO 5ESS SWITCH CONVERSION PROCESS:** Provides the necessary instructions to schedule a conversion of a DRM switch to 5ESS switch (for example, the Administrative Workstation (AW) is being replaced by a 3B21D AM and CM).
- **APPENDIX A5 — 5ESS SWITCH DRM ADMINISTRATIVE WORKSTATION Netra³ T 1120 TO Netra 20 SOLARIS 8 OS CONVERSION PROCEDURE:** Provides the necessary procedure to convert the *Netra* t 1120 Administrative Workstation (AW) in a DRM office to the *Netra* 20 AW.

1.4 USER COMMENTS

We are constantly striving to improve the quality and usability of this information product. Please use one of the following options to provide us with your comments:

- You may use the on-line comment form at <http://www.lucent-info.com/comments>
- You may email your comments to comments@alcatel-lucent.com

Please include with your comments the title, ordering number, issue number, and issue date of the information product, your complete mailing address, and your telephone number.

If you have questions or comments about the distribution of our information products, see Section 1.5, Distribution.

1.5 DISTRIBUTION

For distribution comments or questions, contact your local Alcatel-Lucent Account Representative.

A documentation coordinator has authorization from Alcatel-Lucent to purchase our information products at discounted prices. To find out whether your company has this authorization through a documentation coordinator, call **1-888-582-3688**.

2. Registered trademark of Sun Microsystems, Inc.

3. Trademark of Sun Microsystems, Inc.

Customers who are not represented by a documentation coordinator and employees of Alcatel-Lucent should order *5ESS* switch information products directly from Alcatel-Lucent.

To order, call the following telephone number:

- **1-888-582-3688** or fax to **1-800-566-9568**; from inside the continental United States
- **1-317-322-6847** or fax to **1-317-322-6699**; from outside the continental United States.

1.6 TECHNICAL ASSISTANCE

For technical assistance, call Technical Support Services (TSS) at:

- **1-866-582-3688**; from inside the continental United States
- **1-630-224-4672**; from outside the continental United States.

Technical Support Services is staffed 24 hours a day, 7 days a week.

1.7 SPARES EXCHANGE SERVICE

The spares exchange service for the *5ESS* switch and its related components (SES-5) is a service offering available to North American Region (NAR) customers owning a *5ESS* switch. The SES-5 is designed to provide spare circuit pack and plug-in replacements on an expedited basis by featuring centralized ordering, 24-hours per day/7-days a week telephone order entry, and shortened delivery intervals. The service will provide spare circuit packs and plug-ins normally required to support a *5ESS* switch. The customer has the option of exchanging certain material during warranty and post-warranty periods. These SES-5 features will assist in reducing the level of inventory that must be maintained by the customers for spares.

The SES-5 is an additional service option intended to be a maintenance support service. Its primary purpose is to meet a customer need for immediate replacement of circuit packs or plug-ins while minimizing the amount of total inventory maintained. The customer still has the option to utilize the existing repair service and return procedures (RS and R) to repair material or the traditional hard-copy entry routines to obtain new material. The SES-5 is not intended to be the vehicle for obtaining large quantities of materials associated with establishment of central stocks nor is it intended to be a means of upgrading equipment. These orders should be entered under normal hard-copy routines.

The SES-5 can be used to obtain any circuit pack or plug-in that is typically maintained as a maintenance spare for the *5ESS* switch. Detailed information on equipment and identification of on-site spares can be found in the following drawing.

- J5D052K-3 – 5ESS-2000 SMALL SWITCH SPECIFICATION FOR VERY COMPACT DIGITAL EXCHANGE (VCDX) AND DISTINCTIVE REMOTE MODULE (DRM) FOR U.S. APPLICATIONS FOR SOFTWARE RELEASE 5E16.2

This drawing includes recommended sparing details for the *Netra t1120*, *Netra 20*, and the network. The *5ESS* Switch Spares Exchange Service Catalog (ED4C168-14) is also available and includes the circuit packs eligible for exchange through the SES-5.

Sparing recommendations for *5ESS* switch equipment is provided in ED-5D133-01, which can be obtained from the Customer Information Center in Indianapolis, Indiana.

SES-5 does not support the *Netra 20* and *Netra 240*.

1.8 FIELD REPLACEABLE UNITS AND SPARES EXCHANGE SERVICE

The purpose of the Spares Exchange Service (SES) is to provide customers with immediate replacement of plug-in materials while minimizing total customer spares inventory. This includes both *5ESS* switch circuit packs and the DRM field replaceable units (FRUs) found to be defective. To use this service, contact the regional sales office to complete an Account Requisition form.

The FRUs on the DRM supported by SES include:

- *Netra t 1120* workstation
- *Netra t 1120* DAT drive
- *Netra t 1120* CD/DVD-ROM drive
- *Netra t 1120* Internal disk drives

Note: The DRM *Netra 20* and *Netra 240* FRUs are not supported by SES. RS and R is available for the *Netra 20* and *Netra 240* FRUs as well as an optional on-site support contract from Lucent Worldwide Services.

To place an order for replacement of materials through SES call: **1-800-325-9890**.

Customers will be requested to provide the following information:

- Account number
- Customer "Ship To" address
- Item description, comcode number if applicable (see Table 1-1, and quantity
- Desired "On Job" date
- Shipping Instructions
- Responsible person's name and phone number
- Pertinent billing and accounting information (purchase order number, etc.)
- **IMPORTANT:** To ensure expedited and accurate handling of the returned material, the comcode from the FRU Comcode Table (Table 1-1) that is used to request a replacement from SES must be clearly labeled on the outside of the box the defective unit is returned in. Furthermore, please ensure adequate packing material is used to protect the unit from further damage when returned to SES.

See Table1-1 for the comcode number of the product that needs to be replaced.

Table 1-1 — DRM Equipment Comcode Numbers

Workstation	FRU Description	Comcode Number	Replacement Procedure
Netra t 1120	440Mhz DRM Netra t 1120, 18G drives (2 SAI, 1 HSI, 1 QFE PCI card) (only this Netra t 1120 workstation configuration is stocked in SES. It is the max configuration)	848749404	Procedure 4.6
Netra t 1120	DDS3 DAT Drive	408149086	Procedure 4.11
Netra t 1120	18.2GB Disk Drive	408018513	Procedure 4.5.1
Netra t 1120	CD/DVD-ROM	408537629	Procedure 4.11
The items below this point are not stocked in SES.			
Netra t 1120 ^a	300Mhz DRM Netra t 1120, 18G drives (1 SAI, 1 QFE PCI card)	848590121	Procedure 4.6
Netra t 1120 ^a	300Mhz DRM Netra t 1120, 18G drives (2 SAI, 1 HSI, 1 QFE PCI card)	848611802	Procedure 4.6
Netra t 1120 ^a	300Mhz DRM Netra t 1120, 18G drives (2 SAI, 1 QFE PCI card)	848611828	Procedure 4.6
Netra t 1120 ^a	300Mhz DRM Netra t 1120, 18G drives (1 SAI, 1 HSI, 1 QFE PCI card)	848611836	Procedure 4.6
Netra t 1120 ^a	440Mhz DRM Netra t 1120, 18G drives (1 SAI, 1 QFE PCI card)	848770566	Procedure 4.6
Netra t 1120 ^a	440Mhz DRM Netra t 1120, 18G drives (2 SAI, 1 QFE PCI card)	848770541	Procedure 4.6
Netra t 1120 ^a	440Mhz DRM Netra t 1120, 18G drives (1 SAI, 1 HSI, 1 QFE PCI card)	848770558	Procedure 4.6
Netra 20 ^b	900Mhz DRM Netra 20, 36G drives (1 SAI, 1 QFE PCI card)	848883617	Procedure 4.6
Netra 20 ^b	900Mhz DRM Netra 20, 36G drives (2 SAI, 1 QFE PCI card)	848883625	Procedure 4.6
Netra 20 ^b	900Mhz DRM Netra 20, 36G drives (2 SAI, 1 HSI, 1 QFE PCI card)	848883633	Procedure 4.6
Netra 20 ^b	900Mhz DRM Netra 20, 36G drives (1 SAI, 1 HSI, 1 QFE PCI card)	848883641	Procedure 4.6
Netra 20 ^b	900Mhz DRM Netra 20, 73G drives (1 SAI, 1 QFE PCI card)	848940847	Procedure 4.6
Netra 20 ^b	900Mhz DRM Netra 20, 73G drives (2 SAI, 1 QFE PCI card)	848940854	Procedure 4.6
Netra 20 ^b	900Mhz DRM Netra 20, 73G drives (2 SAI, 1 HSI, 1 QFE PCI card)	848940862	Procedure 4.6
Netra 20 ^b	900Mhz DRM Netra 20, 73G drives (1 SAI, 1 HSI, 1 QFE PCI card)	848940870	Procedure 4.6
Netra 20 ^b	DDS4 DAT Drive	408715829	Procedure 4.12
Netra 20 ^b	36GB Disk Drive	408715811	Procedure 4.5.2 or Procedure 4.5.3
Netra 20 ^b	73GB Disk Drive	408784536	Procedure 4.5.2 or Procedure 4.5.3
Netra 20 ^b	DVD-ROM	408537629	Procedure 4.12
Netra 240 ^b	1.5 Ghz VCDX Netra 240, 146G drives (2 SAI, 1 HSI PCI card)	849005970	Procedure 4.13
Netra 240 ^b	External DAT72 Drive	408923878	Procedure 4.14
Netra 240 ^b	146G SCSI Disk Drive	408923662	Procedure 4.5.4 and 4.5.5
Netra 240 ^b	DVD-RW Drive	408923712	Procedure 4.17
Netra 240 ^b	Power Supply	408924496	Procedure 4.18
Note(s):			
a. Comcode 848749404 should be requested as a compatible replacement from SES. Please ensure that the box the defective Netra t 1120 is returned in has a clearly visible label that specifies Comcode 848749404.			
b. SES-5 does not support this item.			

1.9 RETURN AND REPAIR POLICY

The Repair/ Service and Return (R/S and R) Program is a means by which readily returnable customer equipment is serviced. R/S and R provides warranty verification, generation of appropriate paperwork, tracking, and a single point of contact.

1.9.1 R/S and R Customer Support

Lucent Technologies has many repair locations, and all locations do not repair all products. Therefore, depending upon the product, the unit may go to many different places. Lucent has the policy that a given customer should only have to interact with a single organization for repair issues. The Charlotte Global Provisioning Center is the single point of contact for all material returns for repair. The phone numbers for this center are as follows:

For RBOC (Regional Bell Operating Companies): (800) 432-4398

For all Other Customers: (800) 255-1402

1.9.2 Two Methods Of Returning Equipment

There are two process' techniques a customer can utilize to enter their equipment into the R/S and R; process:

1.9.2.1 Customer Returns Material To Charlotte Global Provisioning Center:

Customers have the option to ship all material that Lucent Technologies repairs and services to the Global Provisioning Center. The Charlotte Global Provisioning Repair Center will source the material, transship items not repaired in-house (i.e. Charlotte Provisioning Center) and do all order processing. The customer must include the following information:

- Customer's purchase order number.
- Description and quantity of units included in the order. For DRM, provide the comcode from the DRM FRU Comcode Table (Table 1-1)
- Description of the problem (include in box with FRU)
- Return Address for the repaired material.
- Whether or not the customer believes the order is under warranty.
- **IMPORTANT:** To ensure expedited and accurate handling of the returned material, the comcode from the FRU Comcode Table (Table 1-1) must be clearly labeled on the outside of the box the defective unit is returned in. Furthermore, please ensure adequate packing material is used to protect the unit from further damage when returned to RS&R.

Address:

Charlotte Global Provisioning Center
10000 Twin Lakes Parkway
Charlotte, NC 28269

1.9.2.2 Customer Direct Ship Material To The Repair Location

Some customers may desire to ship defective material directly to the repair source in the interest of minimizing the repair interval. In this instance, the customer will receive repair source information from the Charlotte Global Provisioning Center. Once again the customer is required to provide the following information:

- Customer's purchase order number.

- Description and quantity of units included in the order. For DRM, provide the comcode from the DRM FRU Comcode Table (Table 1-1)
- Description of the problem (include in box with FRU)
- Return Address for the repaired material.
- Whether or not the customer believes the order is under warranty.
- **IMPORTANT:** To ensure expedited and accurate handling of the returned material, the comcode from the FRU Comcode Table (Table 1-1) must be clearly labeled on the outside of the box the defective unit is returned in. Furthermore, please ensure adequate packing material is used to protect the unit from further damage when returned to RS&R.

1.9.3 RS and R Repair Interval

The RS and R repair interval for DRM FRUs is 14 business days from receipt of defective material to shipment of repaired material.

1.9.4 RS and R Charges

Customer billing is dependent on the warranty status of the equipment. Associated paperwork should indicate warranty status. Eligibility for warranty includes being within the warranty eligibility period and being free of damages from customer tampering or customer abuse. Billing is also dependent upon whether a problem is found with the equipment by the repair location (Trouble Found/TF), or not (No Trouble Found/NTF). Additionally, the equipment in some cases is not repairable, or uneconomical to repair. In these cases, the equipment can be junked by the repair location with customer approval. The following table depicts the customer charges:

Table 1-2 — RS And R Customer Charges

WARRANTY	NTF	TF	TAMPER	ABUSE	UNREPAIRABLE
IN WARRANTY	NTF charge	0	TF charge	TF charge	Replace
OUT OF WARRANTY	NTF charge	TF charge	TF charge	TF charge	Junk with R/SandR Handling charge

For additional information on the Return and Repair policy, see 235-105-110:5ESS *Switch System Maintenance Requirements and Tools*, section "Repair Service and Return Procedures."

1.10 ON-SITE MAINTENANCE CONTRACTS

Lucent Worldwide Services (LWS) offers an optional on-site maintenance contract for the Sun Microsystems components of all of the DRM configurations. This optional service provides for on-site repair to avoid the need for maintaining spares and to avoid delays in shipping defective hardware to SES or R/SandR for replacement/repair. For more information, contact your LWS sales representative.

1.11 TRAINING

The self paced multimedia course, ES5M03D, *5ESS Switch Distinctive Remote Module (DRM) Maintenance Training*, is available. For course information, access the Lucent Product Training Catalog on-line at <https://www.lucent-product-training.com/SabaWeb/>.

To order the multimedia course call **1-888-LUCENT8 (1-888-582-3688)**, prompt 2.

1.12 DOCUMENTATION

Note: The procedures in 235-200-150, *5ESS Switch Distinctive Remote Module (DRM) User's Guide*, have been customized for DRM and therefore may be different from those appearing in the *5ESS switch core documentation*.

The 235-200-145, *5ESS Switch OneLink Manager™ Administrative Services Module (ASM) User's Guide*, can be accessed by selecting the library button on any of the ASM GUI pages.

The following *5ESS switch core documents* are referenced at various locations within this document:

- 235-040-100, *5ESS Switch Operations, Administration, and Maintenance Planning Guide*
- 235-070-100, *5ESS Switch Administration and Engineering Guidelines*
- 235-080-100, *Translations Guide (TG-5)*
- 235-100-125, *5ESS Switch System Description*
- 235-105-110, *5ESS Switch System Maintenance Requirements and Tools*
- 235-105-210, *5ESS Switch Routine Operations and Maintenance Procedures*
- 235-105-220, *5ESS Switch Corrective Maintenance Procedures*
- 235-105-231, *5ESS Switch Hardware Change Procedures - Growth*
- 235-105-331, *5ESS Switch Hardware Change Procedures - Degrowth*
- 235-118-2XX, *5ESS Switch Recent Change Reference and Recent Change Procedures*

- 235-190-103, **5ESS** *Switch Business and Residence Feature Descriptions*
- 235-190-104, **5ESS** *Switch ISDN Feature Descriptions*
- 235-190-115, **5ESS** *Switch Local and Toll System Feature Descriptions*
- 235-190-130, **5ESS** *Switch Local Area Signaling Services*
- 235-200-115, **5ESS** *Switch CNI Common Channel Signaling*
- 235-200-145, **5ESS** *Switch OneLink Manager Administrative Services Module (ASM) User's Guide*
- 235-600-112, **5ESS** *Switch Translations Data Manual*
- 235-600-3XX, **5ESS** *Switch ECD/SG Database Manual*
- 235-600-400, **5ESS** *Switch Audits Manual*
- 235-600-500, **5ESS** *Switch Asserts Manual*
- 235-600-700, **5ESS** *Switch Input Messages Manual*
- 235-600-750, **5ESS** *Switch Output Messages Manual*
- 235-700-100, **5ESS** *Switch Interface/Compatibility Guide*
- 235-700-200, **UNIX**⁴ *System Reference Manual*.
- 235-900-402, *ASM to DRM Network Components Interface Description*.

Other Documentation referenced in this document include:

- Avaya Cajun P333T Stackable Switch User's Guide. For the latest copy go to <http://support.avaya.com/elmodocs2/p330/P333T/p333t33ug.pdf>
- *Dynastar 100/100i/100e/500*⁵ Multi-Service Switches Installation And User Guide

For latest copy go to www.dynastarcom.com.

4. Registered trademark in the United States and other countries licensed exclusively through X/Open Company Limited

5. Trademark of DYMEC, Inc.

Distinctive Remote Module (DRM)

CONTENTS		PAGE
2.	5ESS [®] SWITCH DISTINCTIVE REMOTE MODULE	2 - 1
2.1	Overview	2 - 1
2.1.1	Using 5ESS Switch Core Documentation	2 - 1
2.2	ASM Interface for DRM Monitoring and Maintenance	2 - 2
2.3	DRM Architecture	2 - 2
2.4	DRM Hardware.	2 - 3
2.4.1	Administrative Workstation (AW) Hardware	2 - 4
2.4.2	Netra 240 System Overview	2 - 8
2.4.3	Switching Module Hardware	2-10
2.5	Alarms	2-13
2.5.1	Alarm Status Unit (ASU)	2-13
2.6	Capacities	2-13
2.6.1	Switching Modules	2-13
2.6.2	Lines and Trunks	2-13
2.7	The DRM Network	2-13
2.7.1	Introduction	2-13
2.7.2	Network Requirements	2-14
2.7.3	Functions	2-14
2.7.4	The Operational Support (OSS) Systems	2-17
2.7.5	Network Component Maintenance Screens	2-18
2.8	Optional Local Terminal Interfaces	2-19
2.9	Types of Terminal Interfaces and Operating Support Systems	2-21
2.9.1	Serial Interface	2-22
2.9.2	High-Speed Interface.	2-25
2.9.3	Quad Fast Ethernet (QFE) Interface (Netra t 1120 and Netra 20).	2-28
2.9.4	Broadcom Gigabit Ethernet(BGE) Interface (Netra 240)	2-30
2.9.5	Master Control Center (MCC)	2-31
2.9.6	Receive-Only Printer (ROP)	2-53
2.9.7	Supplemental Trunk and Line Work Station (STLWS).	2-56
2.9.8	Recent Change (RC/V)	2-56
2.9.9	SCANS Data Link	2-57
2.9.10	Automatic Message Accounting (AMA) Data Link.	2-59
2.9.11	Switching Control Center System (SCCS) Data Link	2-60
2.9.12	EADAS	2-60
2.10	Terminal Security.	2-60
2.11	DRM Software	2-60

2.11.1	Administrative Workstation (AW) Software	2-60
2.11.2	Switching Module Software	2-62
2.12	Features	2-62
2.12.1	Signaling System 7 (SS7)	2-62
2.12.2	Session Initiation Protocol (SIP)	2-62
2.12.3	Automatic Message Accounting (AMA).	2-62
2.12.4	AMADNS	2-62
2.12.5	Software Release Retrofit	2-62
2.12.6	Software Release Update	2-63
2.12.7	Software Update	2-63
2.12.8	Features Not Supported in the DRM	2-67

LIST OF FIGURES

Figure 2-1	— Switching Complex Architecture	2 - 3
Figure 2-2	— <i>Netra t 1120</i>	2 - 4
Figure 2-3	— <i>Netra 20</i>	2 - 5
Figure 2-4	— <i>Netra 240</i>	2 - 5
Figure 2-5	— Administrative Workstation Interface Configuration (<i>NETRA t 1120</i>)	2 - 7
Figure 2-6	— Administrative Workstation Interface Configuration (<i>NETRA 20</i>).	2 - 7
Figure 2-7	— Administrative Workstation Interface Configuration (<i>NETRA 240 Workstation</i>)	2 - 8
Figure 2-8	— <i>Ethernet</i> and CPI Interface.	2 - 1 1
Figure 2-9	— The Lucent Network Component Solution (LNCS) Architecture	2-14
Figure 2-10	— Host Site Hardware Components.	2-16
Figure 2-11	— DRM Site Hardware Components.	2-17
Figure 2-12	— Operational Support Systems	2-18
Figure 2-13	— Administrative Workstation Terminal Interface Connections (<i>Netra t 1120</i>)	2-19
Figure 2-14	— Administrative Workstation Terminal Interface Connections (<i>Netra 20</i>).	2-20
Figure 2-15	— Administrative Workstation Terminal Interface Connections (<i>Netra 240</i>)	2-20
Figure 2-16	— Serial Asynchronous Interface (SAI) for <i>Netra t 1120</i>	2-23

Figure 2-17 — Serial Asynchronous Interface (SAI) for <i>Netra</i> 20	2-24
Figure 2-18 — Serial Asynchronous Interface (SAI) for <i>Netra</i> 240	2-24
Figure 2-19 — <i>NETRA</i> t 1120 Workstation High-Speed Interface to AW Connections	2-25
Figure 2-20 — <i>NETRA</i> 20 Workstation High-Speed Interface to AW Connections	2-26
Figure 2-21 — <i>NETRA</i> 240 Workstation High-Speed Interface to AW Connections	2-27
Figure 2-22 — Quad Fast <i>Ethernet</i> - <i>Netra</i> t 1120 Interface Connections	2-28
Figure 2-23 — Quad Fast <i>Ethernet</i> - <i>Netra</i> 20 Interface Connections	2-29
Figure 2-24 — <i>BroadcomGigabit Ethernet</i> — <i>Netra</i> 240 Interface Connections	2-30
Figure 2-25 — KS-22396 MCC Interface to Administrative Workstation - <i>Netra</i> t 1120	2-31
Figure 2-26 — KS-22396 MCC Interface to Administrative Workstation - <i>Netra</i> 20	2-32
Figure 2-27 — KS-22396 MCC Interface to Administrative Workstation - <i>Netra</i> 240	2-32
Figure 2-28 — KS-24697 MCC Interface to Administrative Workstation (<i>NETRA</i> t 1120).	2-33
Figure 2-29 — KS-24697 MCC Interface to Administrative Workstation (<i>NETRA</i> 20)	2-34
Figure 2-30 — KS-24697 MCC Interface to Administrative Workstation (<i>NETRA</i> 240).	2-34
Figure 2-31 — MCC Page Display Design	2-36
Figure 2-32 — Typical MCC Display Page	2-37
Figure 2-33 — Emergency Action Interface (EAI) Page	2-38
Figure 2-34 — MCC Display Page 111,112 AM, AM Peripherals	2-43
Figure 2-35 — MCC Display Page 113	2-45
Figure 2-36 — Miscellaneous Status Summary - MCC Display Page 116	2-46
Figure 2-37 — MCC Display Page 124	2-48
Figure 2-38 — MCC Display Page 1190	2-49

Figure 2-39 — MCC Display Page 1400	2-50
Figure 2-40 — MCC Video Terminal With Function Keys.	2-51
Figure 2-41 — STLWS and ROP Interface - <i>Netra t 1120</i>	2-54
Figure 2-42 — STLWS and ROP Interface - <i>Netra 20</i>	2-55
Figure 2-43 — STLWS and ROP Interface - <i>Netra 240</i>	2-55
Figure 2-44 — SCANS/AMA/SCCS/Optional OSS Interface - <i>Netra t 1120</i>	2-57
Figure 2-45 — SCANS/AMA/SCCS/Optional OSS Interface - <i>Netra 20</i>	2-58
Figure 2-46 — SCANS/AMA/SCCS/Optional OSS Interface - <i>Netra 240</i>	2-59
Figure 2-47 — AW Software Architecture	2-61

LIST OF TABLES

Table 2-1 — Disk Drive Capacities	2 - 4
Table 2-2 — <i>Netra 240</i> Workstations Terminal Port Assignments	2 - 9
Table 2-3 — TSICOM External Timing Reference Cables.	2-12
Table 2-4 — Terminal Interface Devices	2-22
Table 2-5 — <i>Netra t 1120</i> and <i>Netra 20</i> Terminal Port Assignments	2-23
Table 2-6 — High-Speed Port Assignment	2-28
Table 2-7 — QFE Port Assignment	2-30
Table 2-8 — BGE Port Assignments	2-31
Table 2-9 — Emergency Action Indications and Qualifiers	2-40
Table 2-10 — Emergency Action Interface (EAI) Maintenance Commands.	2-42
Table 2-11 — Features Not Supported in the DRM	2-67

2. 5ESS[®] SWITCH DISTINCTIVE REMOTE MODULE

2.1 Overview

The 5ESS Switch Distinctive Remote Module (DRM) is a remote architecture based on the SM-2000 architecture with no back-hauled voice or data traffic. Each DRM consists of a single SM-2000, an Administrative Workstation and a commercially remoted *Ethernet*¹ connection to the 5ESS switch via the ASM referred to as the "Host." A Switching Complex provides a common set of maintenance terminals and data links off of an Administrative Services Module (ASM), which can support a 5ESS switch (3B21D, CM2, and SMs/SM-2000s) and up to 15 DRMs.

Note: Although local terminal interfaces and operating support systems (discussed later in this chapter) can be used for monitoring and maintaining a DRM, it is recommended that these functions be performed via the terminals and data links through the ASM. See "ASM Interface for DRM Monitoring and Maintenance," Section 2.2.

The DRM provides services such as Plain Old Telephone Service (POTS), equal access, Integrated Services Digital Network (ISDN) and Centralized Telephone Communications Exchange Service (CENTREX).

The DRM provides:

- A central monitoring and maintenance center for up to 15 DRMs
- Virtually non-blocking access between non-concentrated switch terminations
- Integration of voice and digital data services into a single switch
- Direct digital interfacing with digital facility terminations
- Signaling and transmission treatment by an interface unit
- Testing access to modular metallic facilities as an integral part of the interface units
- Evolution potential to full-size 5ESS switch.
- The OIU OC-3 SONET capability is supported on the VCDX and DRM platforms.

High capacity DRM can support up to 55K lines and 10K trunks under the 65K maximum circuits limitation. The high capacity DRM configuration should be an SM2K (SMPU4 or SMPU5) or SM-XC (SMU6) that is equipped with a *Netra*² 240 AWS, a Core 700 Processor, and a MHPPC. The analog lines will be terminated on XAIUs. PSU2's will be used for SS7 signaling.

2.1.1 Using 5ESS Switch Core Documentation

This user's guide should always be referenced first by DRM owners. This document contains all DRM specific procedures which do not appear in any other 5ESS switch documentation. If further detail or explanation is required or if needed information does not appear in this document, the 5ESS switch core documentation provided on CD-ROM may be examined. The primary usage of the CD-ROM documentation by DRM personnel will most likely be for ASM information or for referencing the 235-600-700, *Input Messages Manual* and the 235-600-750, *Output Messages Manual*.

1. Registered trademark of Xerox Corporation.

2. Trademark of Sun Microsystems, Inc.

Note that while the DRM emulates the hardware of the AM and simulates the functions of the CM2, the software associated with the AM and CM2/CMP hardware is still present in the Administrative Workstation (AW). Portions of this document refer to the AM and CM2/CMP. The reader should note that references to these items are not referring to the hardware but rather the software associated with the AM and CM2/CMP.

Whenever the 5ESS switch core documentation is referred to, the reader must be advised that the documentation was **not** modified to reflect that the DRM utilizes an emulated AM and CM2 and does not have the actual AM and CM2 hardware. Furthermore, procedures that deal with AM/CM2 hardware will be present on the CD-ROM and should be ignored by DRM personnel.

2.2 ASM Interface for DRM Monitoring and Maintenance

The DRM is monitored and maintained remotely via the Administrative Services Module (ASM). The ASM provides access to smart maintenance terminals/PCs, high speed data links, and OA&M functionality for the entire Switching Complex. The user interface on these terminals/PCs is called a Graphical User Interface (GUI) or ASM GUI pages. The ASM architecture, administration, maintenance, and the GUI look and usage, can be found in the 235-200-145, **5ESS Switch OneLink Manager™ Administrative Services Module (ASM) User's Guide**.

2.3 DRM Architecture

To best understand the DRM architecture, a brief description of the architecture of the 5ESS switch is appropriate. The 5ESS switch, equipped with an ASM, is composed of four major components:

- **Administrative Services Module (ASM)** - provides a remote human interface for administrative and maintenance functions of the Switching Complex. For information regarding ASM, see 235-200-145, **5ESS Switch OneLink Manager Administrative Services Module (ASM) User's Guide**.
- **3B21D Administrative Module (AM)**— provides administration and maintenance capabilities.
- **Communications Module 2 (CM2)**— interconnects the AM to the switching modules and provides a sophisticated switching and message network.
- **Switching Module (SM-2000)**— provides terminations of lines and trunks to a switching fabric which has the flexibility to support Plain Old Telephone Service (POTS), Integrated Services Digital Network (ISDN), Operator Services Position System (OSPS), Signaling System 7 (SS7), IP packet trunking with SIP signaling, and tandem and wireless applications.

The DRM combines the functions of the AM and CM2 onto an Administrative Workstation (AW) which uses an *emulated* AM while running the same AM and CM2 software. The DRM supports a single SM-2000, which contains special hardware to allow it to communicate with the AW. In addition, all call processing functions have been migrated to the DRM SM-2000 so that all calls can complete should the AW become unavailable.

For the DRM, the terminal interfaces are remote through the ASM or they can be connected to the AW locally. The 5ESS switch has terminal interfaces connected to the AM's Input/Output Processor (IOP). The IOP contains the hardware to provide front end processing for the various terminal devices. For the DRM, the emulated AM on

the AW contains assist processes which convert I/O messages sent to the AM IOP by the AM software to messages which can be sent to the terminal interfaces attached to the AW.

The SM-2000 portion of the DRM communicates with its local AW via the Message Handler *Ethernet* Interface Board (MHEIB). An *Ethernet* switch can be used to multiplex 10BaseT links between the DRM AW and a multi-service access device. A multi-service access device can then be used to transmit data signals over a DS1 for transport over a commercial data network back to the Host. In addition, the multi-service access device can be used to transmit HSI and SAI data signals. Another multi-service access device is used at the Host to convert back to a 100BaseT *Ethernet* interface, which is connected to an *Ethernet* switch, which then multiplexes to the Administrative Services Module (ASM) (see 235-200-145, **5ESS Switch OneLink Manager Administrative Services Module (ASM) User's Guide**). The ASM provides access to smart maintenance terminals, high speed data links, and OA&M functionality for the entire Switching Complex (a 3B21D/CM2 and up to 15 DRMs). The maximum number of SM-2000s in the Switching Complex is 23, of which 15 may be DRMs. There is no connection from a DRM to a 3B21D or a CM2.

2.4 DRM Hardware

The DRM is composed of two major components:

- **Administrative Workstation (AW)** - consists of a frame mounted workstation running the AM and CM2 emulated software.
- **Switching Module (SM-2000)** - performs all call processing functions and has the flexibility to support Plain Old Telephone Service (POTS), Integrated Services Digital Network (ISDN), and tandem and wireless applications.

Figure 2-1 illustrates the architecture for the Switching Complex.

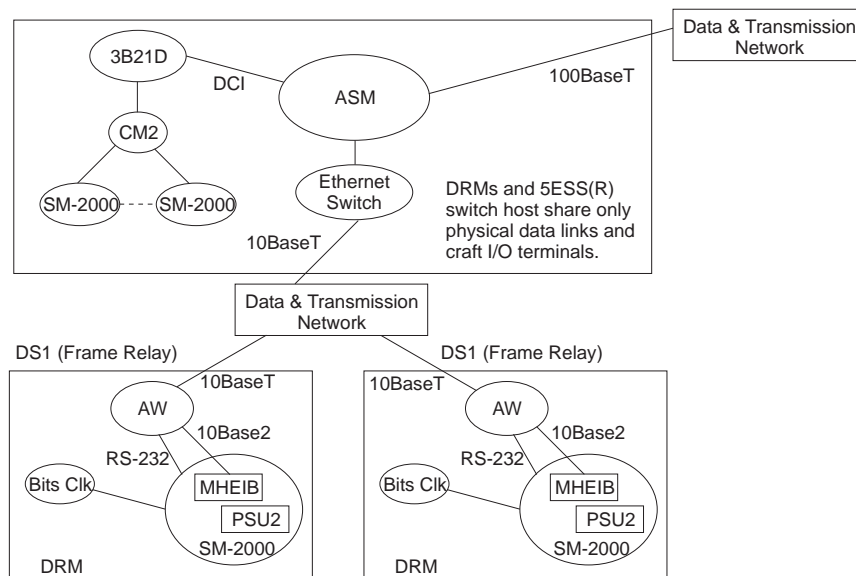

Maximum of 15 DRMs in a Switching Complex
DS1 per DRM

Figure 2-1 — Switching Complex Architecture

2.4.1 Administrative Workstation (AW) Hardware

The AW can be one of the following workstations equipped with a Master Control Center (MCC), keyboard, CPU, two hard disk drives, DAT tape drive, and CD ROM *Netra t 1120* or DVD (*Netra 20* and *Netra 240*) drive as follows:

- *Netra t 1120* workstation, shown in Figure 2-2.
- *Netra 20* workstation, shown in Figure 2-3.
- *Netra 240* workstation, shown in Figure 2-4.

The AW also provides an *Ethernet* Interface for communication and data transfer to the ASM and SM, a Serial Interface for terminal connections and a High Speed Interface (HSI) for data link connections

The *Netra t 1120* and *Netra 20* are equipped with internal disk and DAT tape drives. The *Netra 240* is equipped with internal disk drives and an external DAT tape drive. See Table 2-1 for a list of disk drive capacities.

Table 2-1 — Disk Drive Capacities

Disk Drive	5E16.2 and Later Releases
<i>Netra t 1120</i>	9GB/18GB ^b
<i>Netra 20</i>	36GB ^a
<i>Netra 240</i>	146GB ^b
Note(s):	
a. Fibre Channel Arbitrated Loop (FC-AL) Drive	
b. Small Computer System Interface (SCSI) Drive	



Figure 2-2 — *Netra t 1120*



Figure 2-3 — Netra 20

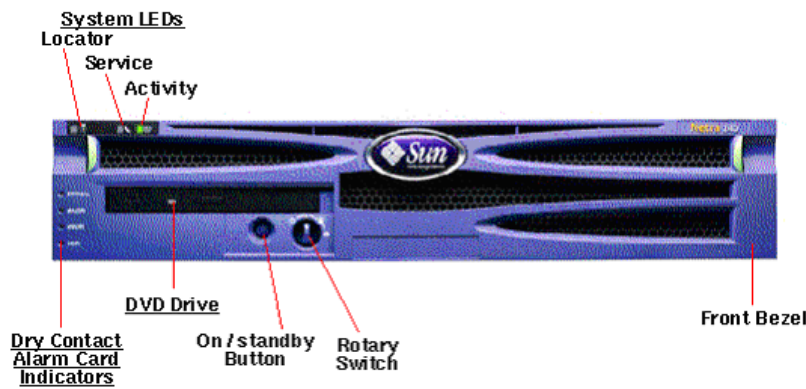

Figure 2-4 — Netra 240

The AW provides administrative and maintenance software for the DRM. It is equipped with a mirrored disk for reliable storage of software applications and data. The AW contains an AM emulator and a simulated CM2 to emulate what is found on the 5ESS switch. The AW oversees many of the global administrative operations required in the DRM. These operations include storing Automatic Message Accounting (AMA), monitoring system configurations, and providing backup storage for application programs. The AW provides local human-machine interface with the DRM. The AW is not involved in call processing. Therefore, there is no call processing impact if the AW were to encounter a fault during operation.

In case of an AW outage, the switching module is capable of storing 72 hours of AMA data before requiring download to the AW for storage on the hard disk. A switching module circular AMA data buffer protects AMA data by ensuring that certain pointers in the AMA storage area are not updated until the AMA data can be retrieved once the AW is restored.

The following interface connectors, which are depicted in Figures 2-5, 2-6 and 2-7 allow peripheral devices and terminals to be interfaced to the AW. Any peripheral interface connectors not listed below are unused by the DRM application. See Section

2.8, “*Optional Local Terminal Interfaces*” for more information on terminal and data link devices.

- SCSI port (*Netra 240*) – used to connect the DAT drive unit to the workstation.
- *Ethernet Quad Fast Ethernet (QFE) port 0 (Netra t 1120, Netra 20)* – interface between the AW and the ASM to establish a network connection between the DRM and the 5ESS Switch. The *Ethernet* cable uses an RJ-45 to interface the hub or router. This cable is used for the network connection to the ASM.
- *Ethernet Broadcom³ Gigabit Ethernet⁴ (BGE) port 2 (Netra 240)* – interface between the AW and the ASM to establish a network connection between the DRM and the 5ESS Switch. The *Ethernet* cable uses an RJ-45 to interface the hub or router. This cable is used for the network connection to the ASM.
- *Ethernet port* – interface between the AW and the SM. The *Ethernet* cable uses a tee-connector to interface both sides of the Module Controller/Time Slot Interchanger (MCTSI) .
- PCI slots (*Netra t 1120, Netra 20, and Netra 240*) – support the High Speed Interface (HSI) card for data link connections and Serial Asynchronous Interface (SAI) cards for terminal and printer connections.
- Serial port DB-9 (*Netra 240*) – used to connect the *Solaris*⁵ console terminal to the AW.
- Serial ports A and B (*Netra t 1120 and Netra 20*) – serial port A is used to connect the *Solaris* console terminal to the AW. Serial port B is used to connect the MCC terminal to the AW.
- Parallel port (*Netra t 1120 and Netra 20*) – used to connect a ROP to the AW.

3. Registered trademark of Xerox Corporation.

4. Registered trademark of Xerox Corporation.

5. Registered trademark of Sun Microsystems, Inc.

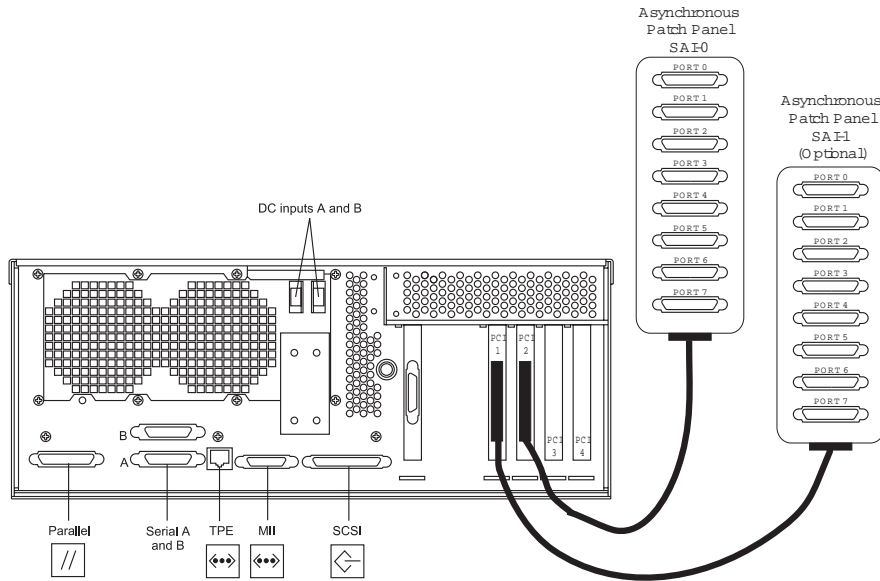

Figure 2-5 — Administrative Workstation Interface Configuration (NETRA t 1120)

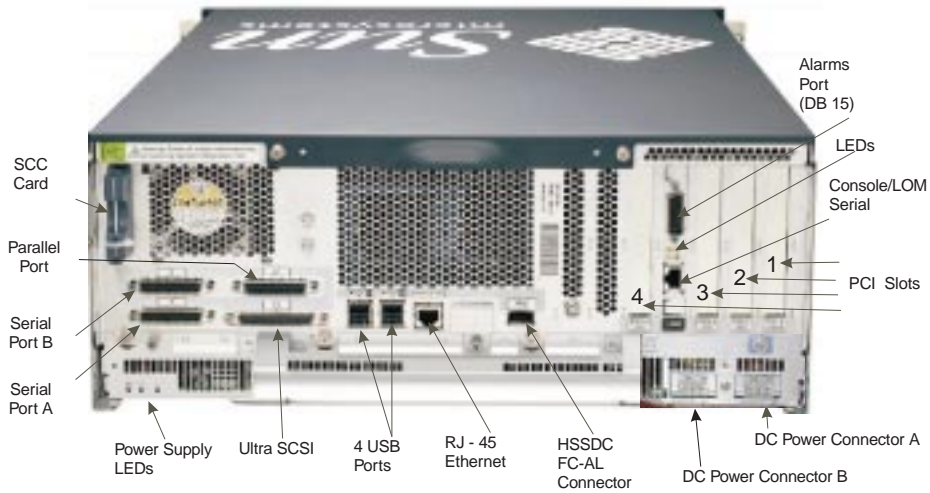

Figure 2-6 — Administrative Workstation Interface Configuration (NETRA 20)

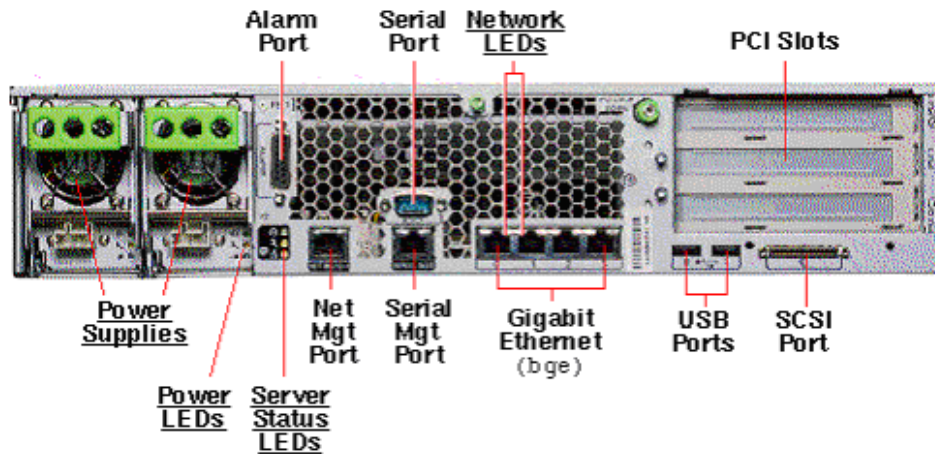

Figure 2-7 — Administrative Workstation Interface Configuration (NETRA 240 Workstation)

2.4.2 Netra 240 System Overview

The *Netra 240 AW*, running the *Solaris 8 2/04* Operating System, is the replacement for the *Netra 20 AW*. The *Netra 240 AW* supports the following hardware:

- 1 - 1.5Ghz CPU
- 1GB memory
- 2 - 48VDC PSUs (Power Supply Units)
- 2 -146GB SCSI internal drives
- 1 - DVD-RW internal drive
- 2 - SAI PCI cards
- 1 - HSI PCI card
- 1 - DAT72 SCSI external drive

The *Netra 240 AW* has the following differences from the *Netra t 1120* and *Netra 20 AW*.

- The A and B DB-25 serial ports, that were provided on the *Netra t 1120* and *Netra 20*, are not provided on the rear of the *Netra 240*. Instead a single DB-9 serial port is provided and will be used to connect a terminal for access to the *Netra 240 Solaris Console*. The *Netra 240 MCC* will be connected to a serial port on a SAI card. See section 2.9.5 “Master Control Center”.
- A parallel port is not provided on the rear of the *Netra 240*. As a result, the *Netra 240 ROP* is connected to a serial port on a SAI card. See section 2.9.6 “Receive-Only Printer”.
- The *Netra t 1120* and *Netra 20* SAI cards provided support for a maximum of 14 terminal devices. Since the *Netra 240 MCC* and *ROP* occupy 2 SAI ports, a

- maximum of 12 terminal devices can be equipped on the *Netra* 240. See Table 2-2 for a list of the serial port assignments for the *Netra* 240 terminal devices.
- The *Netra* 240 AW is equipped with hot swappable 48V PSUs (Power Supply Unit). The PSU replacement procedure is provided in Section 4.18 “Replace a Power Supply Unit (*Netra* 240)”.
 - The DAT72 (Digital Audio Tape 72GB) tape drive is external to the *Netra* 240. The DAT72 drive requires DDS3, DDS4, or DAT72 tape cartridges. The *Netra* 240 does not support DDS1 and DDS2 formatted tapes. The DAT72 replacement procedure is provided in Section 4.14 “Replace a DAT Tape Drive Unit (*Netra* 240)”.
 - The *Netra* 240 DVD drive supports read and write capability. However, the DRM application will not provide any procedure to use the *Netra* 240 DVD write capability. The DRM application will not block any *Solaris* application from using the DVD write capability. The DVD replacement procedure is provided in Section 4.17 “Replace a DVD Drive (*Netra* 240)”.
 - The DRM application will not provide any procedure to use or support the *Netra* 240 ALOM (Automatic Lights Out Management Module) functionality. The DRM application will not block any *Solaris* application from using the ALOM functionality.

Table 2-2 — *Netra* 240 Workstations Terminal Port Assignments

SAI No.	PCI Slot No.	SAI Port	Terminal Device
0	1	0	Reserved (CPI Side 0)
0	1	1	Reserved (CPI Side 1)
0	1	2	Note ^a
0	1	3	Note ^a
0	1	4	Note ^a
0	1	5	Note ^a
0	1	6	Note ^a
0	1	7	Note ^a
1	0	0	Note ^a
1	0	1	Note ^a
1	0	2	Note ^a
1	0	3	Note ^a
1	0	4	Note ^a
1	0	5	Note ^a
1	0	6	Reserved for MCC
1	0	7	Reserved for ROP
Note(s):			
a. Terminal devices can be STLWS, RC/V Terminal, Traffic Printer, or Office Record Printer.			

2.4.3 Switching Module Hardware

The switching module provides terminations for all lines, trunks, and service circuits within the DRM. It performs the call processing functions and time division switching. It is capable of stand-alone billing and can be configured to meet the needs of many applications. It requires some common units and can accommodate many peripheral units. For information on call processing, see 235-145-100, **5ESS Switch Call Processing Description**.

Common Units are those units required in a switching module. The common units include:

- The Module Controller/Time Slot Interchange (MCTSI)
- The *Ethernet* Interface Board (EIB)
- T1/E1 External Reference Timing
- Digital Service Control Unit

2.4.3.1 The Module Controller/Time Slot Interchange (MCTSI)

The Module Controller/Time Slot Interchange (MCTSI) includes the Switching Module Processor Unit Model 5 (SMPU5) and Time Slot Interchange Unit Model 4, Version 2 (TSIU4-2) which provides all necessary call processing and maintenance functions in the switching module. It operates in an active/standby configuration so that in the event of a fault, the active processor switches to the standby side without losing any stable calls.

2.4.3.2 The *Ethernet* Interface Board (EIB)

The SM-2000 utilizes an MHEIB circuit pack to provide all communications and data transfers between the SM-2000 and the AW.

The *Ethernet* link is terminated on an *Ethernet* paddleboard (982AAH) connected to the backplane of MHEIB. The *Ethernet* interface paddleboard is a small square circuit board that contains circuitry and a coaxial connector jack used to connect the MHEIB. *Ethernet* communications are handled internally by the SMP. Refer to Figure 2-8.

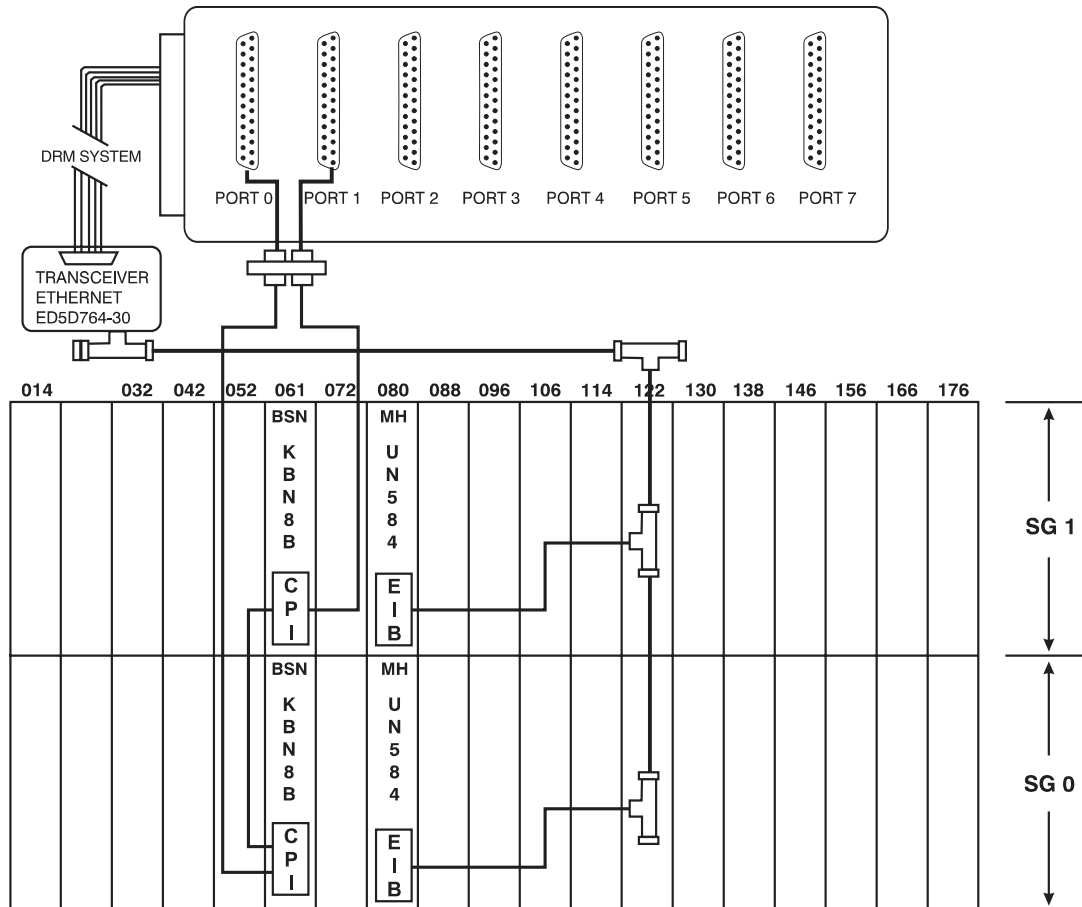

Figure 2-8 — Ethernet and CPI Interface

2.4.3.3 Central Processor Intervention (CPI)

Central Processor Intervention (CPI) is a high priority method of communication between the workstation and the SM-2000 that bypasses the normal communication protocol.

CPI messages are sent over the workstation's RS-232 ports (ports 0/1) to the CPI paddleboards (982YN) on the SM-2000 backplane. The CPI is a square circuit board that contains circuitry and connects through the SM-2000's backplane into its respective circuit pack. Additionally, on its outside edge there are two modular telephone jack receptacles. One is used to terminate the cable connected to the Serial/Parallel patch panel and the other is used to terminate a cable connecting the CPI paddleboard equipped in MCTSI 0 to the CPI paddleboard equipped in MCTSI 1. The CPI's primary functions are to control forcing/clearing conditions on the MCTSI, control the sanity timer and provide for TMS switching. Refer to Figure 2-8.

The CPI paddleboards' top jacks are cross-connected between service groups to allow for mirroring of information being sent to it.

For more information about CPI, see 235-100-125, *5ESS Switch System Description*, 235-600-700, *Input Messages Manual* or 235-600-750, *Output Messages Manual*.

2.4.3.4 T1/E1 External Reference Timing

The T1/E1 external reference timing is provided by a TSICOM.

For synchronization with the network, an external timing source should be connected to the TSICOM. The source can either be the incoming digital trunks, or a BITS box, if so equipped. Without proper synchronization, timing slips may occur leading to digital facilities being taken out of service.

Table 2-3 — TSICOM External Timing Reference Cables

Cable Type	Application
G454	Links TSICOM (UM74C) to a BITS clock or DSX Bridging Repeater. Non-EMC, 24 channels, 100 ohms, 0.772 Mb/s. (References ED5D675-17 G26 and G27 for the actual cables for Side 0 and Side 1).
G455	Same as G454 but with EMC treatment .

The cable used to connect the external clock reference to the SM-2000 is ordered from ED5D500-21 (see Figure 5.11-1). Depending on the application, one of the cable types from Table 2-3 must be ordered.

2.4.3.5 Digital Service Control Unit

The Digital Service Control (DSC) provides the tone generation (for example, audible ring and dial tone) and tone decoding (for example, digit interpretation) functions required by every switching module.

2.4.3.6 Peripheral Units (PUs)

Peripheral Units (PUs) are those units that are engineered into the switching module to meet the needs of the customers. Optional PUs include:

- Line Unit 3 (LU3) - provides the termination of up to 640 analog lines capable of providing 4:1, 6:1, 8:1 and 10:1 line concentration.
- Digital Network Unit - Sonet (DNU-S) - provides termination of trunks.
- Digital Service Unit 3 (DSU3) - provides Recorded Announcement Functions (RAF), Integrated Services Test Functions (ISTF), and Voice Path Assurance (VPA).
- Digital Line and Trunk Unit 2 (DLTU2) - provides termination for T1 digital trunk facilities.
- Modular Metallic Service Unit (MMSU) - provides access to perform metallic testing of lines and trunks and provides miscellaneous scan and distribute points.
- Global Digital Service Function (GDSP) - provides transmission test functions and conference circuits.
- Integrated Digital Carrier Unit (IDCU) - provides termination of the following Digital Service (DS) facilities:
 - TR08 *SLC*® 96 *SLC* Series 5 FPB *SLC* Access System
 - TR303 *SLC* Series 5 FP303 *SLC* Access System Release 4 (Nov 94)
 - PUB43801 D4/D5 DACS II

- Packet Switching Unit 2 (PSU2) provides SS7 capabilities.
- Integrated Services Digital Network (ISDN)
 - Integrated Services Line Unit 2 (ISLU2) provides 512 terminations for a combination of digital and analog lines.
 - PSU2 provides packet switching functions.
 - SIP signaling is now supported on the PSU2 peripheral, and IP bearer for packet trunking is supported on OFI-IPs on the OIU peripheral.
 - Remote Integrated Services Line Unit (RISLU) provides ISDN services to customers beyond maximum ISLU2 loop boundaries.
- Access Interface Unit (AIU), Enhanced AIU (EAIU) and Multiplex Access Interface Units (XAIUs) provides the termination of analog customer lines.

2.5 Alarms

2.5.1 Alarm Status Unit (ASU)

The optional Alarm Status Unit (ASU) provides local audible and visual indication of the office alarms with LEDs for the alarm levels critical, major, and minor. There is an Alarm Retire key at the ASU which retires the audible alarms and clears the alarm level LEDs at the ASU. The local ASU is optional but the alarms are always remoted to the ASM. See 235-200-145, *5ESS Switch OneLink Manager Administrative Services Module (ASM) User's Guide*, for more information on alarms.

2.6 Capacities

The DRM can be engineered in terms of line capacity, trunk capacity, and applications/features. The line capacity of the DRM is a maximum of 28,800 lines or 24,000 trunks.

2.6.1 Switching Modules

The DRM supports one SM-2000.

2.6.2 Lines and Trunks

The line and trunk capacities of a DRM vary based upon:

- Line to trunk ratio
- Line concentration
- Features.

This list is not all inclusive. For additional details see 235-070-100, *5ESS Switch Administration and Engineering Guidelines*.

2.7 The DRM Network

2.7.1 Introduction

The DRM network provides an out-of-band data network infrastructure that supports centralized OAM&P (Operational, Administrative, Maintenance, and Provisioning) functions as well as connectivity to Operational Support Systems (OSSs), such as billing, surveillance, and traffic measurement. Although a customer may provide their own network solution, this section describes the connectivity, both Wide and Local Area Network (WAN and LAN) specification for both DRM central (host) and remote sites using the Lucent Technologies Components Solution (LNCS).

The ASM and 5ESS switch are located at the host site, and the DRM and AW are located at the remote sites.

2.7.2 Network Requirements

The host, remote, and the OSS sites all require network connectivity equipment supporting the following network protocols:

- WAN connectivity
- ISDN
- *Ethernet/Fast Ethernet*
- Asynchronous/Synchronous connectivity
- x.25, Internet Protocol (IP)
- Standard IP routing protocol(s)
- Protocol translation/conversion (XOT).

In addition, NEBS Level 3/ETSI compliance is recommended for all data network equipment.

2.7.3 Functions

The DRM network consists of components that connect the ASM at the host site to the DRM sites. This data network can be provided by Lucent Technologies, Inc., or supplied by the customer. See Figure 2-9 for the Lucent Network Components Solution (LNCS).

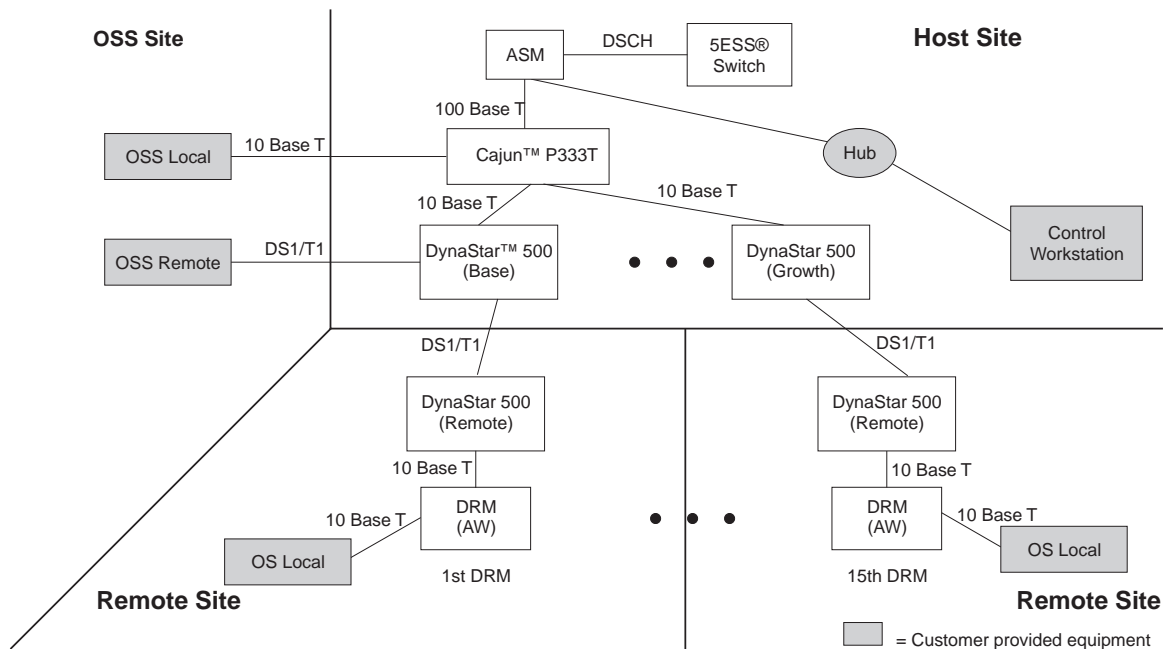

Figure 2-9 — The Lucent Network Component Solution (LNCS) Architecture

The hardware components used in the Lucent Technologies Network Solution consist of:

- **Cajun⁶ P333T Ethernet Switch** — a smart *Ethernet* switch
- **DynaStar 500⁷** — up to three routers at the host site, remote, and OSS sites.

2.7.3.1 Lucent Technologies Network Solution Documentation

Lucent Technologies Network Solution documentation referenced in this document include:

- Avaya Cajun P333T Stackable Switch User's Guide. For the latest copy go to <http://support.avaya.com/elmodocs2/p330/P333T/p333t33ug.pdf>
- *Dynastar 100/100i/100e/500⁸* Multi-Service Switches Installation And User Guide

For latest copy go to www.dynastarcom.com.

2.7.3.2 Component Functions

Each hardware component provides a unique function to the DRM Network.

2.7.3.2.1 The Smart *Ethernet* Switch

Unlike a hub, which is a passive device that broadcasts signals it receives to all other devices connected to it, the smart ethernet switch routes data it receives only to the correct destination.

In the LNCS, the *Cajun* P333T is the smart *ethernet* switch, and as such it:

- converts 100BaseT protocol to 10BaseT protocol
- allows multiple routers to interface with the single port on the QFE card installed in the ASM.

2.7.3.2.2 The Routers

In the LNCS, there are two router options: A and C. Each has its own purpose.

Router option A is used in the LNCS to:

- supply up to 6 DS1s for routing data signals.
One DS1 is dedicated to a connection to operating systems used for billing, network management, and traffic measurement. The remaining 5 DS1s are connected to DRM sites. Each DRM site is engineered with a DS1, therefore, up to 5 DRM sites may be connected to the first router.

The second and third routers installed are option C routers. These routers can supply up to 6 DS1s for connection to DRM sites.

Each DRM site, has one option C router. This router converts between DS1 format and 10 BaseT. The 10 BaseT connects to the rear of the Administrative Workstation (AW). Port 0 on a Quad Fast *Ethernet* card provides the interface for a *Netra* t 1120 or *Netra* 20. The onboard *Broadcom Gigabit Ethernet* port 2 provides the interface for a

6. Trademark of Avaya Communications.

7. Trademark of DYMEC, Inc.

8. Trademark of DYMEC, Inc.

Netra 240. The DS1s are transported using a Primary Rate Interface (PRI) ISDN connection. If the PRI is lost, a backup Basic Rate Interface (BRI) carries the data until the PRI is restored.

2.7.3.3 Hardware

The DRM network requires two distinct hardware configurations at the two types of sites:

- the host site
- the remote DRM sites (up to 15)

2.7.3.3.1 Hardware Components at the Host Site

At the host site, the networking equipment can be installed in the same miscellaneous cabinet as the ASM. The Smart *Ethernet* Switch is a *Cajun P333T*. The routers are *DynaStar*⁹ 500s. See Figure 2-10 for the configuration of the Lucent NCS. Router 00 is option A, and Routers 01 and 02 are option C.

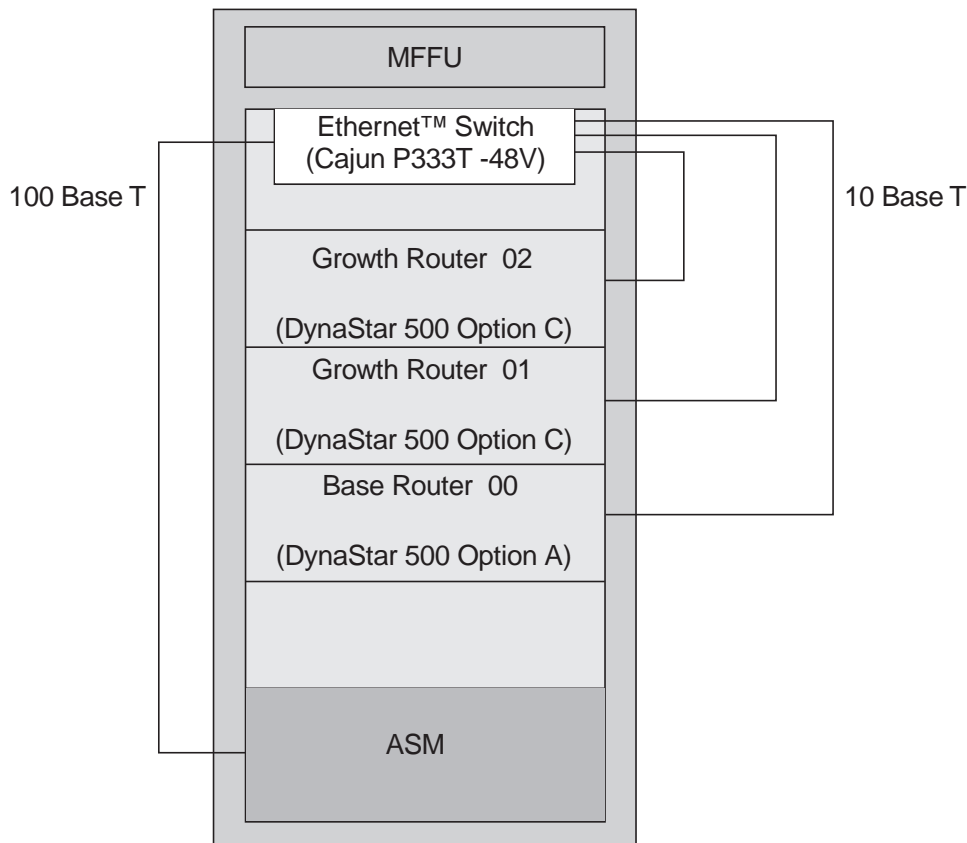

Figure 2-10 — Host Site Hardware Components

9. Trademark of DYMEC, Inc.

2.7.3.3.2 Hardware Components at the DRM Site

At the DRM site, the AW is mounted in a miscellaneous cabinet. The DRM patch panels and the high speed interfaces are mounted in a metal panel. Splitters, which allow connections for the Remote MCC and Remote Console are mounted in a separate metal panel. The *DynaStar* Option C is mounted in the same cabinet. See Figure 2-11 for the DRM Site hardware of the Lucent NCS.

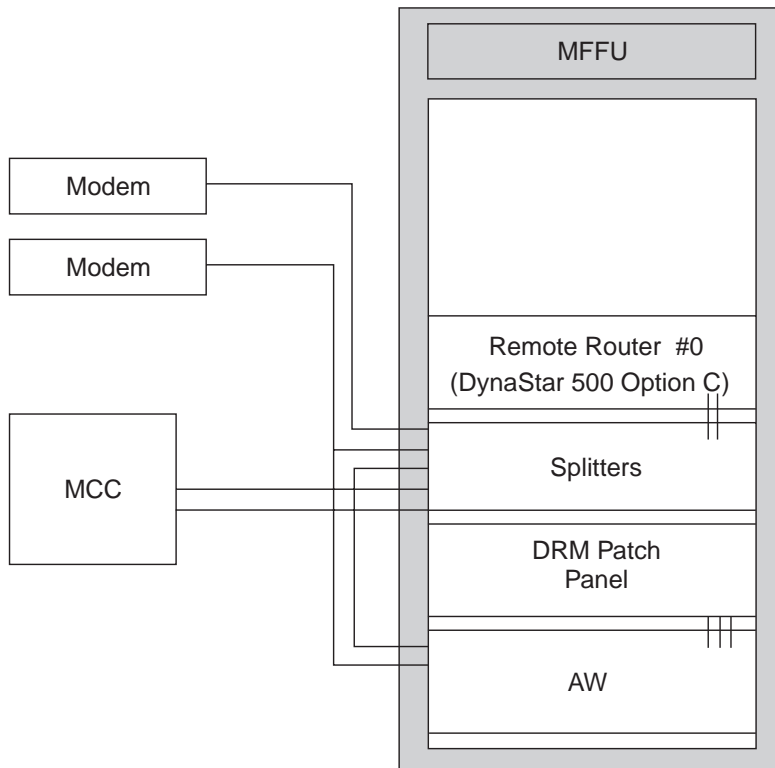

Figure 2-11 — DRM Site Hardware Components

2.7.4 The Operational Support (OSS) Systems

Different operational support systems (OSSs) perform various support functions and are connected to the network in the different locations shown in Figure 2-12 .

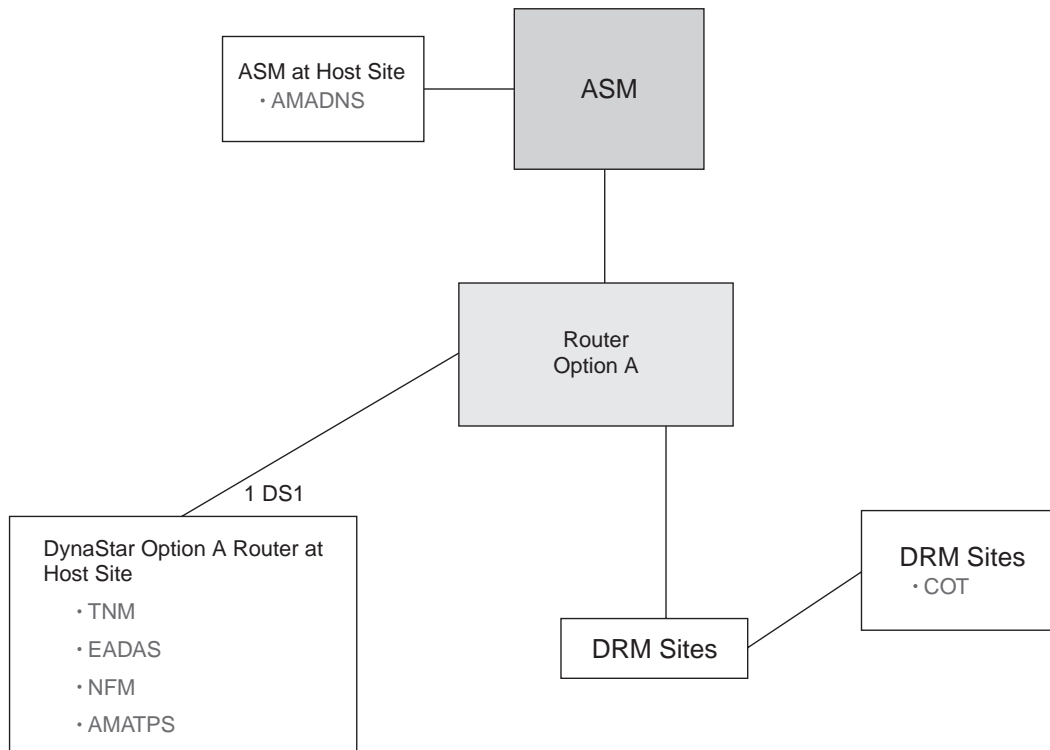

Figure 2-12 — Operational Support Systems

The following Operating Systems support the DRM at either the host and remote sites:

- **TNM** — Total Network Management performs surveillance
- **EADAS** — Engineering and Administrative Data Acquisition System performs traffic analysis
- **NFM** — Network Fault Management
- **AMATPS** — AMA Teleprocessing (billing)
- **AMADNS** — Automatic Messaging Account Data Networking System (TCP/IP billing)
- **COT** — Customer Originated Trace (modem connection to local law enforcement agency)

2.7.5 Network Component Maintenance Screens

The *Cajun* Smart *Ethernet* switch can be accessed by connecting a PC to the console port. The *DynaStar 500* routers can be accessed through three different methods:

- connecting a laptop computer to port 6
 - Note:** After initial configuration, the *DynaStar 500* can use port 6 for other operations.
- a dial-up connection
- anywhere on the LAN to which the *DynaStar 500* is connected.

2.8 Optional Local Terminal Interfaces

This section identifies and describes the various Input/Output (I/O) interfaces that are optional for the DRM. These interfaces allow administrative and maintenance personnel and Operational Support Systems (OSSs) to communicate with the DRM from the DRM office. This section also describes the functions provided by the I/O facilities to assist the switch administrator.

Terminal devices are used by maintenance and administrative personnel for typing input messages and displaying both input and output messages. Examples of terminal devices are teletypewriters, cathode ray tube (CRT) terminals, and a Receive-Only Printer (ROP). Data link interfaces are also provided to Operational Support Systems (OSSs) for additional administrative and/or maintenance support as needed.

Further information concerning the operations and functions provided by these interface facilities is provided in 235-190-1XX series of feature description documents.

Terminal devices are connected to the AW using the interface provided by the Serial Asynchronous Interface (SAI) card. The AW serial interface is shown in Figures 2-13 , 2-14 and 2-15.

It is recommended that MCC, ROP, and STLWS access is present at the DRM.

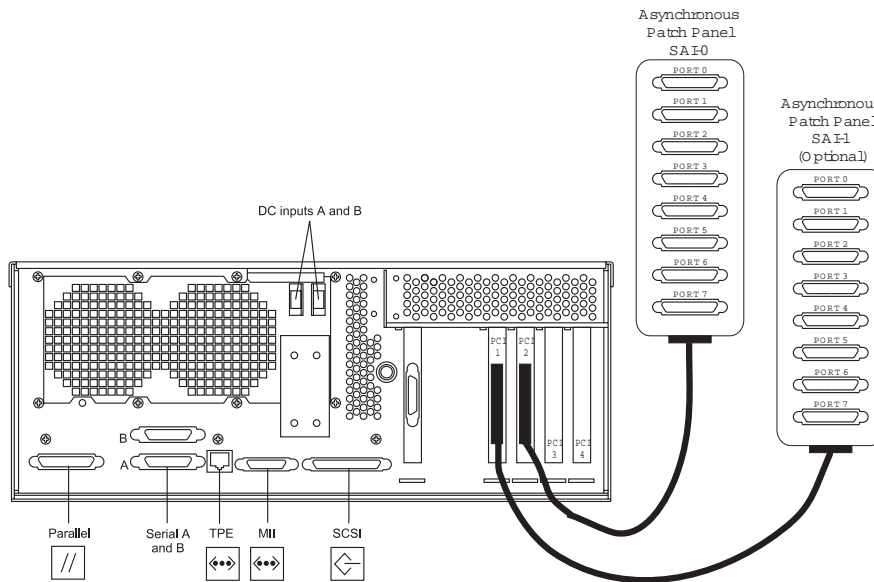

Figure 2-13 — Administrative Workstation Terminal Interface Connections (Netra t 1120)

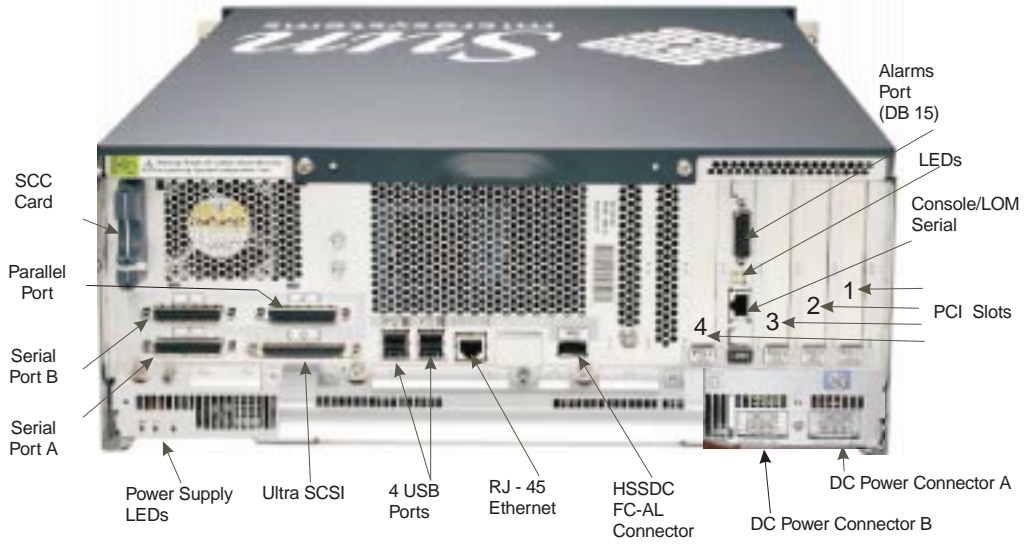

Figure 2-14 — Administrative Workstation Terminal Interface Connections (*Netra 20*)

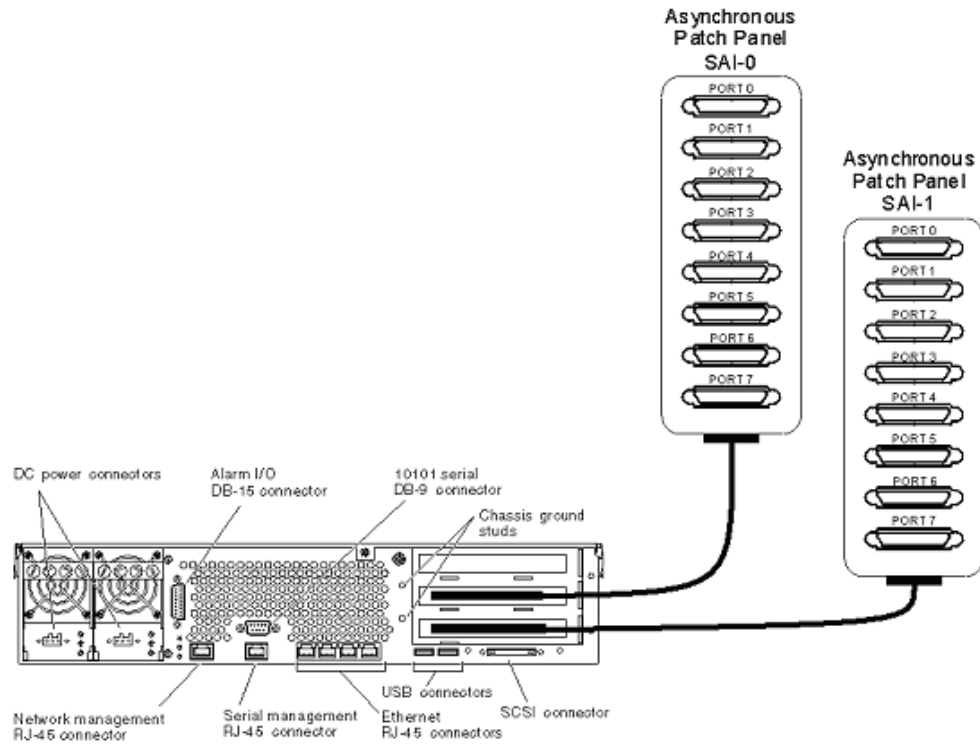

Figure 2-15 — Administrative Workstation Terminal Interface Connections (*Netra 240*)

2.9 Types of Terminal Interfaces and Operating Support Systems

This section will cover the following interfaces:

- Serial Interface
- High-Speed Interface
- *Ethernet* Interface
- Master Control Center (MCC)
- Receive-Only Printer (ROP)
- Supplemental Trunk Line Work Station (STLWS)
- Recent Change and Verify (RC/V)
- Automatic Message Accounting (AMA) Data Link
- SCANS Data Link.
- SCCS Data Link.

Refer to the documents listed in Table 2-4 for information about additional terminal interfaces available at the DRM.

Table 2-4 — Terminal Interface Devices

Name	Description	Document
TRAFFPRT	Local Traffic Measurements Channel	235-070-100A1 235-105-231
OFFRECRPT	On-line Office Record Print Channel is used to print office record forms.	235-118-2XX 235-900-304
CALEASAS	Electronic Surveillance Terminal	235-200-400 235-200-410
CALEAPRT	Electronic Surveillance Printer	235-200-400 235-200-410

2.9.1 Serial Interface

The DRM uses a serial adapter card to interface multiple serial devices such as terminals and printers to the AW.

The serial card is equipped in the AW as follows:

- PCI slots (*Netra* 240) – PCI slot 1 is equipped with a Serial Asynchronous Interface (SAI) card that provides 8 serial ports for terminal and printer connections. PCI slot 0 is equipped with a second SAI card that supports 8 terminal and printer connections.
- PCI slots (*Netra* 1120 and *Netra* 20) – PCI slot 2 is equipped with a Serial Asynchronous Interface (SAI) card that provides 8 serial ports for terminal and printer connections. PCI slot 1 can be equipped with an optional second SAI card that supports 8 terminal and printer connections.

Figures 2-16, 2-17 and 2-18 provide illustrations of a Supplemental Trunk Line Workstation (STLWS) and ROP connected to the AW system unit. While these figures show the STLWS attached to a specific port, a terminal device can occupy any available *non-reserved* port. Tables 2-5 and 2-2 list the serial port assignments for terminal devices.

Table 2-5 — Netra t 1120 and Netra 20 Terminal Port Assignments

AW PCI SLOT No.	SAI PORT	Terminal Device
2	0	Reserved (CPI Side 0)
2	1	Reserved (CPI Side 1)
2	2	Note ^a
2	3	Note ^a
2	4	Note ^a
2	5	Note ^a
2	6	Note ^a
2	7	Note ^a
1	0	Note ^a
1	1	Note ^a
1	2	Note ^a
1	3	Note ^a
1	4	Note ^a
1	5	Note ^a
1	6	Note ^a
1	7	Note ^a

Note(s):

a. Terminal devices can be STLWS, RC/V, Traffic Printer, or Office Record Printer.

Note: The Receive-Only Printer (ROP) is connected to the parallel port on rear of workstation.

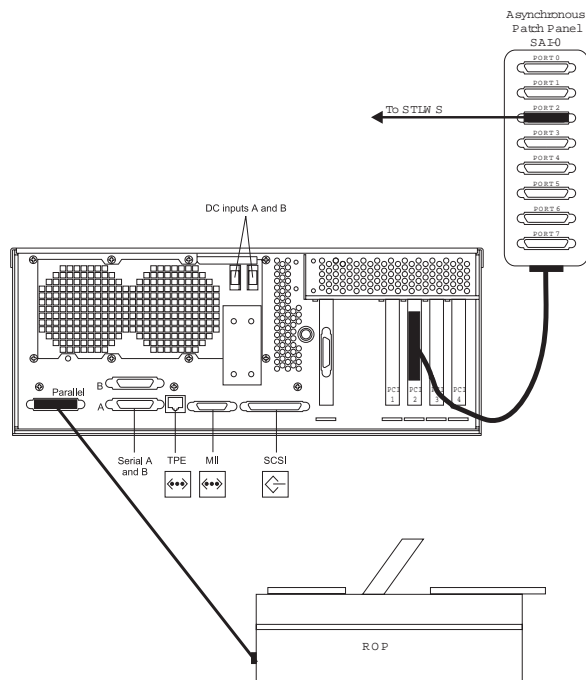

Figure 2-16 — Serial Asynchronous Interface (SAI) for Netra t 1120

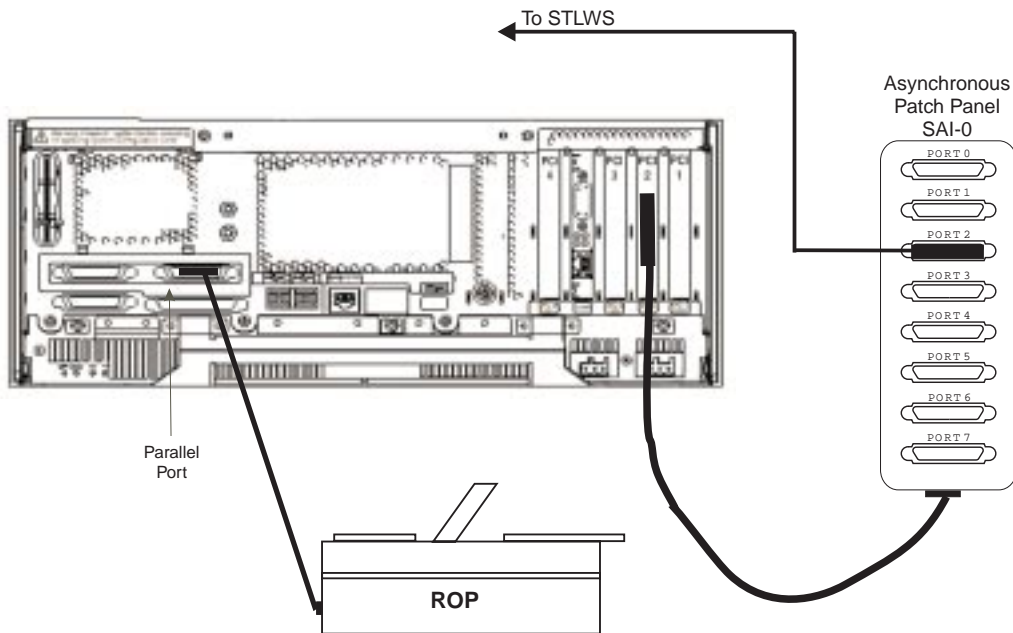

Figure 2-17 — Serial Asynchronous Interface (SAI) for *Netra 20*

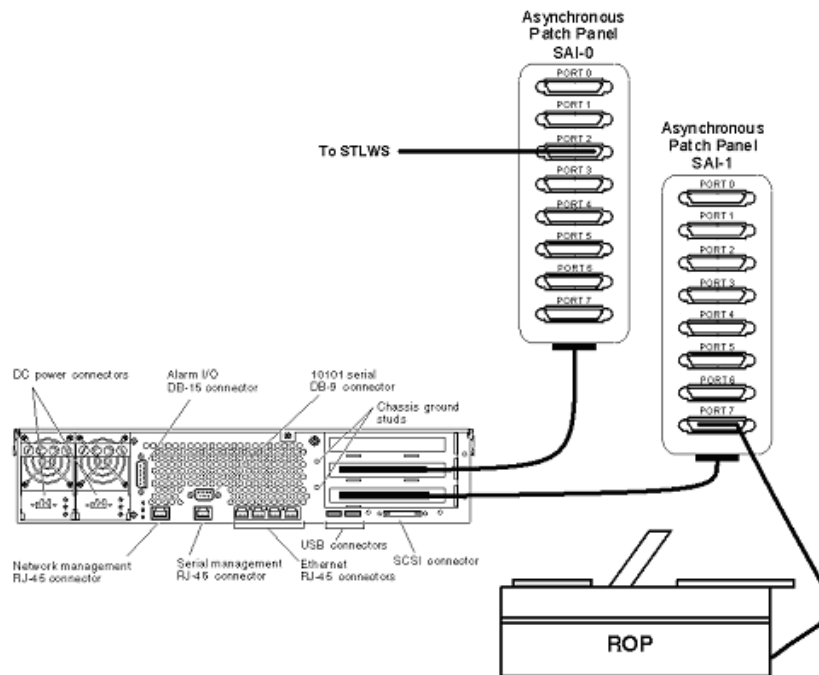

Figure 2-18 — Serial Asynchronous Interface (SAI) for *Netra 240*

2.9.2 High-Speed Interface

A High-Speed Interface (HSI) Controller is used to connect certain high speed terminal devices to the AW.

The high-speed interface card is equipped in the AW as follows:

- PCI slots (*Netra* 240) – PCI slot 2 is equipped with a High Speed Interface (HSI) card that provides 4 ports for data link connections.
- PCI slots (*Netra* t 1120 and *Netra* 20) – PCI slot 3 is equipped with a High Speed Interface (HSI) card that provides 4 ports for data link connections.

Figure 2-19, 2-20 and 2-21 provide illustrations of the HSI Controller High-Speed Interface and its connection to the AW. Table 2-6 lists terminal devices that can be interfaced using this controller.

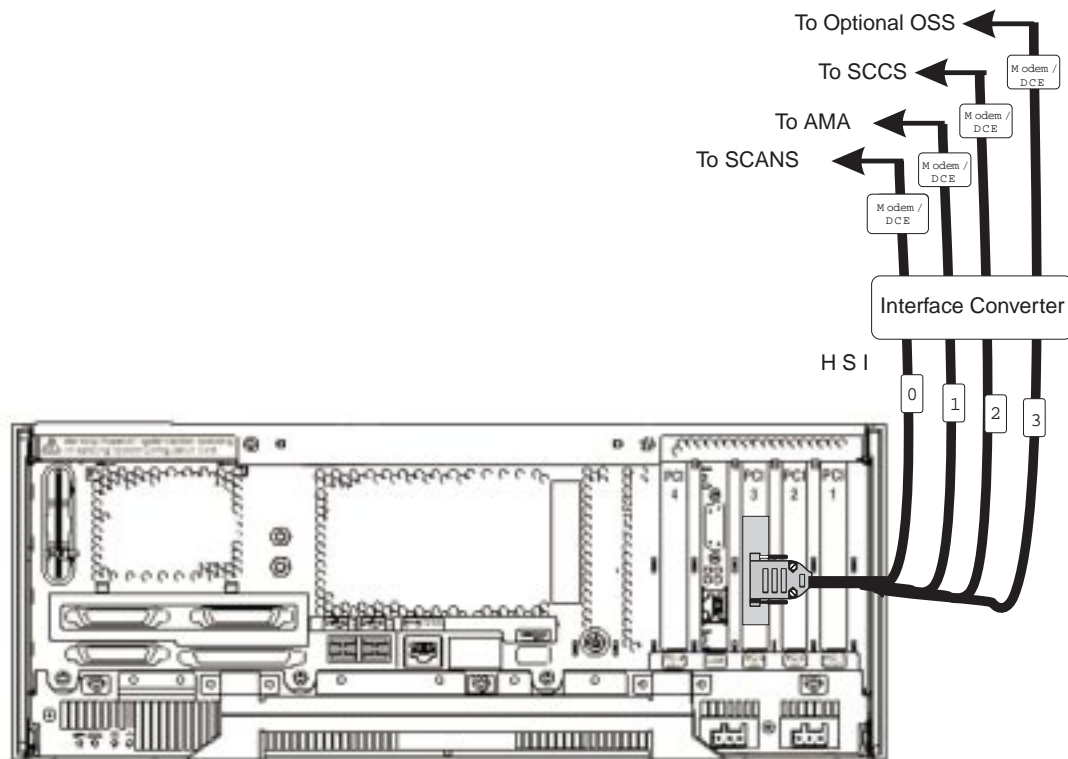

Figure 2-19 — NETRA t 1120 Workstation High-Speed Interface to AW Connections

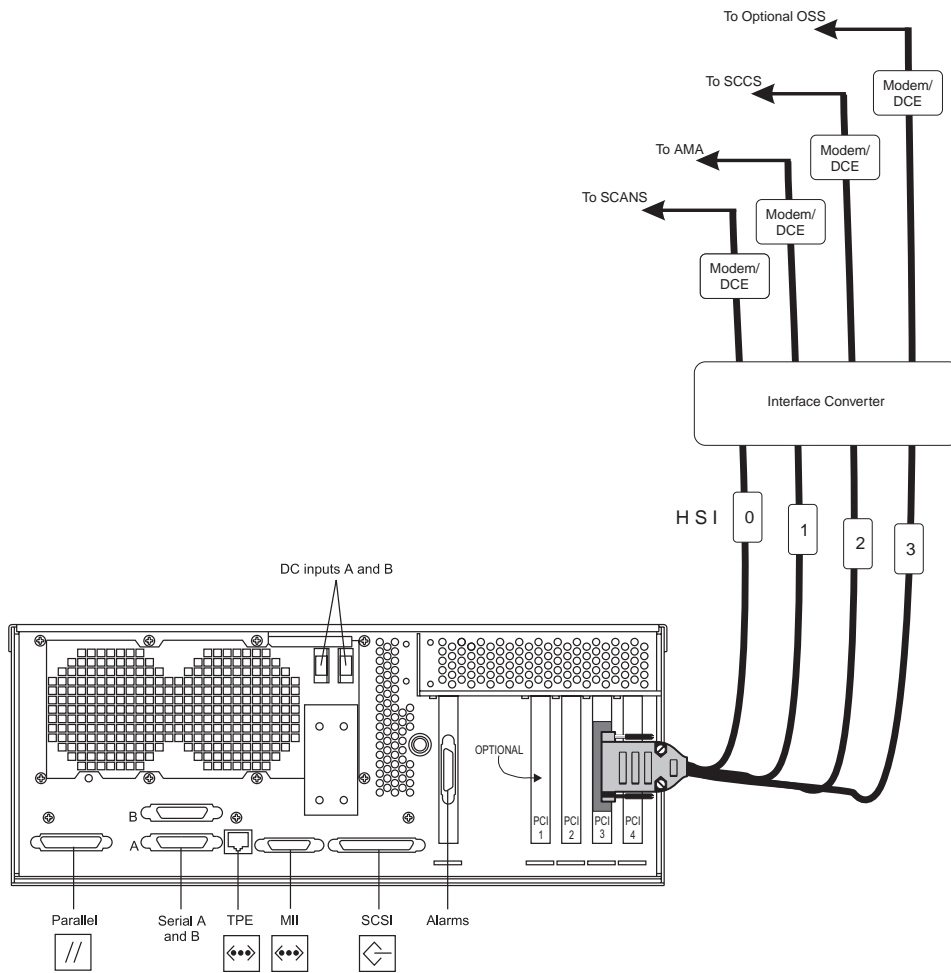

Figure 2-20 — NETRA 20 Workstation High-Speed Interface to AW Connections

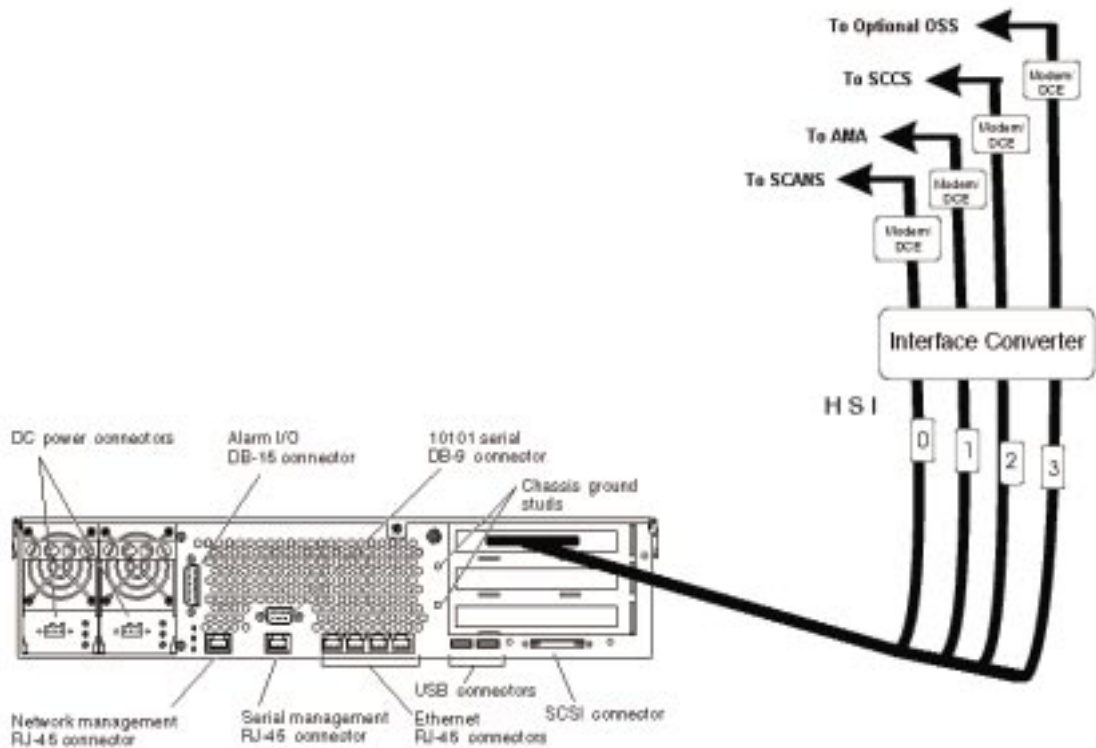

Figure 2-21 — NETRA 240 Workstation High-Speed Interface to AW Connections

Table 2-6 — High-Speed Port Assignment

Controller Port	Terminal Device
0	SCANS Data Link
1	AMA Data Link
2	SCC Data Link
3	EADAS Data Link

2.9.3 Quad Fast Ethernet (QFE) Interface (Netra t 1120 and Netra 20)

The QFE card is used to interface up to four Ethernet networks. Figures 2-22 and 2-23 illustrate the connections to the AW. Table 2-7 lists Ethernet networks that can be interfaced using the QFE card.

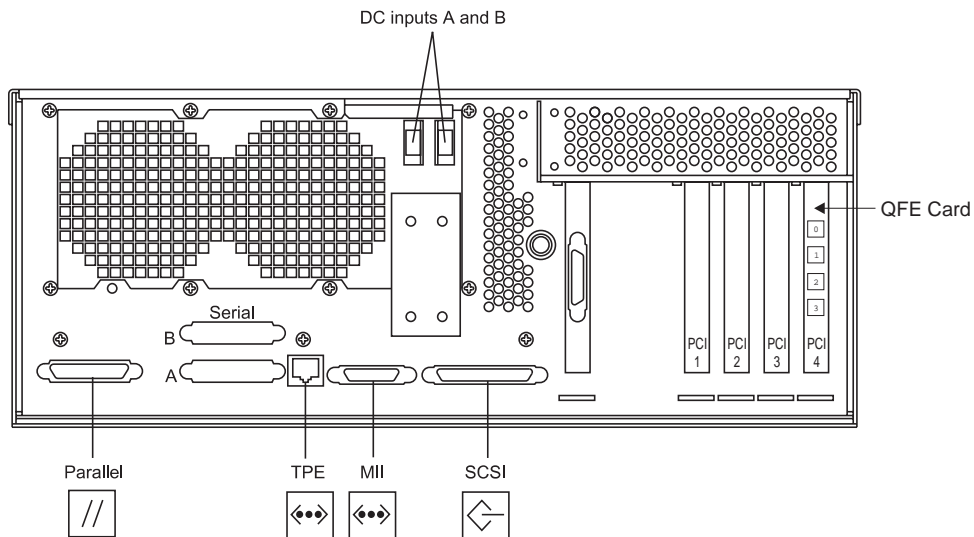

Figure 2-22 — Quad Fast Ethernet - Netra t 1120 Interface Connections

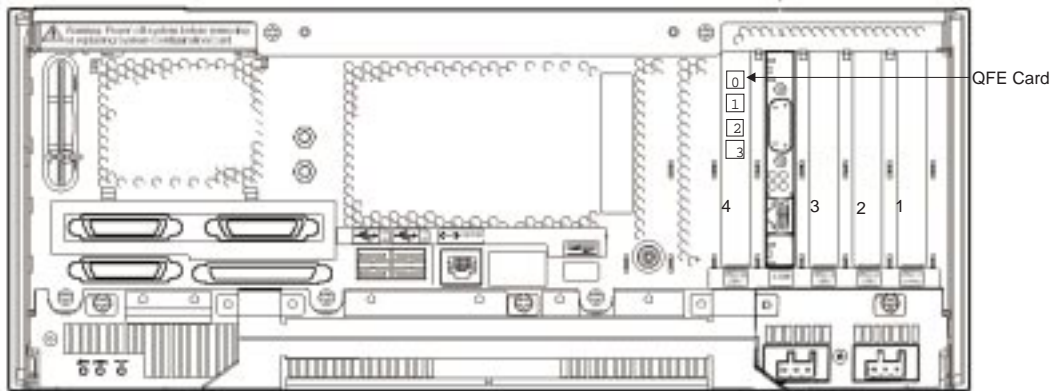

Figure 2-23 — Quad Fast *Ethernet* - *Netra 20* Interface Connections

Table 2-7 — QFE Port Assignment

QFE Port	<i>Ethernet</i> Networks
0	ASM
1	Not assigned
2	Not assigned
3	Not assigned

2.9.4 *Broadcom Gigabit Ethernet*(BGE) Interface (*Netra 240*)

The onboard BGE ports are used to interface up to four *Ethernet* networks. Figure 2-24 illustrates the connections to the AW. Table 2-8 lists *Ethernet* networks that are interfaced using the BGE ports.

Figure 2-24 — *Broadcom Gigabit Ethernet* — *Netra 240* Interface Connections

Table 2-8 — BGE Port Assignments

BGE Port	Ethernet Networks
0	SM
1	Not assigned
2	ASM
3	Not assigned

2.9.5 Master Control Center (MCC)

The Master Control Center (MCC) is the primary communication link between on site maintenance personnel and the DRM. A dual ported terminal is used to connect the *Solaris* Console to the A serial port and the MCC to the B serial port on the rear of the *Netra t 1120* and *Netra 20 AW*. For a *Netra 240 AW*, the *Solaris* Console is connected to the DB-9 serial port on the rear of the AW and the MCC is connected to serial port 6 on SAI-1.

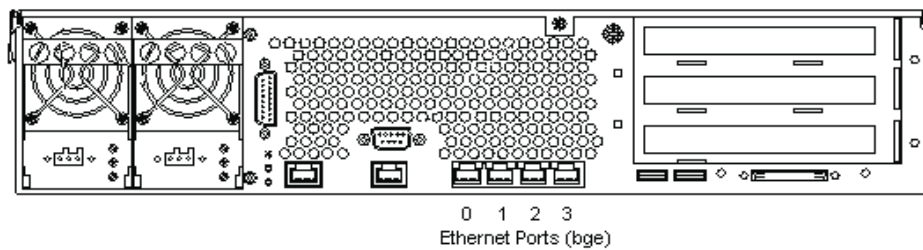
Figures 2-25, 2-26 and 2-27 illustrate the MCC and *Solaris* Console cable connections for the KS-22396 terminal.

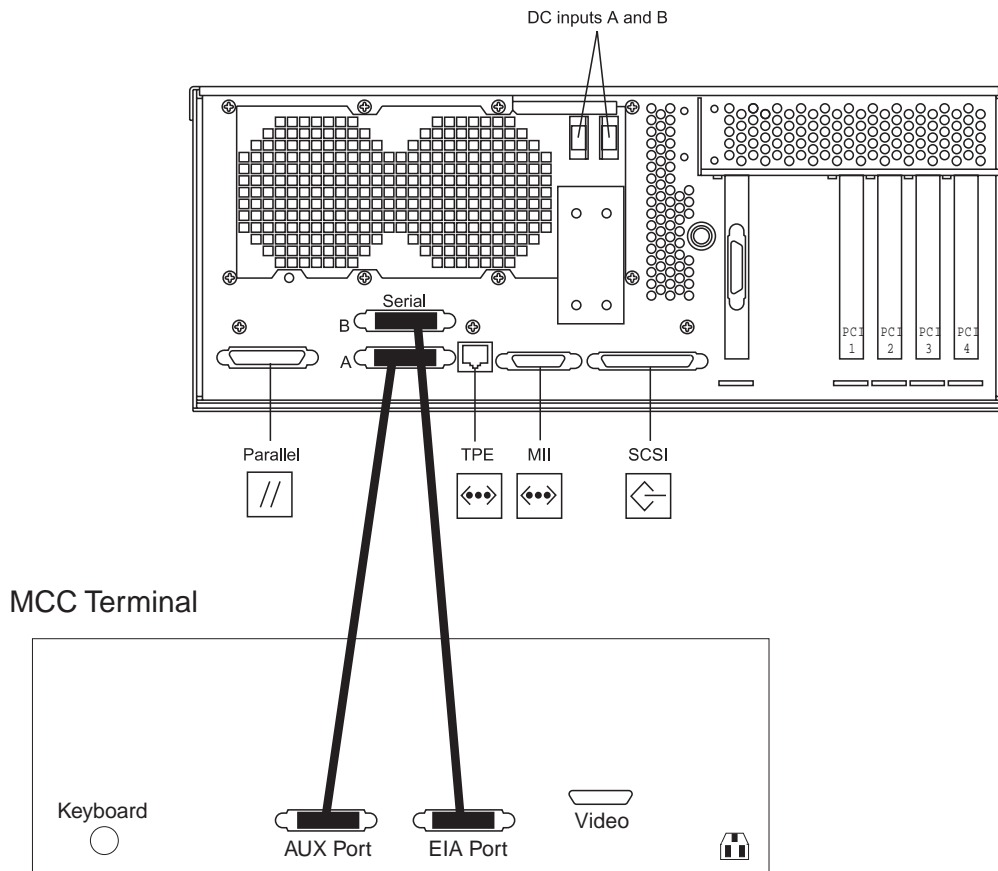

Figure 2-25 — KS-22396 MCC Interface to Administrative Workstation - *Netra t 1120*

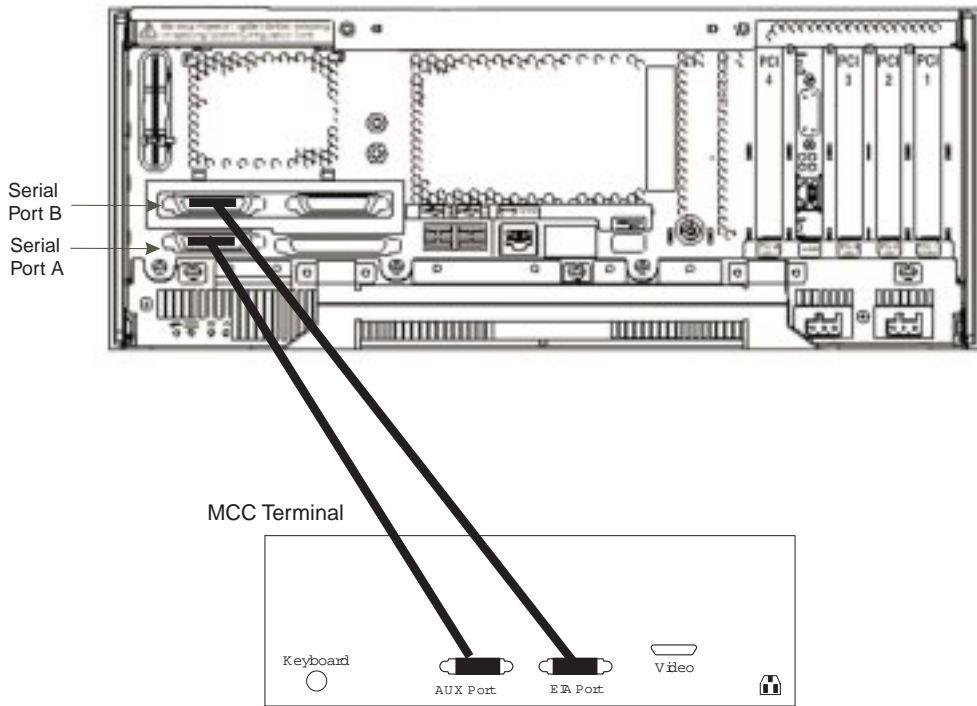

Figure 2-26 — KS-22396 MCC Interface to Administrative Workstation - *Netra 20*

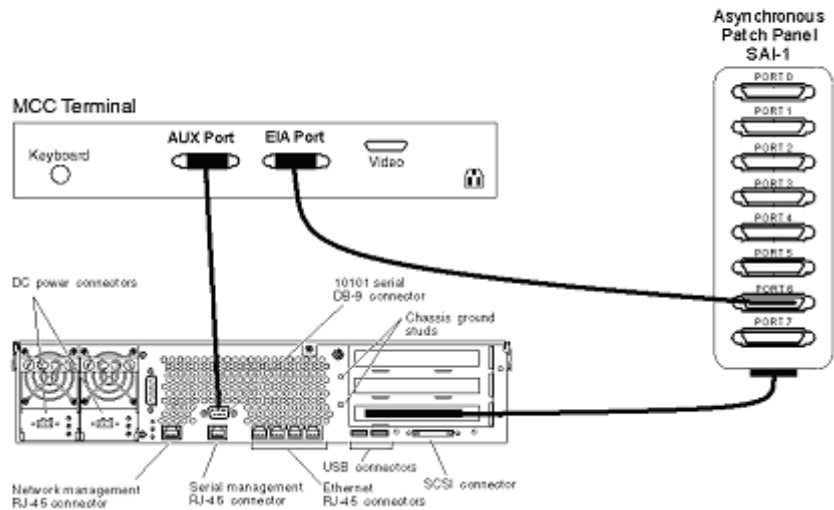

Figure 2-27 — KS-22396 MCC Interface to Administrative Workstation - *Netra 240*

Figures 2-28, 2-29 and 2-30 illustrate the MCC and *Solaris* Console cable connections for the KS-24697 terminal.

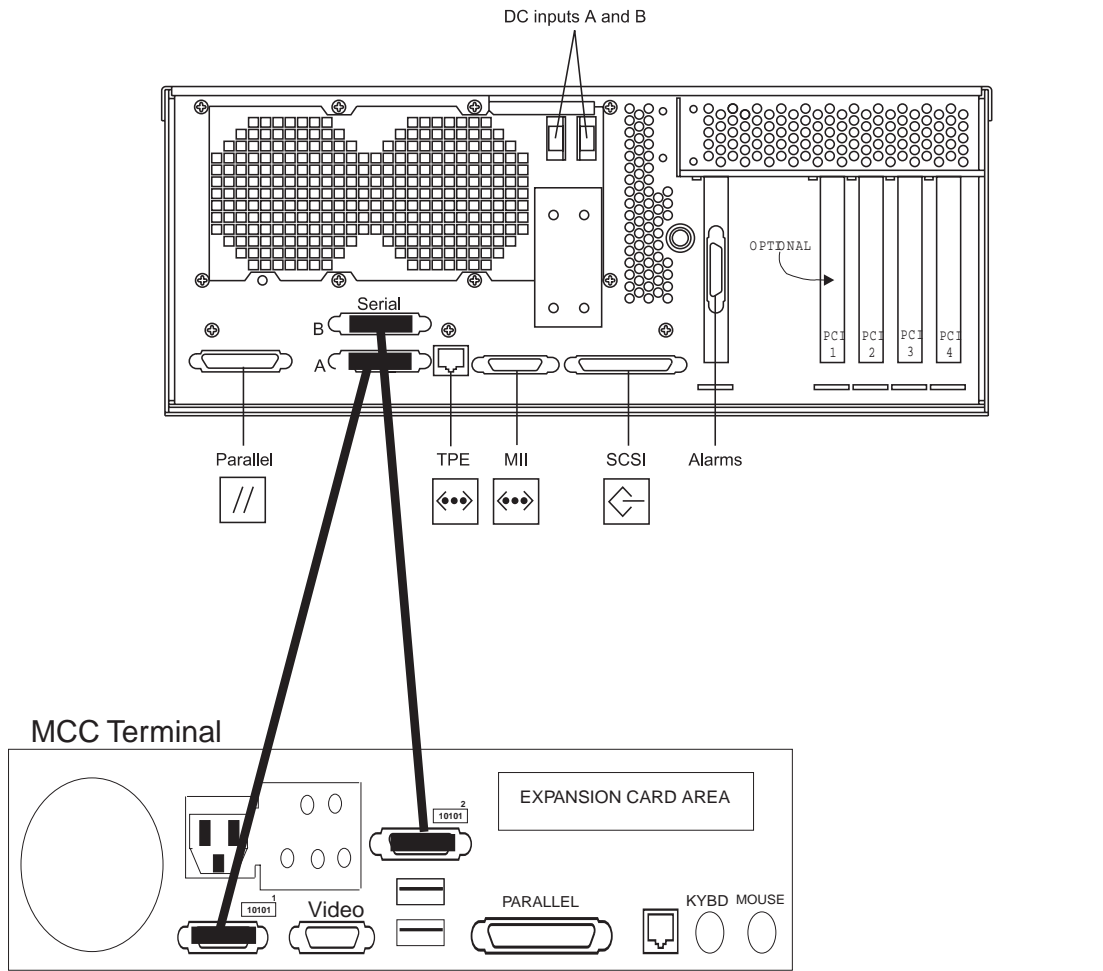

Figure 2-28 — KS-24697 MCC Interface to Administrative Workstation (NETRA t 1120)

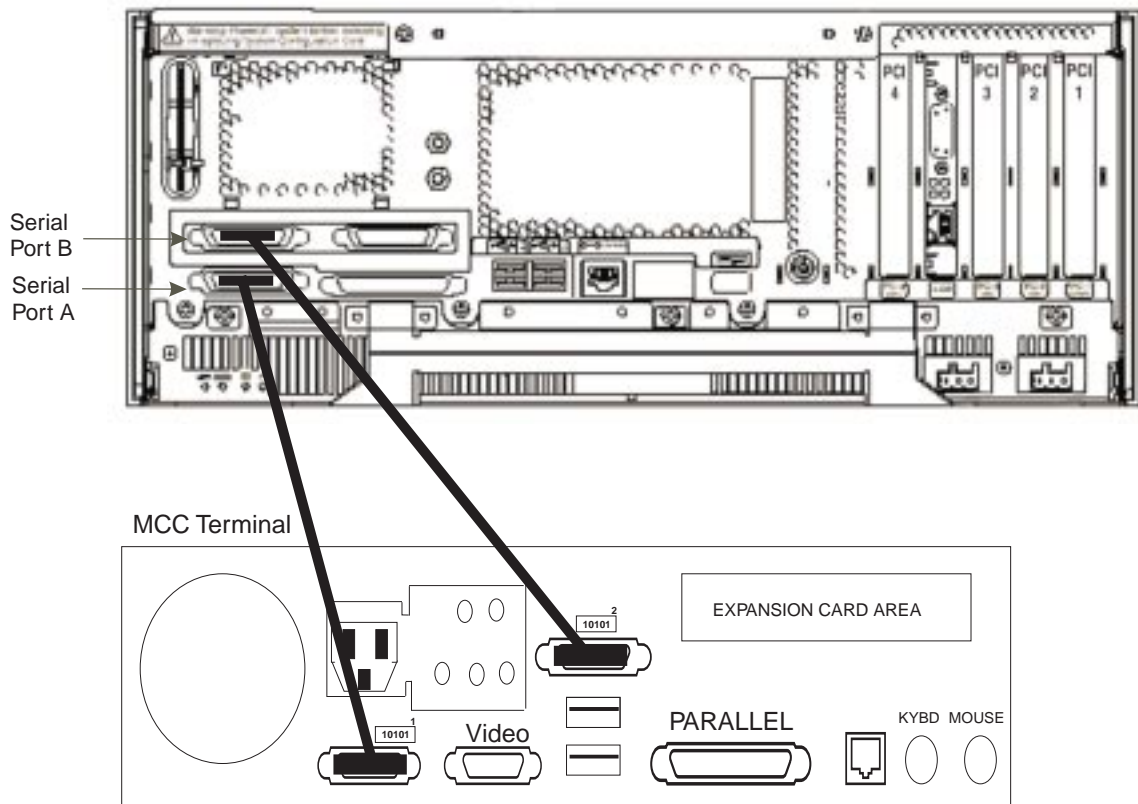

Figure 2-29 — KS-24697 MCC Interface to Administrative Workstation (NETRA 20)

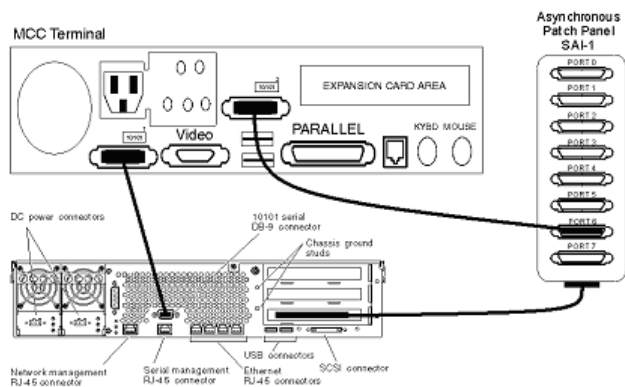

Figure 2-30 — KS-24697 MCC Interface to Administrative Workstation (NETRA 240)

The MCC provides maintenance personnel with real-time system status indications, control and display capabilities, and input/output messages. Refer to Figure 2-31. The MCC also provides manual emergency recovery capabilities, Recent Change functions, and the ability to request reports. The major components of the MCC consist of the following:

- Video Display Terminal (VDT)
 - The VDT display pages provide the status and control information needed to perform maintenance tasks. Maintenance requests are input using a keyboard. The terminal is also used to access *Solaris UNIX*¹⁰.
- Receive-Only Printer (ROP)
 - The ROP provides a hardcopy of input and output messages, creating a record for future reference. Traffic measurement data can also be directed to the ROP.

2.9.5.1 Video Display

The optional local MCC video display terminal provides office maintenance personnel with a means to interface with the DRM for system status indications, configuration controls, and human-machine interface messages. The MCC video display terminal is not duplicated. For functional purposes, the video display terminal is divided into the following units:

- Display
- Alphanumeric keyboard
- Numeric/function keypad.

The MCC (MTTY or MCRT) provides a split-screen effect (see Figure 2-31). The video display has a general layout that consists of an identification line, a system summary area, a control and display page area, and an input message entry area.

10. Registered trademark in the United States and other countries licensed exclusively through X/Open Company Limited

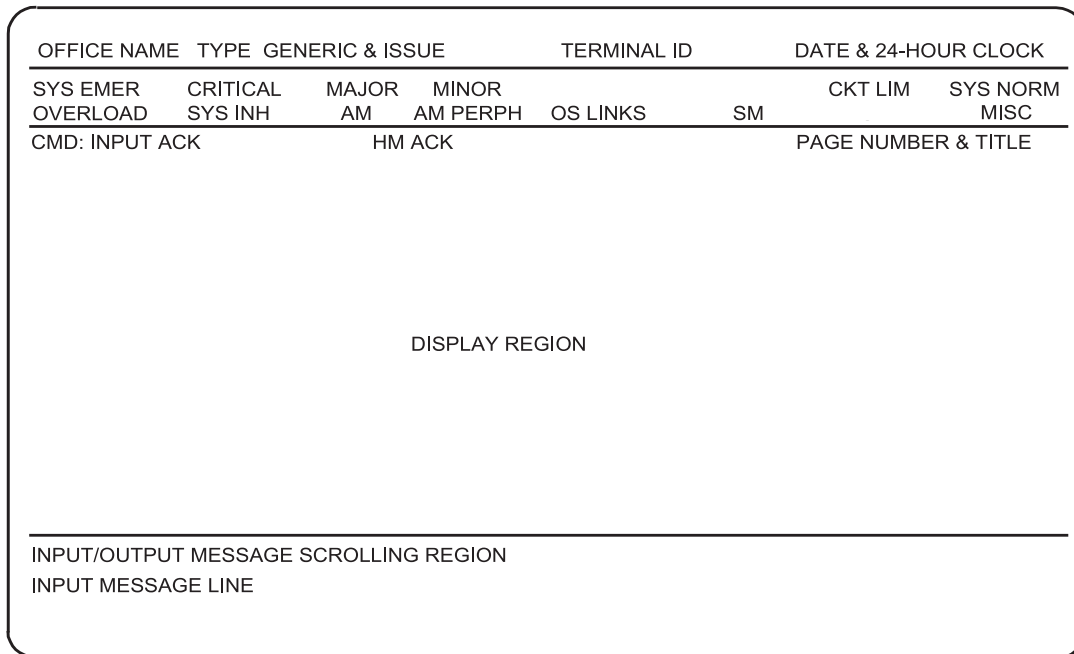

Figure 2-31 — MCC Page Display Design

The identification line is present at all times and displays the office name, system type, and the current date and time.

The system status display provides an indication of the overall status of the office. This includes:

- Individual unit status
- Abnormal load conditions
- Significant controls in effect
- Alarms and other abnormalities.

The various conditions are shown in distinctive graphics and type faces.

The color video display at the MCC uses a variety of colors to indicate the status of individual units in the DRM.

The control and display area is provided to give the maintenance personnel the interface necessary to operate and maintain the system. This area displays information pertinent to the office and provides the controls for maintaining and operating the system.

The various screen formats are referred to as control and display pages. Each control and display page shows the operating condition and possible input commands for each subsystem. An index page is provided to allow quick access to the display pages. A blank page is displayed whenever other control and display information is not required. For additional information on the MCC display pages, see 235-105-110, *5ESS Switch System Maintenance Requirements and Tools*. Figure 2-32 shows a typical MCC display page.

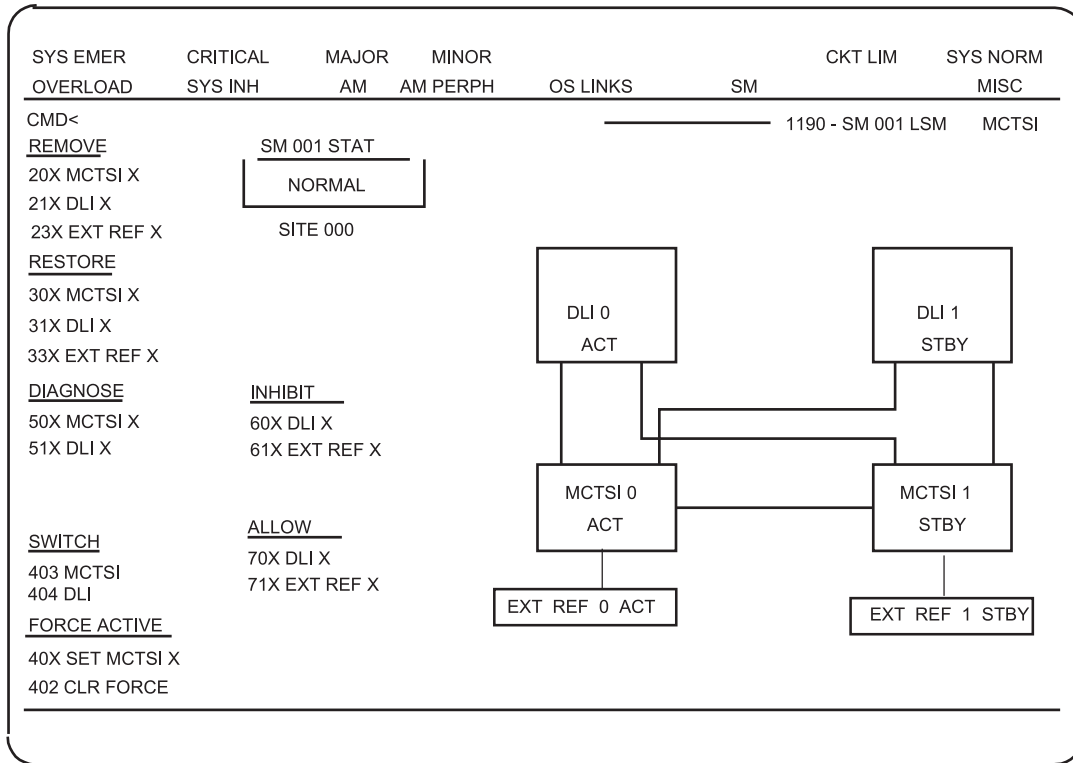

Figure 2-32 — Typical MCC Display Page

The bottom two lines of the video display are used for message entry. This area displays the input messages from the MCC keyboard.

2.9.5.2 Emergency Action Interface (EAI)

The primary function of the EAI is to provide manual recovery capabilities during periods of system emergency. This interface enables configuring a working system when normal recovery procedures prove inadequate. The emergency page has a menu of control and initialization functions that can be forced on the system. Figure 2-33 shows a typical EAI display page.

input command **INIT:SM=a,NOINIT;**. See 235-600-700, *Input Messages Manual*, for additional information on this command.

2.9.5.2.1 Emergency Action Interface (EAI) Validity

After requesting the emergency action display page by depressing the EMER DISP function key, the **video terminal digit indicator** must be checked to ensure a valid display. The video terminal indicator is located in the upper center portion of the display (Figure 2-33). The video terminal digit indicator consists of the maintenance teletypewriter (MTTY) or maintenance cathode ray tube/terminal (MCRT) followed by a numeric digit displayed in dynamic text. The digit is increased every 2 seconds. If this indicator is not displayed and is not increasing, the **entire** display is invalid.

Once the validity of the display is determined, other indicators are used to qualify EAI and emergency functions. Table 2-9 summarizes these indicators.

Note: The rest of the indicators on the display are valid only for EAIs indicating All Seems Well (**ASW**).

2.9.5.2.2 Emergency Action Interface Indicator Area

The EAI indicators reflect the progress of the emergency action. The emergency action is progressing successfully if the ASW indication is present (Figure 2-33).

The Control Unit (CU) status area is located at the upper left portion of the EAI page display (Figure 2-33). This area informs the maintenance personnel which of the CUs is active and which is on- or off-line. The term CU refers to the control unit or the AW.

At the upper right portion of the EAI page display is the Processor Recovery Message (PRM) area (Figure 2-33). The PRMs display the systems coded failure/success recovery information. The PRMs change continuously during an initialization, reflecting the current state.

Table 2-9 — Emergency Action Indications and Qualifiers

INDICATIONS	MEANING
<i>EAI INDICATIONS</i>	<i>MEANING WHEN DISPLAYED IN REVERSE VIDEO</i>
ASW	(1) 3B21 emulator is communicating with EAI. (2) EAI reports all seem well (ASW).
ERR	(1) 3B21 emulator is communicating with the EAI. (2) EAI reports internal EAI problem.
OOS	(1) 3B21 emulator is not communicating with the EAI. (2) Displayed EAI status is unreliable.
<i>CU INDICATIONS</i>	<i>MEANING WHEN DISPLAYED IN REVERSE VIDEO</i>
ACT	Control unit (CU) Software is on-line (active).
FONL	Emergency action has forced hardware on-line.
FOFL	Emergency action has forced hardware off-line.
RUN	CU is running under software release control.
RCVRY	CU has begun recovery.
SET	Associated function is set.
INH	Associated function is inhibited.
<i>PRM DIGITS</i>	<i>MEANING OF THE DIGITS</i>
rrrr rrrr rrrr rrrr	Indicates the Processor Recovery Message (PRM).
ss ss	Indicates the emergency action status at the time the PRM was received.
nn	Indicates the low-priority PRM state at the time the PRM was received.
<i>PRM TEXT DISPLAYED</i>	<i>MEANING WHEN IN PARTICULAR TEXT</i>
rrrr rrrr rrrr rrrr ss ss nn (bold reverse video)	Trapped failure PRM.
rrrr rrrr rrrr rrrr ss ss nn (dynamic text)	Last PRM received from the EAI.

2.9.5.2.3 Emergency Action Interface (EAI) Menu

Emergency functions are entered by typing the appropriate 2-digit command code and executing it. Table 2-10 provides a list of the EAI commands with a description of

their actions. For more details of how to use these functions, refer to 235-105-250, *5ESS Switch System Recovery*. The carriage return is used to execute emergency functions.

The menu commands can be grouped into the following categories:

- **Commands 14 and 15:** These commands have a direct and immediate effect on the system. Some commands force the AM into a particular configuration and some release a forced configuration.
- **Commands 20 through 43:** These commands are preparation commands that specify certain conditions prior to a system initialization. These conditions do not take effect until an initialization command is given.
- **Commands 50 through 58:** These are the initialization commands. These commands cause the conditions that were specified previously with commands 20 through 43 to take effect.
- **Command 59:** This command stops the 3B21 emulator, thus stopping the AM.

Note: This command should NOT be executed unless under the direction of Customer Technical Support.

The severity of the initialization increases with the command number (command 54 has the greatest impact). The system can automatically trigger commands 50 through 53 during an initialization.

Command 54 can only be triggered manually and causes an AM initialization. This takes these processors completely off-line.

Command 55 is normally required during the initial installation interval or when an initialization from tape is required due to a massive corruption of disk data. During this tape load, the system is off-line and call processing is disabled for a considerable period of time.

The 51 through 58 commands when entered on the command line cause the system to immediately enter an emergency action mode.

Once the emergency action has completed, the system is restored (automatically) to a stable state and call processing resumes. The EAI page display disappears and the MCC Page Display 111/112, AM Peripherals, is automatically displayed.

Caution: *Commands from the EAI page display should only be used under the direction of your technical assistance group. Improper use of the commands on the EAI page can have a very negative impact on the integrity of the system.*

Each command executed is acknowledged either **OK** or **NG**. This acknowledgment appears adjacent to the command entry area in the top left line of the display. After entering a command, the input and response are displayed until the next character is typed. Errors may be erased a character at a time by pressing the backspace key or by pressing **Ctrl h**.

Table 2-10 — Emergency Action Interface (EAI) Maintenance Commands

COMMAND	DESCRIPTION
14	Clears all of the following which may be in effect: forces on- or off-line, sets on primary or secondary disk and timer inhibits.
15	Used together with the application parameters (1, 2, or 3) to produce three levels of craft initialization.
20	Inhibits automatic processor recovery disk unit selection and forces both processors to access their primary disk units on a boot.
21	Removes force on primary disk unit select.
22	Same as 20, except forces the processors to access their secondary disks.
23	Removes force on secondary unit select.
24	Inhibits the sanity timer from expiring and initiating automatic recovery action.
25	Removes the sanity timer inhibit.
26	Releases any trapped failure Processor Recovery Messages (PRM) and causes the next failure PRM to be displayed in reverse video and to remain displayed until released.
27	Releases any trapped failure PRMs and allows further PRMs to be displayed.
30 ^a	Forces the processor to initialize from the backup root file system.
31	Allows the processor to initialize from the primary root file system.
32	Forces the processor to initialize only the <i>UNIX</i> RTR (Real-Time Reliable) operating system. The application software is not initialized.
33	Allows the processor to initialize both the <i>UNIX</i> RTR operating system and the application software.
34	Inhibits hardware checks from initiating automatic recovery action.
35	Allows the hardware checks to initiate automatic recovery action.
36	Inhibits software checks from initiating automatic recovery action.
37	Allows software checks to initiate automatic recovery action.
38	Inhibits error interrupts.
39	Allows error interrupts.
42	Allows the setting of a parameter which is made available to application software.
43	Clears the application parameter.
50	Signals the application software to initialize.
51 ^b	Forces initialization of the <i>UNIX</i> RTR operating system (level 1 initialization).
52	Reloads the <i>UNIX</i> RTR operating system from disk (level 2 initialization).
53	Same as 52, plus reloads Equipment Configuration Data (level 3 initialization).
54	Same as 53, plus clears the memory (level 4 initialization).

See note(s) at end of table.

Table 2-10 — Emergency Action Interface (EAI) Maintenance Commands (Contd)

COMMAND	DESCRIPTION
55 ^c	Loads selected disk from tape unit 0.
57	Same as 54 plus reboots the 3B21 emulator.
58	Same as 57 plus reboots <i>Solaris</i> System V Release 4 OS
59	Stops the 3B21 emulator, thus stopping the AM.
Note(s): a. Commands 30 through 43 generate the next state of the maintenance teletypewriter (MTTY) peripheral control information which is sent to the processor the next time commands 50 through 55 are executed. b. Commands 51 through 55, in addition to the description given, cause the current next state information to be sent to the processor. c. Command 55 requires a disk unit to be selected (commands 20 or 22).	

2.9.5.3 MCC Page 111/112 - AM, AM Peripherals

The purpose of the 111/112 display page is to report the status of the AW (shown as AM on the screen) and its peripherals. The AW peripherals are the MHDs, MT, MTTY, ROP and the link to the switching module.

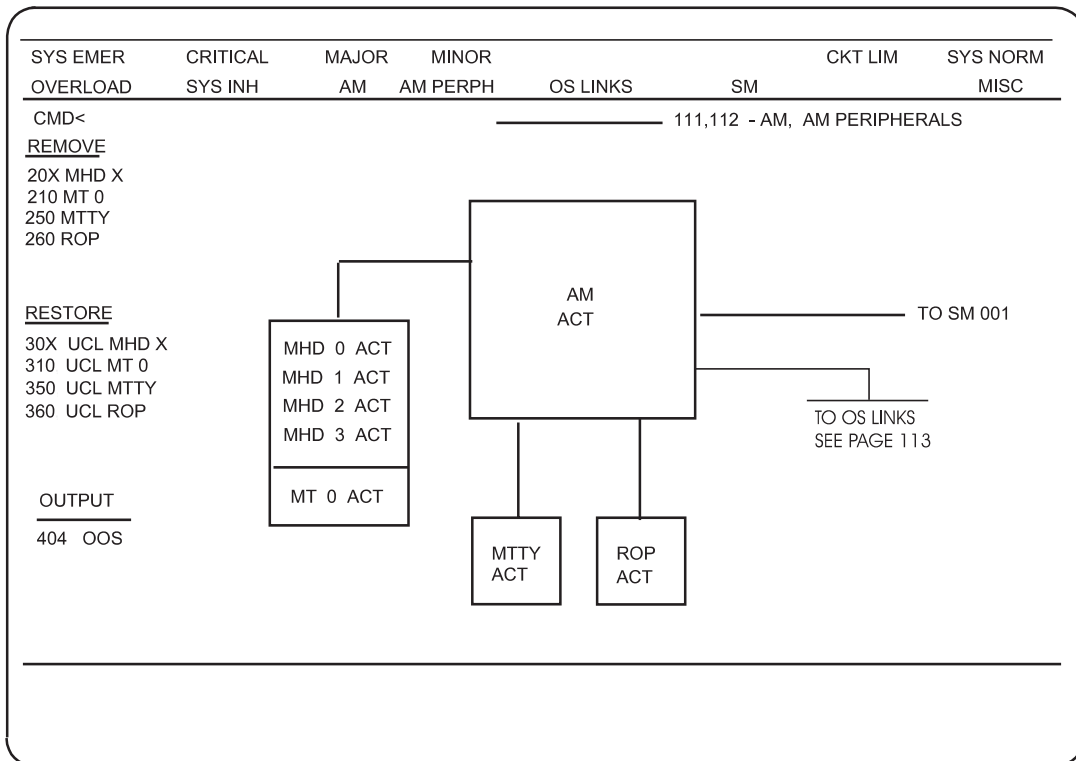

Figure 2-34 — MCC Display Page 111,112 AM, AM Peripherals

Figure 2-34 is an example of the DRM version of the 111/112 display page. Note that all restore pokes are executed with the unconditional (UCL) option.

An off-normal condition on this page will cause the AM or AM PERPH indicator at the top of the screen to backlight. In this case, the appropriate alarm level (CRITICAL, MAJOR, MINOR) will also backlight.

2.9.5.3.1 Abbreviations

OOS	Out Of Service
ACT	Active
MTTY	Maintenance Teletypewriter
ROP	Receive-Only Printer
UCL	Unconditional

2.9.5.3.2 Commands

The 111/112 page provides command to remove, restore, diagnose, and switch the various units. Also, output commands are available for out-of-service and diagnostic listings.

CMD	RESULT
20X	MHD X is removed (RMV: MHD=X)
210	MT 0 is removed (RMV:MT=0)
250	MTTY 0 is removed (RMV:MTTY=0)
260	ROP 0 is removed (RMV:ROP=0)
30X,UCL	MHD X is unconditionally restored (RST:MHD=X,UCL)
310,UCL	MT 0 is unconditionally restored (RST:MT=0,UCL)
350,UCL	MTTY 0 is unconditionally restored (RST:MTTY=0,UCL)
360,UCL	ROP 0 is unconditionally restored (RST:ROP=0,UCL)
404	OOS units are listed at ROP (OP:CFGSTAT, OOS)

2.9.5.4 MCC Page 113 - Operations Systems Links

The 113 display page provides a listing of Operations Systems links and their status.

SYS EMER OVERLOAD	CRITICAL SYS INH	MAJOR AM	MINOR AM PERPH	OS LINKS	SM	CKT LIM	SYS NORM MISC
CMD: _____ 113 - OPERATIONS SYSTEMS LINKS							
OS	LINK	TYPE	DEVICE			TIME BUFF	DATA BUFF
SCANS	PRIMARY	DIAL-UP	SDL 0 ACT	_____	_____	N/A	N/A
AMADL1	PRIMARY	DIAL-UP	SDL13 ACT	_____	_____	N/A	N/A
SCC	PRIMARY	DEDICATED	SDL 1 ACT	_____	_____	N/A	N/A
_____	PRIMARY	DEDICATED	SDL ACT	_____	_____	N/A	N/A

Figure 2-35 — MCC Display Page 113

Figure 2-35 shows an example of display page 113 for the DRM.

The Software Change Administration and Notifications System 2 (SCANS2) is used to transmit Software Updates (SUs) to both the office and the Switching Control Center (SCC) in previous 5ESS releases where Lucent Electronic Delivery (LED) is not available.

The Automatic Message Accounting Data Link (AMADL) connects the Automatic Message Accounting Teleprocessing System (AMATPS) with a Revenue Accounting Office (RAO) to assemble billing data locally at the DRM in older 5ESS releases where AMADNS is not available.

The SCC connects the office to the SCC System (SCCS) which monitors and administers the office.

The EADAS connects the office to the EADAS system which collects engineering and administrative data previous 5ESS releases.

2.9.5.5 MCC Page 116 - Miscellaneous Status

The 116 display page provides a status display for various units/activities which do not fall under any other grouping. For DRM configurations, miscellaneous alarms are shown on display page 1400. Figure 2-36 shows the 116 display.

SYS EMER OVERLOAD	CRITICAL SYS INH	MAJOR AM	MINOR AM PERPH	OS LINKS	SM	CKT LIM	SYS NORM MISC
CMD<						116 - MISCELLANEOUS	
<u>INHIBIT</u>							
601 CALL MONITOR			CALL MONITOR		SM FILE	NORMAL	
			INHIBIT	ALARM	MTIB	SEE PAGE 127	
<u>ALLOW</u>						CUTOVER SEE PAGE 197	
701 CALL MONITOR			GENERIC RETROFIT		BWM AUTOMATION SEE PAGE 1941		
<u>RETIRE</u>							
801 CALL MONITOR ALM			ODD EVOLUTION				
<u>OUTPUT</u>							
901 CALL MONITOR			ODD WARNING	RCLOG WARNING			
902 ODD WARNING			RC BACKUP NORMAL				
903 RCLOG WARNING							

Figure 2-36 — Miscellaneous Status Summary - MCC Display Page 116

The CALL MONITOR indicator shows whether the Call Monitor is inhibited or allowed. Entering the command 601 generates the message **INH:CALLMON** which will inhibit the monitor from making test calls and performing call completion analysis. This also clears the monitor's history data. The command **701** generates the message **ALW:CALLMON** which allows the monitor to start the cycle of making test calls and performing call completion analysis. Command **801** generates the message **RTR:CALLMON,ALARM** which retires the alarm indicator in the Call Monitor box. Command **901** generates the message **OP:CALLMON** which generates the OP CALLMON PAST 15 MINUTE REPORT on the ROP.

The indicator GENERIC RETROFIT will backlight and change to GENERIC RETROFIT ACTIVE when software release (generic) retrofit is in progress.

The indicator ODD EVOLUTION will backlight and change to ODD EVOL ACT when ODD Evolution is in progress. ODD Evolution is initiated by the command **BKUP:ODD,ODDEVOL** and stays in effect until the actual software release cut-over takes place.

The indicator ODD WARNING will backlight when either the amount of ODD space being used has exceeded the engineering recommendations for the AM or the automatic relation engineering reorganization process has failed on one or more relations in the AM. Entering the command **902** generates the input message **OP:ODDWARN,AM** which will generate the OP ODDWARN output message on the ROP.

The RCLOG WARNING indicator will backlight when the recent change log reaches 80 percent full. Enter poke 903 to output the recent change log status. To clear a RCLOG WARNING, perform Backup ODD.

The RCLOG WARNING indicator is provided on the 116 page. A major alarm occurs and this indicator is backlighted when the RC log files approach full capacity. The 903 poke provides additional information.

The RC BACKUP indicator normally shows NORMAL on the right part of the indicator. If RC Backup fails in the AM, the text NORMAL changes to FAILURE and the entire indicator backlights.

The next indicator, MTIB, will backlight if an off-normal condition exists on the MTIB display. Enter command **127** for further details.

In the CUTOVER indicator, the word ACTIVE will backlight if an off-normal condition exists on the CUTOVER display (cut-over enabled, for example). Further information can be found on display 197 - CUTOVER.

The indicator BWM AUTOMATION will backlight when the BWM automation process is halted for any reason.

The indicator SM FILE shows NORMAL (in the right portion of the indicator) while the system is operating normally. If the UPD:HSCHK audit finds hashsum errors on any of the SM/SM peripheral, the indicator will backlight and NORMAL changes to HASHERR. For more information, analyze the last output message from the UPD:HSCHK command (on the ROP) or request a summary report of the errors via the UPD:HSCHK,REPT option of the command. The indicator is cleared when the cause if the disk hashsum error has been corrected and the UPD:HSCHK audit is re-run.

2.9.5.5.1 Abbreviations

HASHERR Hashsum Error

MTIB Metallic Test Interface Bus

2.9.5.5.2 Commands

Commands are provided to inhibit and allow the call monitor, output the past 15-minute interval history for the call monitor, retire a call monitor alarm or output ODD WARNING information.

Also, all available displays can be accessed from the 116 display page.

CMD	RESULT
601	Call Monitor is inhibited (INH:CALLMON)
701	Call Monitor is allowed (ALW:CALLMON)
801	Call Monitor alarm is retired (RTR:CALLMON,ALARM)
901	Call Monitor history is output (OP:CALLMON)
902	ODD WARNING information is output (OP:ODDWARN,AM)
903	RCLOG WARNING information is output (OP:RCSTAT,AM)

2.9.5.6 MCC Page 124 - DCI/ASM Status

The purpose of the 124 page on the DRM is to provide information about the ASM and the DCI link. The DCI link for a DRM is a Virtual DCI (VDCI) link over the network connection to the ASM. The DRM 124 page contains the same information as that on a 3B21 with one exception, only a 3B21 can have a connection to the ASM console port. Therefore, the bottom box on the 124 page (ASMLNK) which displays the status of the console port will not display on the 124 page on a DRM. Figure 2-37 shows the 124 page.

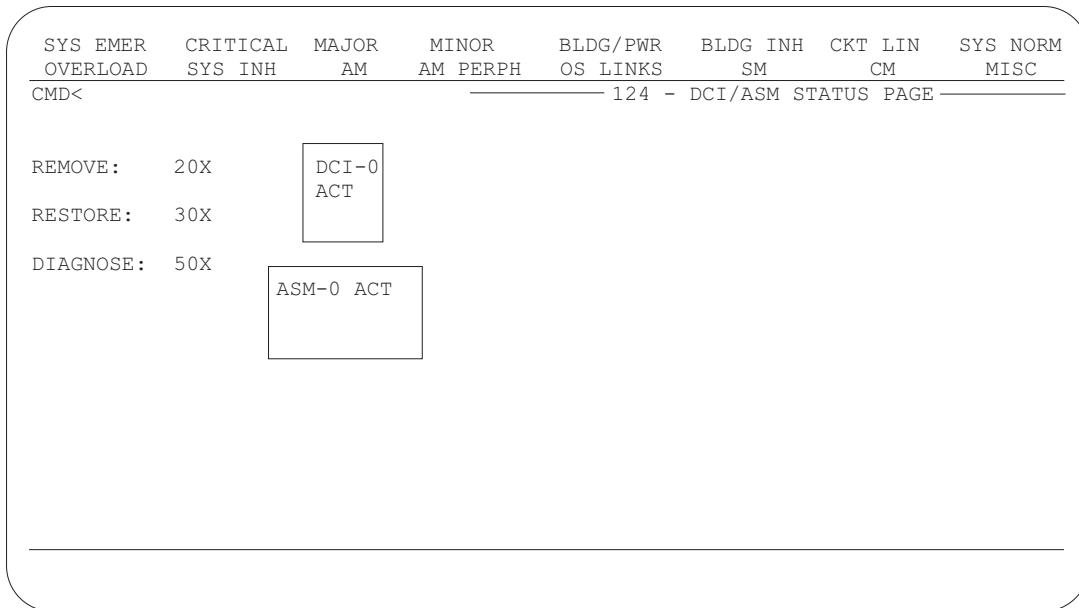

Figure 2-37 — MCC Display Page 124

2.9.5.7 MCC Page 1190 - MCTSI Status

The purpose of the 1190 page display is to show status and provide maintenance commands for the Module Controller/Time Slot Interchanger (MCTSI) and the external timing references. Figure 2-38 shows the 1190 page.

When an off-normal condition occurs, the indicator for the condition backlights. On Page 1010,X, the MCTSI indicator backlights. On Page 114, the indicator for the switching module backlights; and on the appropriate 141, 142, 143, or 144 page, the indicator for the switching module backlights, and a phrase describing the problem is written, unless a more critical condition exists. In the SUMMARY STATUS AREA, the switching module critical indicator and the alarm level (CRITICAL, MAJOR, or MINOR), if applicable, are backlighted.

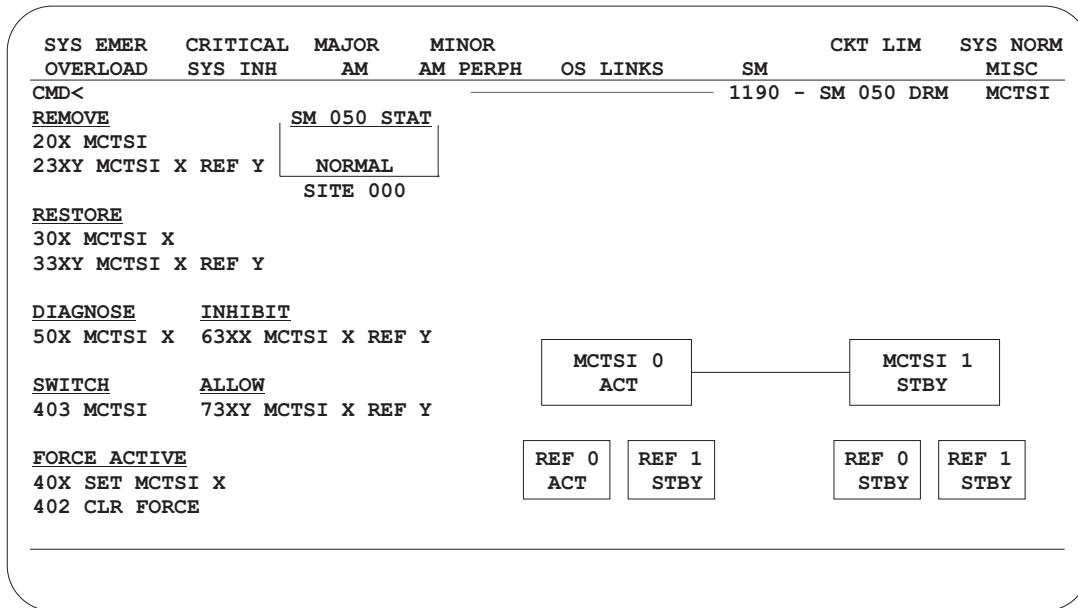

Figure 2-38 — MCC Display Page 1190

The MCTSI status data is stored in the switching module.

2.9.5.7.1 Commands

Commands are given to remove, restore, and diagnose the MCTSI or external timing references and to switch the MCTSI or to force active the MCTSI. Any available paging commands can be entered from the 1190 page.

CMD	RESULT	
20X	MCTSI X is removed.	(RMV:MCTSI=SM#-X) [,UCL]
23XY	MCTSI X REF Y is removed	(RMV:SMREF=SM#-X-Y)
30X	MCTSI X is restored.	(RST:MCTSI=SM#-X) [,UCL] [,STBY]
33XY	MCTSI X REF Y is restored.	(RST:SMREF=SM#-X-Y)
50X	MCTSI X is diagnosed.	(DGN:MCTSI=SM#-X,RAW,TLP) [,UCL] [,GROW] [,RPT] Test is repeated 32,767 times. [,RPT=a] The "a" is the number of times the test is to be repeated (1-32,767). [,PH=b b&&c] The "b" is the diagnostic phase or "b&&c" is the range of phases to be performed.
63XY	MCTSI X REF Y is inhibited.	INH:HDWCHK,SMREF=SM#-X-Y
73XY	MCTSI X REF Y is allowed.	ALW:HDWCHK,SMREF=SM#-X-Y
40x	MCTSI X is forced active.	

CMD	RESULT	
402	MCTSI forces cleared.	
403	MCTSI is switched.	(SW:MCTSI=SM#)

2.9.5.8 MCC Page 1400 - Switching Module BLDG/PWR Alarm Status

The purpose of the 1400,X page is to display all building/power alarm status and assignment and the alarm retire mode. It also provides inhibit/allow controls for building alarms.

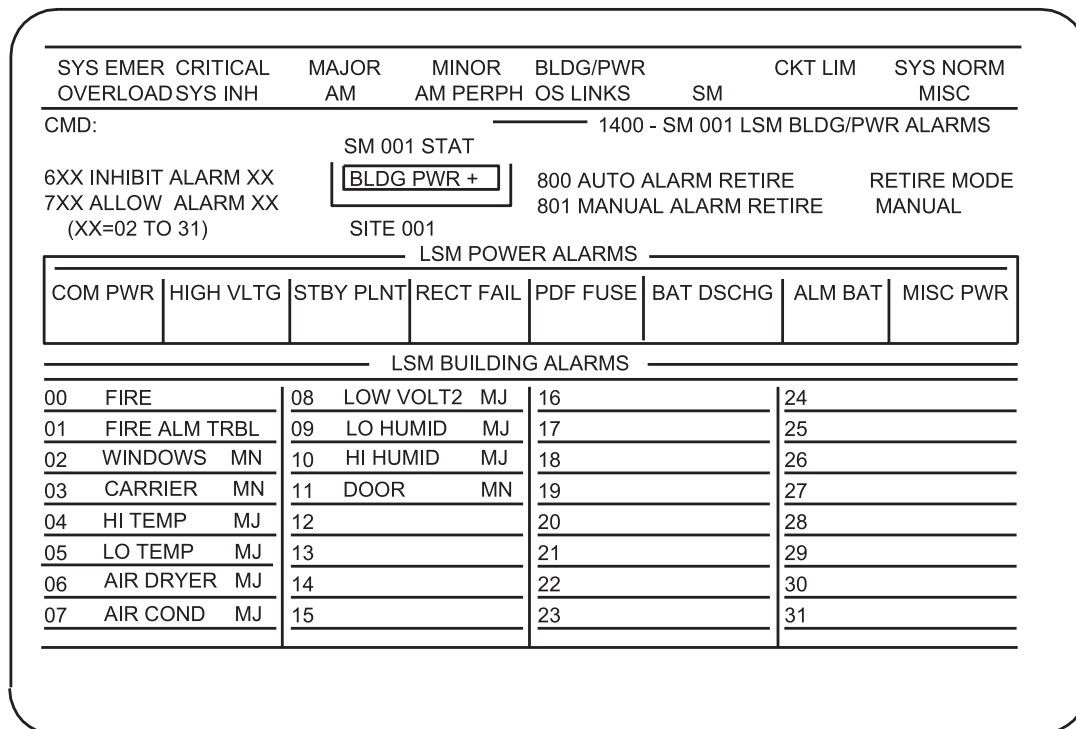

Figure 2-39 — MCC Display Page 1400

The Alarm Status Unit (ASU) provides audible and visual indication of the office alarms with LEDs for the alarm levels (critical, major, minor). There is an Alarm Retire key at the ASU which retires the audible alarms and clears the alarm level LEDs at the ASU with no effect on the SSA of the terminal.

A normal alarm indicator is displayed in normal video (white on black). Figure 2-39 provides a view of the 1400 page.

Building alarms 02-31 and their alarm levels are office assignable. Doors, windows, humidity, etc. are types of applications. The alarm level and text in these indicators are initially filled in using RC/V. Once these indicators are filled in, they are protected from loss if the system is booted.

2.9.5.8.1 Commands

The following commands are available to inhibit, allow, or retire alarms.

CMD	RESULT
6XX	Inhibit Alarm XX
7XX	Allow Alarm XX
800	Auto Alarm Retire
801	Manual Alarm Retire

2.9.5.9 MCC Keyboard

The local DRM MCC keyboard keys are used in a normal fashion to enter numeric codes, input messages, and alphanumeric responses to the system. Certain keys are used for administration as explained in the remainder of this section.

The MCC uses five function keys. When one of these keys (see Figure 2-40) is depressed, the system performs the corresponding function. The keys are as follows:

- ALM RLS: alarm release
- CMD/MSG: input command or input message
- NORM DISP: normal display
- EMER DISP: emergency action display
- Control + ENTER (*not the return key*): UNIX mode key (switches between DRM mode and UNIX mode on the MCC).

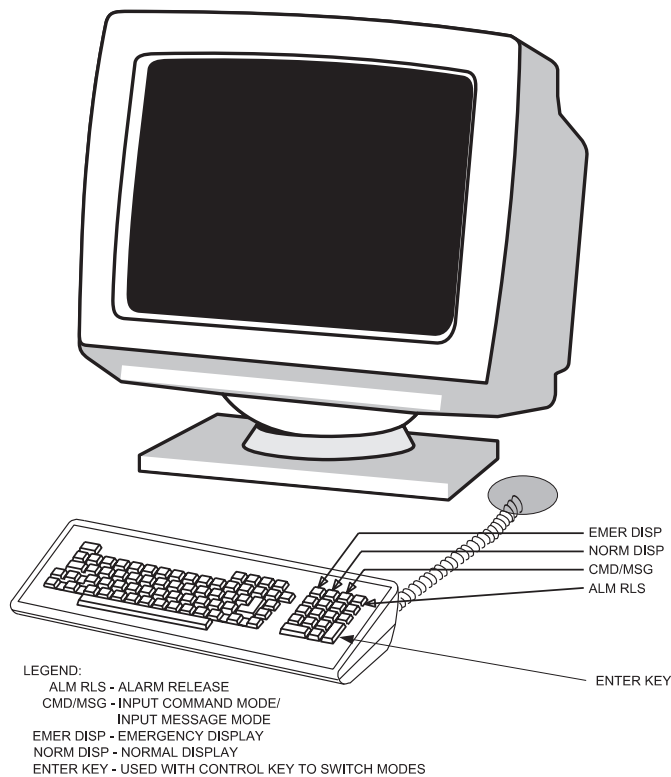

Figure 2-40 — MCC Video Terminal With Function Keys

2.9.5.9.1 Alarm Release Function Key

There are two system alarm release modes: automatic alarm release and manual alarm release. If the system is in the automatic alarm release mode, the audible alarm and the flashing alarm conditions are released 8 seconds after initialization. If the system is in the manual alarm release mode, the audible alarm and flashing alarm conditions are released by depressing the ALM RLS function key on the video terminal keyboard. Minor audible alarms are retired after 8 seconds in either mode. Released alarms and controls in effect remain in the alarm condition until the system has been restored to normal operating condition. The alarm release mode is changed via a maintenance command available on MCC display page 1400, or an input message. Refer to 235-105-110, *5ESS Switch System Maintenance Requirements and Tools*, for a complete listing of MCC status indicators and their meanings.

2.9.5.9.2 Input Command Or Message Function Key

The command/message (CMD/MSG) function key configures the MCC to accept either input CMDs or input MSGs. The key acts as a toggle and allows input in one mode or the other. Personnel may switch between either mode after acknowledgment of the previously entered message. Any unexecuted data in either area is lost if a switch is made before an acknowledgment is received. The position of the cursor on the video display indicates which input mode the MCC is in. The cursor resides in the input message line area while in the MSG mode. If the MCC is in the CMD mode, the cursor resides at the CMD entry area (at the top left of the control and display area). Whenever the display is brought on line or a new page is selected, the input mode will remain unchanged.

2.9.5.9.3 Normal Display Function Key

The NORM DISP function key places a page controlled from the emulated AM on the display screen. The page displayed will be the previously displayed page. Depressing the NORM DISP function key again will redraw a clean display without aborting any processes in progress.

2.9.5.9.4 Emergency Action Display Function Key

The EMER DISP function key enables the emergency action mode and displays the EAI page on the screen. See “Emergency Action Interface (EAI),” Section 2.9.5.2. This page is used during a system emergency for system recovery functions. To exit the EAI page, press the NORM DISP key.

2.9.5.9.5 Control + Enter Key

Press the Control + Enter key to switch between the *UNIX* system mode and the DRM mode on the MCC display. The Enter key is located on the right side of the keyboard in the numeric keypad section. Do not confuse the Enter key with the Return key on the main keyboard.

2.9.5.9.6 Data Entry Functions

Most other keyboard keys are used in a normal fashion to enter numeric codes, input messages, and alphanumeric responses to the system.

2.9.6 Receive-Only Printer (ROP)

The ROP provides the local office personnel with a means for obtaining a hardcopy printout of system messages. This printout provides a permanent copy of messages for future reference. Since the message may not always be displayed on the MCC video display, the printout may be the only copy of the message available to the maintenance personnel.

Every message the system generates is not necessarily printed at the ROP. Some messages are logged, while some are only printed at the originating terminal in response to an input message. Because of the large number of output messages that may be generated by the system, controls are available to the maintenance personnel to limit the volume of messages printed. For further information on 5ESS switch output messages, see 235-600-750, *Output Messages Manual*.

The ROP is connected to the following AW ports:

- Parallel port on the rear of a *Netra* 1120 and *Netra* 20
- SAI-1 serial port 7 on a *Netra* 240

Figures 2-41, 2-42 and 2-43 illustrate the optional interface connection between the ROP and the AW.

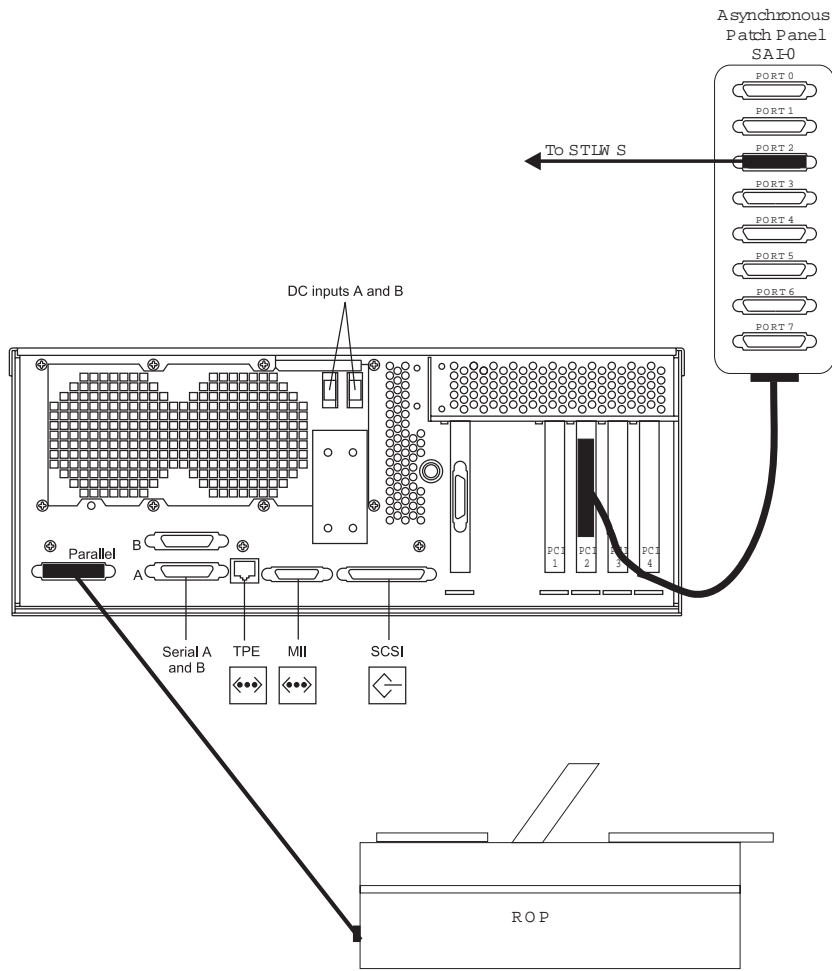

Figure 2-41 — STLWS and ROP Interface - Netra t 1120

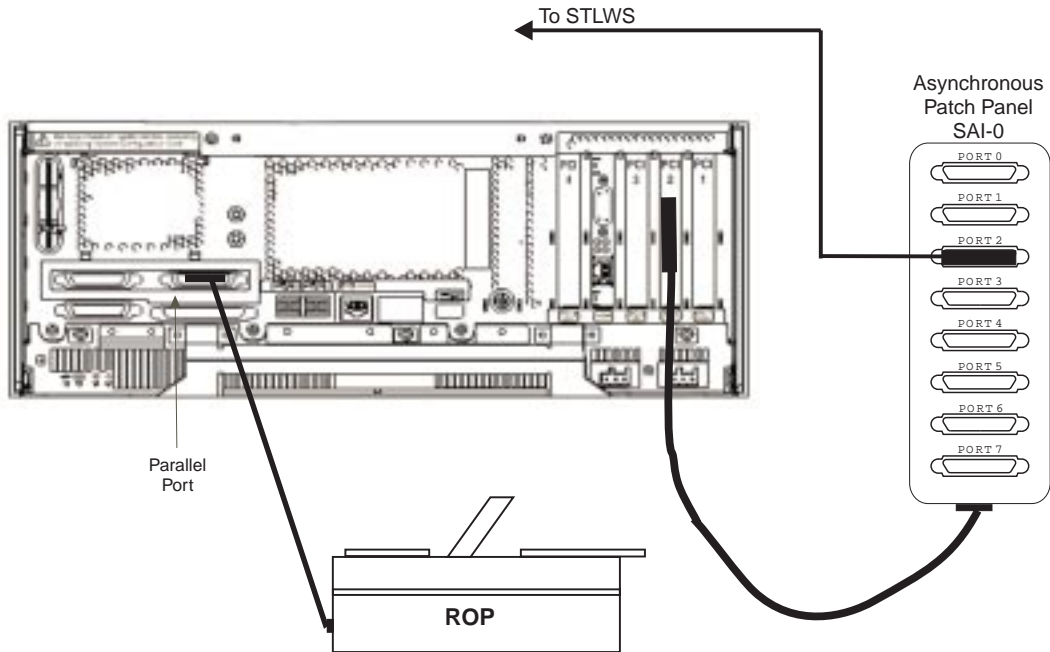

Figure 2-42 — STLWS and ROP Interface - Netra 20

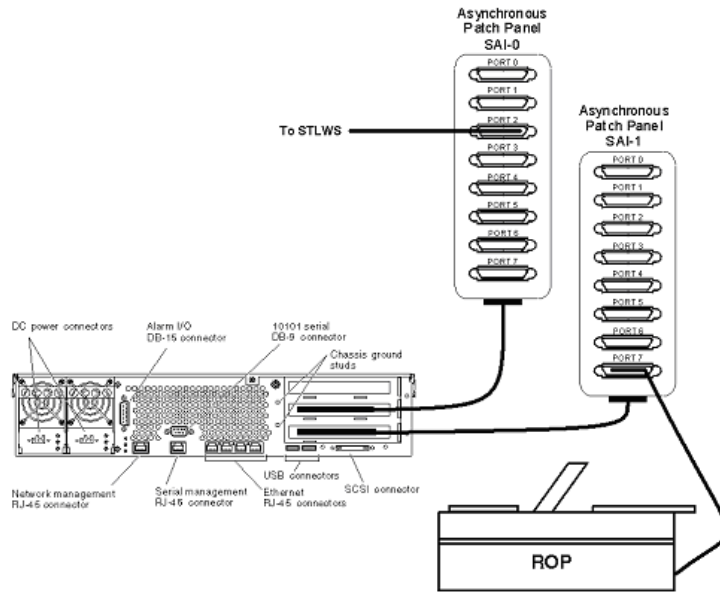

Figure 2-43 — STLWS and ROP Interface - Netra 240

Note: To modify ROP settings, refer to the Receive-Only Printer (ROP) Settings Procedure in Section 11 of the 235-105-210, *Routine Operations and Maintenance Procedures* manual.

2.9.7 Supplemental Trunk and Line Work Station (STLWS)

The Supplementary Trunk and Line Work Station (STLWS) is an optional local interactive menu interface used to test, monitor, or measure trunks and lines. The STLWS terminal is a Display Administration Process (DAP) type terminal. This means the office personnel can perform the same functions or commands from the STLWS that can be performed from the MCC, with the exception of being able to access the EAI page display.

Some of the operations that may be performed using the STLWS are as follows:

- Controlling lines and trunks being tested
- Monitoring a short circuit
- Measuring/sending frequencies
- Making continuous metallic measurements
- Providing remove or restore commands used for testing.

2.9.8 Recent Change (RC/V)

The RC/V system is a function that allows maintenance personnel access to a DRM's database. A DRM's database is a stand-alone ODD that is separate from the database at the Host. The RC/V system is used to add to, delete from, update, or verify a DRM's database. A stand-alone RC/V subsystem is provided at the DRM. Therefore, Operational Support System (OSS) interfaces are not required to use RC/V capabilities. The stand-alone RC/V enables office and/or maintenance personnel to change or verify the DRM's database using video displays and menu selection via a cut-through to the DRM through the ASM as explained in the 235-200-145, **5ESS Switch OneLink Manager Administrative Services Module (ASM) User's Guide**. For detailed information applicable to RC/V procedures, see 235-118-XXX (where XXX = the document number associated to the applicable software release), **5ESS Switch Recent Change Manual**, 235-000-000, **5ESS Switch Division 235 Numerical Index**, and associated documents.

Recent Change and Verify (RC/V) is a process used to modify each DRM's Office Dependent Data (ODD). RC/V:

- isolates the administrative process from the actual modification-of-the-data-base process
- provides a user-friendly view of the database.

The RC/V system is composed of many user interfaces which allow personnel to modify or verify the contents of the ODD. The RC/V facility currently provides the following interfaces:

- RC/V Menu Interface - immediate and batch release
- RC/V Text Interface - immediate and batch release
- Office Records (OFR)
- Recent Change Operations Systems (RCOS) Interface
- Facility Management (FM).

2.9.9 SCANS Data Link

Although all software updates are distributed from the ASM via the **Feature Deployment on ASM** feature, the DRM can support a local SCANS data link. See 235-200-145, **5ESS Switch OneLink Manager™ Administrative Services (ASM) User's Guide** for more information.

The Software Change Administration and Notification System (SCANS) is a software support package provided by Lucent technologies. SCANS provides the following services:

- Distributing emergency software fixes
- Distributing bulletins, or information about generic software fixes
- Distributing Software Updates (SUs)
- Introducing new software features.

Figures 2-44, 2-45 and 2-46 show the interface connection of the SCANS terminal to the AW.

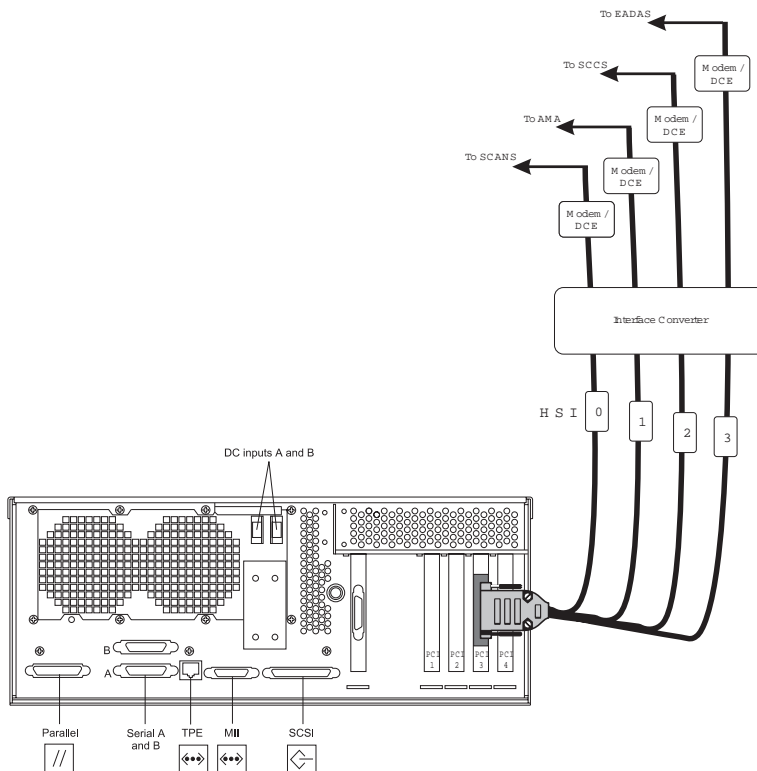

Figure 2-44 — SCANS/AMA/SCCS/Optional OSS Interface - Netra t 1120

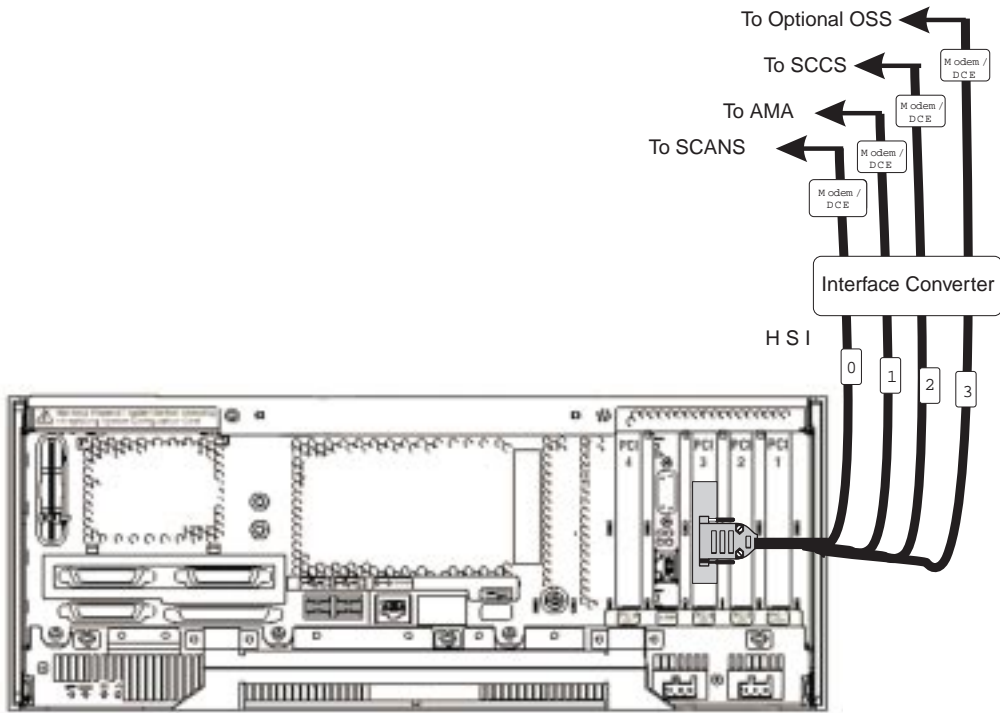

Figure 2-45 — SCANS/AMA/SCCS/Optional OSS Interface -Netra 20

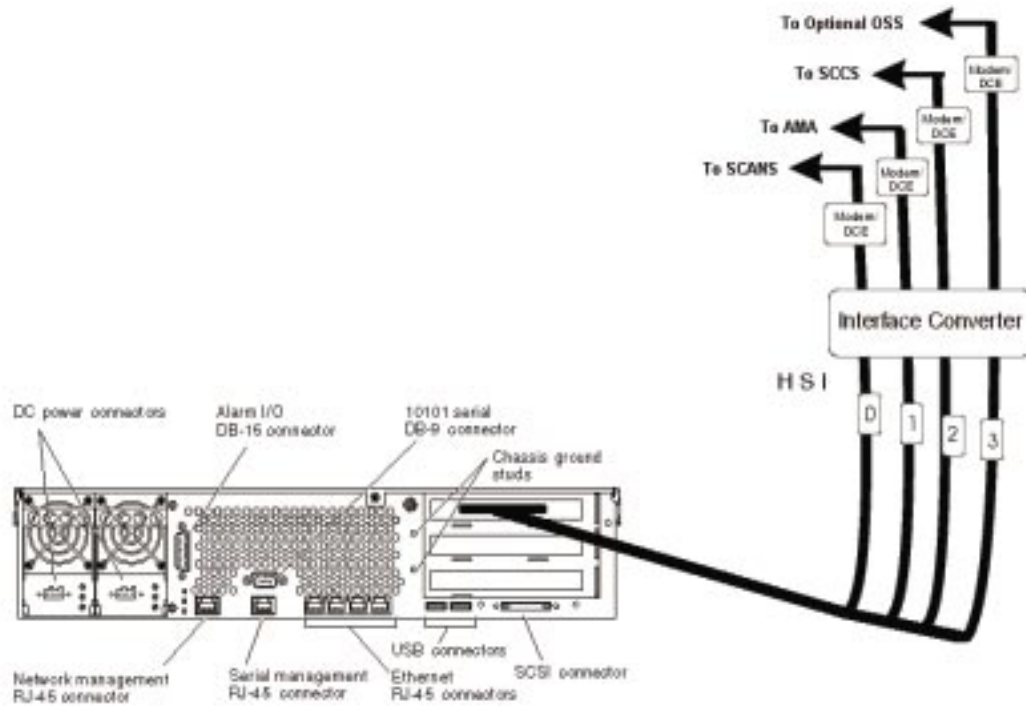

Figure 2-46 — SCANS/AMA/SCCS/Optional OSS Interface -Netra 240

2.9.10 Automatic Message Accounting (AMA) Data Link

Billing activities are performed at the ASM via tapes, a datalink, or the AMADNS application (if purchased). For the AMADNS application, a local AMA data link, AMATPS, can be connected at the DRM. The Billing and Data Systems (*BILLDATS*¹¹) is a software system whereby a host collector receives billing data from the DRM. Figures 2-44, 2-45 and 2-46 show the AMA data link which provides the hardware interface requirements for the *BILLDATS* system. For more information about the AMA data link, see 235-070-100, *5ESS Switch Administration and Engineering*

11. Registered trademark of AT&T Corp.

Guidelines and 235-190-300, *5ESS Switch Billing Features and Specifications*. (See 235-200-145, *5ESS Switch OneLink Manager Administrative Services Module (ASM) User's Guide*, for more information on AMADNS.)

2.9.11 Switching Control Center System (SCCS) Data Link

The SCCS is an optional remote office control system. It allows centralized control of many offices in remote locations. The SCCS provides service providers with capabilities nearly identical with those described for the MCC in “Master Control Center (MCC)”, Section 2.9.5.

These capabilities include; removing and restoring hardware units, performing recent changes, applying SUs, and commanding an initialization. Figures 2-44, 2-45 and 2-46 illustrate the SCCS connections to the AW.

2.9.12 EADAS

The Engineering and Administrative Data Acquisition System (EADAS) connects the office to an EADAS system which collects engineering and administrative data. Figures 2-44, 2-45 and 2-46 illustrate the EADAS connections to the AW.

2.10 Terminal Security

Certain commands in the DRM can be password protected to restrict access to authorized personnel. Refer to 235-700-200, *UNIX RTR Operating System Reference Manual*. Also, any terminal except the MCC channel can be modified to require a login by making the necessary Equipment Configuration Data (ECD) changes. Access to RC/V can be limited by using the **SET:RCAC** message. Refer to 235-118-XXX (where XXX = the document number associated to the applicable software release) , *5ESS Switch Recent Change Reference Manual*.

2.11 DRM Software

The DRM software is composed of the AW software and the switching module software.

2.11.1 Administrative Workstation (AW) Software

The architecture of the AW software appears in Figure 2-47.

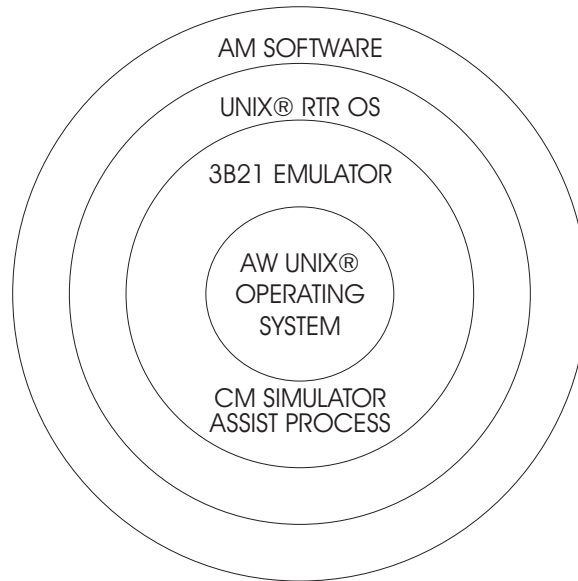

Figure 2-47 — AW Software Architecture

The AW provides the same functions provided by the AM. These are those functions that are best performed out of the call processing environment:

- Administrative
- Maintenance.

In addition, the AW provides the CM2 function of passing messages from the AM to the switching module.

The AW contains special software which allows the functionality of the AM and CM2 to be economically provided for the single-switching-module DRM. At the center of the software is the AW's *UNIX* Operating System (see Figure 2-47).

Running on the next layer is the AM 3B21 emulator, assist processes, and the CM2 simulator. This layer of software is essentially mimicking, or emulating, the actions of the AM's 3B21D computer. The 3B21D computer is a highly reliable — fault tolerant computer capable of providing administrative and maintenance functions for up to 192 switching modules. This level of sophisticated hardware is not necessary for the single-switching-module DRM. Thus the hardware has been replaced by a software program which emulates its actions. The CM2 simulator simulates the actions of the CM2 in passing messages from the AM software to the switching module. Again, in the single-switching-module DRM, the CM2 is not necessary. Its primary role was to perform switching between switching modules, and in the case of the DRM, there is only one switching module.

Running on the next layer is the *UNIX* Real Time Reliable (RTR) Operating System. This operating system normally runs on the 3B21D computer and provides the functions needed for the AM software to run on the 3B21D.

Running on the outer layer is the AM software. This is the same feature-rich software which runs on the 5ESS switch and CDX switch AM.

2.11.2 Switching Module Software

The switching module software provides all call processing and the necessary control software to allow the switching module to communicate and pass data to and from the AW.

2.12 Features

The DRM supports most of the features (for example, ISDN, Centrex) of the 5ESS switch.

2.12.1 Signaling System 7 (SS7)

Signaling is provided by the Packet Switching Unit (PSU). For detailed information on SS7, see 235-200-1165 *5ESS Switch Signaling Gateway Common Channel Signaling Document*.

2.12.2 Session Initiation Protocol (SIP)

Session Initiation Protocol (SIP) - also supported on the PSU, for details see 235-200-1185 *5ESS Switch Session Initiation Protocol - OAM Manual*

2.12.3 Automatic Message Accounting (AMA)

The AMA feature is a billing feature that provides control, collection, and recording of AMA data.

In case of an AW outage, the switching module is capable of storing 72 hours of Automatic Message Accounting (AMA) data before requiring download to the AW for storage on the hard disk.

A switching module circular AMA data buffer protects AMA data by ensuring that certain pointers in the AMA storage area are not updated until the AMA data can be retrieved once the AW is restored.

For more information on AMA, see 235-190-300, *5ESS Switch Billing Features and Specifications*.

2.12.4 AMADNS

Automatic Message Accounting Data Network Service (AMADNS) for DRM can be either sender or receiver initiated.

For more information on AMADNS, see the following documents:

- 235-100-125, *5ESS Switch System Description*
- 235-190-300, *5ESS Switch Billing Features and Specifications*
- 235-118-25X, *5ESS Switch Recent Change Reference Guide*
- 235-040-100, *5ESS Switch OA&M Planning Guide*
- 235-600-700, *5ESS Switch Input Messages Manual*
- 235-600-750, *5ESS Switch Output Messages Manual*
- 190-136-166, *Billdata Data Server 5ESS Switch AMADNS Phase 1 Operations Guide*

2.12.5 Software Release Retrofit

A software release retrofit is performed to transition from one software release to another. To perform a retrofit, see 235-106-10X (where X = the document number associated to the applicable software release), *5ESS Switch Software Release Retrofit*

Procedures. The appendices in this IP relating to retrofit are high level outlines and are intended only as a supplement to the retrofit manual.

2.12.6 Software Release Update

A software release update is performed to transition from one software release text load to another. To perform a software release update, see 235-106-20X (where X = the document number associated to the applicable software release), **5ESS Switch Software Release Update Procedures.**

2.12.7 Software Update

2.12.7.1 Software Update Download

Software Updates (SUs) on the ASM can automatically be sent to the Host and the DRMs in the Switching Complex using the tool *dsdownload*. Separate directories are provided for the Host and each DRM's SUs. These directories are */app/su/download/3B* and */app/su/download/VCDX*. SUs are sent to the Host Administrative Module (AM) over the DCI link, and to the DRMs via the Switching Complex data and transmission network. On the Host AM and DRMs, the SUs are placed in */etc/bwm*.

Note: To download TMP or Unofficial Craft SUs, (refer to procedure - *Handling 5ESS TMP and Unofficial CRAFT SUs* in the ASM User's Guide.)

After an SU has been successfully sent to the Host and all DRMs in the Switching Complex, it is deleted from the ASM disk.

Note: SFID 320, "Feature Deployment on ASM," must be active on the Host and each DRM for the files to be automatically sent.

2.12.7.2 Software Update Automation

Once an SU has been sent to the */etc/bwm* directories, the SU can be applied by either using a cut-through to each Host/DRM and manually applying the SU or using SU Automation to automatically apply the SU to the Host and all DRMs in the Switching Complex.

This feature can only be used for SU installation on the Host and all the DRMs in the complex together. If SU installation on only the Host or a subset of DRMs is desired, then it must be done via a cut-through to each Host/DRM's MCC.

An SU can be scheduled for automatic installation across the Switching Complex **only if the Host and all DRMs are on the same release and SU level**. If not, attempts to schedule an SU for automatic installation will be rejected.

SU automation commands are sent to the Switching Complex by writing them to a file (referred to as an "automation command file" or "command file") and placing the file in the ASM directory */app/su/automation/autocmd/*. The command file will be automatically sent to the Host and all active DRMs. After the file has been sent, it is moved to the directory */app/su/automation/sent*.

Note: The user is responsible for verifying the form and syntax of SU Automation command files. If invalid SU Automation commands are included in a command file, they will simply not be processed and no error output will appear.

On the Host and each DRM, the commands in the file are executed as if they were inputs to the 1941 page on the MCC. The changes to the state of SU automation are recorded in a results file on the ASM. If any error conditions occur, such as a communications failure between the ASM and the Host or a DRM, it will also be

reported in the results file. The pathname of the results file is
/app/su/automation/autoslts.

The results file will subsequently be sent to a remote host using one of three file transfer mechanisms: FTP, RCP, or UUTO. The destination of the results file and the method used for file transfer are specified in a configuration file on the ASM.

2.12.7.3 Software Update Automation Commands

The complete set of SU Automation commands that can be included in a command file is as follows:

Command in autocmd file	Description
INHIBIT	Inhibit SU Automation (turn it off).
ALLOW	Allow SU Automation (turn it on).
QUERY_STATUS	Determine if SU Automation is ON/OFF.
QUERY_HEALTH	Run the SU Automation health check.
QUERY_SCHEDULE	Determine if an SU is scheduled for automatic installation through SU Automation.
SCHEDULE_SU	Schedule SU for automatic installation.
BWM98-0001 OFC 12011998 2200	An automatic SU install of BWM98-0001 to the official state should begin on 12/1/1998 at 10pm. Requires all four arguments.
UPDATE_HEALTH_CHECK	Update health check array (on/off).
XXXXXXXXXXXXXXXXXXXXX	where each X = Y N Y=on, N=off and the first X is health check 0 the second X is health check 1 and so on...
XXXXXXXXXXXXXXXXXXXXX	
UPDATE_OFFICE_PROFILE	Update the SU Automation office profile.
INSTATE <stage>	<stage> = VFY SOAK OFC
SOAKTM HHMM	HHMM = SU install soak time.
ALARMLVL <alvl>	<alvl> = MAJOR MINOR
CSCANS <cs>	<cs> = Y N
WARNTM HHMM	HHMM = Warning time before SU Automation begins.
PROCINIT HH	HH = Last processor init time (health check).
CLRBWM <clr>	<clr> = Y N
SUNOFF <begin><end>	<begin> = HHMM SUNDAY off interval. <end> = HHMM SUNDAY off interval.
MONOFF <begin><end>	<begin> = HHMM MONDAY off interval. <end> = HHMM MONDAY off interval.
TUEOFF <begin><end>	<begin> = HHMM TUESDAY off interval. <end> = HHMM TUESDAY off interval.
WEDOFF <begin><end>	<begin> = HHMM WEDNESDAY off interval. <end> = HHMM WEDNESDAY off interval.
THUOFF <begin><end>	<begin> = HHMM THURSDAY off interval. <end> = HHMM THURSDAY off interval.
FRIOFF <begin><end>	<begin> = HHMM FRIDAY off interval. <end> = HHMM FRIDAY off interval.
SATOFF <begin><end>	<begin> = HHMM SATURDAY off interval. <end> = HHMM SATURDAY off interval.
END_ARG ^a	Indicates the end of the argument list for UPDATE_OFFICE_PROFILE.

See note(s) at end of table.

Note(s):

- a. When the UPDATE_OFFICE_PROFILE command is used to update the SU Automation office profile, the list of attributes to be updated must be terminated with the command END_ARG. The END_ARG command must be placed on a line by itself.

2.12.7.4 File Transfer Configuration File

This file contains the information necessary to transfer the automation results file from the ASM to a remote system. The pathname of this file is */app/su/automation/autoxfr.cfg*. There are four fields in the configuration file, which contain the following information:

- the file transfer method
- the remote system to which the file is to be sent
- the user on the remote system who will receive the file
- the destination pathname on the remote system.

Each field is on a separate line.

The user can create and modify the configuration file using a text editor such as *vi* or *emacs*. The fields need to appear in the file in the following order:

1. file transfer method
2. remote system
3. username on the remote system
4. remote pathname.

The format for these fields is described in the following sections.

2.12.7.4.1 File Transfer Method

This field consists of a single string indicating the file transfer method. The inputs ftp, rcp and uuto will select FTP, RCP, and UUTO respectively. The input for this field is case insensitive, so that FTP, ftp, or fTp all have the same meaning.

2.12.7.4.2 Remote System

If either FTP or RCP are chosen for the file transfer method, then the remote system must be specified by its full IP address. If UUTO is chosen, then the name of the remote host must be appear on the list of systems that are known to UUTO.

2.12.7.4.3 Username

This field consists of the login ID of the user on the remote system to whom the file will be sent.

2.12.7.4.4 Remote Pathname

This field gives the pathname of the destination file on the remote system. The conventions for specifying the remote pathname vary for the three file transfer methods:

- I. **FTP** - The remote pathname is optional. If it is omitted, the file will be copied to the user's home directory on the remote system and the remote file will have the same name as the local file. If it is included, the pathname can be either absolute or relative to the remote user's home directory. If the remote pathname

ends in a slash character, it will be interpreted as the name of a directory. In this case, the destination file will be placed in this directory and will have the same name as the local file. However, if the remote pathname is the pathname of a directory on the remote system and does not end in a slash, then FTP will attempt to overwrite the directory and file transfer will fail.

- II. **RCP** - As in the case of FTP, the remote pathname is optional, if it is omitted, the file will be copied to the user's home directory on the remote system and the remote file will have the same name as the local file. If the remote path is specified, it must be relative to the user's home directory on the remote system. If the remote pathname is the pathname of a directory, the file will be sent to that directory and will have the same name on the remote system that it has on the ASM.
- III. **UUTO** - The remote pathname is not specified for UUTO. If the file transfer mechanism is chosen to be UUTO, then this field is ignored.

2.12.7.4.5 Examples

The following configuration file will send the automation results file to user spacely on machine space with IP address space.sprockets.com:

```
ftp
space.sprockets.com
spacely
/home/spacely/rje/results.out
```

Alternatively, the IP address can be given explicitly (for example, 555.1.21.2.001). The path name of the destination on the machine space will be /home/spacely/rje/results.out.

This configuration file will send the results to the same destination as in the previous example using RCP instead of FTP:

```
rcp
space.sprockets.com
spacely
rje/results.out
```

Note that in this case the path name is specified relative to the remote user's home directory.

To send the results file to the same user using UUTO, the configuration file would look like:

```
uuto
space
spacely
```

The remote pathname does not apply to UUTO. The name of the remote system must be given as it appears on the list of systems known to UUTO.

2.12.7.5 File Transfer Methods

Before using any of the file transfer methods, certain files must be set up on the ASM or the remote Host. A brief description of these files is provided here. Further details can be found in the *Solaris* documentation.

2.12.7.5.1 FTP

FTP requires that a file with pathname */.netrc* exist on the ASM. This file must be readable only by the owner (root). The format of this file and the information it must contain are described in the *Solaris* documentation.

2.12.7.5.2 RCP

To use RCP, the user's *.rhosts* file on the remote system must include the user root on the ASM.

2.12.7.5.3 UUTO

UUTO setup involves the configuration of various files in the directory */etc/uucp*, as described in the *Solaris* documentation.

2.12.8 Features Not Supported in the DRM

Table 2-11 provides a list of features not supported in the DRM. For a complete list of 5ESS switch features, see 235-100-125, *5ESS Switch System Description*.

Table 2-11 — Features Not Supported in the DRM

FEATURE GROUP	NUMBER	NAME
ACD/MIS	99-5E-4086	ACD on DRM
ANS	99-5E-0835	Advanced Services Interface - Proxy (ASI-Proxy)
	99-5E-1501	Remote Access to ASI Proxy
CCIS	25-01-0500	Common Channel Interoffice Signaling (CCIS)
CNI	99-5E-0679	Support for CNI Features
	99-5E-0825	CCS7 ISDN User Part Enhancements
	99-5E-1101	CNI Data Structure Documentation/Modification of CNIDBOC
	99-5E-1136	Improvement - DLN30
	99-5E-1243	Improved DLN Overload Control Strategy
	99-5E-1282	Critical Node Restore Phase 2
DSN/AUTOVON	99-5E-0239	Polygrid Routing
Leased Network	99-5E-0480	Leased Network 100-Second Scan
	99-5E-0505	Leased Network 8-Hour Past MDR
	99-5E-0506	Leased Network MDR for Released Link Trunk
	99-5E-0557	Leased Network Action Point Routing & Billing
	99-5E-0558	Leased Network Action Point Screening
	99-5E-0560	ISDN Access to Leased Network Features
Network Management	99-5E-0685	Leased Network Service Selective Trunk Reservation (SSTR)
	99-5E-0777	NM Data Collection for 2000 Trunk Group
OSPS	99-5E-XXXX	All OSPS Features

Distinctive Remote Module (DRM)

	CONTENTS	PAGE
3. NETWORK PROCEDURES.		3 - 1
3.1 Local Log on to the Networking Router		3.1-1
3.2 Remote Log on to The Networking Router		3.2-1
3.3 Back Up the <i>DynaStar 500</i> (Base/Growth) Router Configuration File at the DRM Site		3.3-1
3.4 Back Up The <i>DynaStar 500</i> (Base/Growth) Router Configuration File at the Host Site		3.4-1
3.5 Restore the Configuration Settings for the <i>DynaStar 500</i> (Base/Growth) Router at the DRM Site		3.5-1
3.6 Restore the Configuration Settings for the <i>DynaStar 500</i> (Base/Growth) Router at the <i>5ESS</i> [®] Switch Host Site.		3.6-1
3.7 Configure the Router to Support Serial Asynchronous Interface (SAI) at the DRM Site		3.7-1
3.8 Set up the High Speed Interface to send NFM/SCC data to the <i>5ESS</i> [®] Switch Host Site		3.8-1
3.9 Set up the High Speed Interface to Send EADAS Data to the Host Site		3.9-1
3.10 Install the BRI to PRI to Back up the T1		3.10-1
3.11 DRM Network Element Software Download Procedure		3 . 1 1 - 1
3.12 Cajun Switch Software Version Procedure		3.12-1
3.13 DynaStar Router Software Version Procedure		3.13-1
3.14 Replace the Cajun P333T Ethernet Switch		3.14-1
3.15 Replace A <i>DynaStar 500</i> Host Router or Remote Router		3.15-1

LIST OF FIGURES

Figure 3.5-1 — Example of <i>Ethernet</i> Interface Parameters Screen With Field Values.	3.5-2
Figure 3.7-1 — PAD Port Configuration Menu with Sample Field Input	3.7-2
Figure 3.7-2 — The Async Services Menu with Sample Field Values	3.7-3

Figure 3.7-3 — Example X.3 Parameter Values Screen with Sample Field Values 3.7-5

Figure 3.7-4 — PAD Port Configuration for Remote RC/V with Sample Values 3.7-6

LIST OF TABLES

Table 3.11-1 — Host Router To DRM Mapping Table 3 . 1 1 - 2

Table 3.11-2 — IP Addresses and Software Versions Table. 3 . 1 1 - 3

Table 3.12-1 — Host Cajun IP Adresse and Software Version Table 3.12-2

Table 3.13-1 — DynaStar Router IP Addresses and Software Versions Table 3.13-2

Table 3.14-1 — VT100 Settings For Cajun Switch Replacement Procedure 3.14-2

Table 3.14-2 — RJ-45 Pin Assignment. 3.14-3

Table 3.14-3 — Verify Connectivity Between ASM and Host Router 3.14-6

Table 3.15-1 — VT100 Settings For DynaStar Router Replacement Procedure 3.15-2

Table 3.15-2 — RJ-69 Pin Assignment. 3.15-2

Table 3.15-3 — Compressed Configuration File Location For Host Router 3.15-3

Table 3.15-4 — Verify Connectivity Between ASM and Host Router 3.15-8

Table 3.15-5 — Verify Connectivity Between ASM and Remote Router 3.15-9

Table 3.15-6 — Verify Connectivity Between ASM and DRM 3.15-10

Table 3.15-7 — Verify Connectivity Between DRM and Remote Router 3.15-11

Table 3.15-8 — Verify Connectivity Between DRM and Host Router 3.15-12

LIST OF EXHIBITS

Exhibit 3.5-1 — IP Port Information Menu At DRM Site 3.5-3

Exhibit 3.6-1 — IP Port Information Menu At Host Site 3.6-3

3. NETWORK PROCEDURES

Network Procedures

The network components for the Lucent Technologies Network Component Solution (LNCS), as described in Section 2.7, consist of a smart *Ethernet*¹ switch at the host site, which is connected to routers at both the host site and each remote DRM site. The procedures that support the administration, maintenance, and provisioning of these components are included in this chapter.

Whenever any circuit card in any of the routers (host or remote) is faulty the recommended recovery procedure is to replace the entire unit. To shorten the recovery time, a backup copy of the unit's configuration file will be downloaded to the unit. This means that the configuration files must be stored on another device and backed up whenever there are any changes to the configuration.

For the remote networking router, the backup copy is stored at the DRM's AWS in `/dynastar/cnfgload.cmp`. A readable ASCII configuration file (filename=config) will also be backed up. It can be used for maintenance purposes.

For the host networking routers (host_a, host_b, and host_c), the backup copies are stored on the ASM in:

- `/varapp/dynastar/host_a/cnfgload.cmp` (host_a)
- `/varapp/dynastar/host_b/cnfgload.cmp` (host_b)
- `/varapp/dynastar/host_c/cnfgload.cmp` (host_c).

An ASCII configuration file (filename=config) will also be backed up. It can be used for maintenance purposes.

Procedures

The procedures necessary to support the administration, maintenance, and provisioning of the networking components include the following:

- Procedure 3.1 Local Log on to the Networking Router
- Procedure 3.2 Remote Log on to the Networking Router
- Procedure 3.3 Back Up the *DynaStar 500*² (Base/Growth) Router Configuration File at the DRM Site
- Procedure 3.4 Back Up the *DynaStar 500* (Base/Growth) Router Configuration File at the Host Site
- Procedure 3.5 Restore the Configuration Settings for the *DynaStar 500* (Base/Growth) Router at the DRM Site
- Procedure 3.6 Restore the Configuration Settings for the *DynaStar 500* (Base/Growth) Router at the Host Site
- Procedure 3.7 Configure the Router for Serial Asynchronous Interface (SAI) at the DRM Site
- Procedure 3.8 Set Up the High-Speed Interface for NFM/SCC Data to the Host Site

1. Registered trademark of Xerox Corporation.

2. Trademark of DYMEC, Inc.

- Procedure 3.9 Set Up the High-Speed Interface for EADAS Data to the Host Site
- Procedure 3.10 Install the BRI to PRI to Back up the T1
- Procedure 3.11 DRM Network Element Software Download Procedure
- Procedure 3.12 Cajun Switch Software Version Procedure
- Procedure 3.13 DynaStar Router Software Version Procedure
- Procedure 3.14 Replace the Cajun P333T Ethernet Switch
- Procedure 3.15 Replace A DynaStar 500 Host Router or Remote Router

3.1 Local Log on to the Networking Router

Purpose

Use this procedure to locally access the networking router.

When to Use

This procedure is performed prior to:

- configuring the router at the DRM site
- backing up the router configuration files
- restoring the router.

Before You Begin

A supervisor console (VT100 terminal or laptop) must be connected to the console (port 6 on the *DynaStar 500¹*) using the appropriate cables.

Required Tools

The following equipment is required to perform the procedure:

- PC with VT100 emulator software or a VT100 terminal is connected to port 6 of the networking router.

If the connection does not exist:

- At the back of the networking router, connect the cable with an RJ-69 interface to Port 6.
- At the back of the PC or VT100 terminal, connect the other end of the cable to the serial port.

Note: If a DB-9 cable is used, connect a DB-25 adapter to the DB-9 cable before connecting the cable to the back of the networking router.

- At the PC or VT100 terminal, verify that the communication parameters are set to 9600 bps and even parity (7 bits, even, 1 stop).
- A cable with an RJ-69 interface
- An RJ-69 to DB-25 connector
- A DB-9 to DB-25 connector (Customer provided)

Required Information

When the VT100 PC/terminal starts up, the *DynaStar 500* Supervisor page appears.

If the * prompt appears on the Supervisor Console, type and enter 9999 at the * prompt to display the DynaStar 500 Supervisor page.

PROCEDURE

1. At the *Enter Password:* prompt, type and enter `secret` (or the password set for your office).

Response: The Supervisor Console Types information appears.

1. Trademark of DYMEC, Inc.

Note: If a valid password is not entered within three attempts, the data call to the Supervisor is cleared and the X.28 PAD message CLR PAD is displayed. To be reconnected to the Supervisor, enter 9999 or power-cycle the Console.

2. Select the menu item "VT100 or ANSI compatible" by typing and entering 2 at the *Enter Console Type:* prompt.

Response:

The Main Menu page is displayed.

```
*** Main Menu ***

1 - Status          Board, addresses, statistics, enable/disable, error log
2 - Call control    Call set-up, disconnect, status
3 - Configuration   Dial directory, port, and application parameters
4 - System functions Date/time, applications, software load, restart
5 - Security        Passwords for Operator Access/TLL/IPX,IP Filter table
6 - Trace          SNA trace

Enter command number:
_____ [DRM50-MSS] _____
Terminate input with <RET> ESC to exit
```

Note: The Main Menu page is the reference point for all other forms that need to be completed.

3. **STOP. YOU HAVE COMPLETED THIS PROCEDURE.**

3.2 Remote Log on to The Networking Router

Purpose

Use this procedure to access the networking router from a remote location on the network.

When to Use

This procedure is performed prior to:

- configuring the router from the host site
- backing up the router configuration files from the host site
- restoring the DRM networking router from the host site.

Before You Begin

A supervisor console (VT100 terminal or laptop) must be connected to the network.

Required Tools

The following equipment is required to perform the procedure:

- PC with VT100 emulator software or a VT100 terminal is connected to the network.

Required Information

Before beginning this procedure, you must have the telnet address of the *DynaStar 500¹* router to be accessed. (This information should be stored in the office records.)

PROCEDURE

1. Enter telnet X

X = ip_address of the *DynaStar 500* to be accessed.

(For example, telnet 10.10.9.254)

Response: The services page appears:

```
1 CONSOLE 61b6
2 x25PDN DynaStar 633
3 x25PDN DynaStar 634
```

2. Enter 2 for the X25PDN choice.

Response: *

3. Enter 9999.

Response: Enter password:

4. Enter secret or the password set for your office.

Response: The Supervisory Console page is displayed:

```
Enter Console Type:
Supervisor Console Types
1-Myse 50 or TVI-910/920
2-VT100 or ANSI compatible
```

1. Trademark of DYMEC, Inc.

5. Enter 2 for the VT100 or ANSI compatible choice.

Response: The main menu is displayed:

```
*** Main Menu ***
1 - Status          Board, addresses, statistics, enable/disable, error log
2 - Call control    Call set-up, disconnect, status
3 - Configuration  Dial directory, port, and application parameters
4 - System functions Date/time, applications, software load, restart
5 - Security        Passwords for Operator Access/TL1/IPX,IP Filter table
6 - Trace          SNA trace

Enter command number:
_____ [DRM50-MSS] _____
Terminate input with <RET>                               ESC to exit
```

Note: the main menu is the reference point for all other forms that need to be completed.

6. **STOP. YOU HAVE COMPLETED THIS PROCEDURE.**

3.3 Back Up the *DynaStar 500'* (Base/Growth) Router Configuration File at the DRM Site

Purpose

Use this procedure to backup the configuration settings for the router at the DRM site.

When To Use

This procedure is performed whenever a new router has been installed and configured, or any new information is added to the configuration file.

Before You Begin

Required Tools

The following equipment is required to perform the procedure:

- PC with VT100 emulator software or a VT100 terminal connected to the network.
- Supervisor console permissions.

Required Conditions

The following conditions should exist before the procedure is performed:

- Log onto the Administrative Workstation (AW) console.
- Perform Procedure 3.1 Local Log on to the Networking Router, or Procedure 3.2 Remote Log on to the Networking Router, depending on location.

Required Information

Before beginning this procedure, you must have the IP address of the *DynaStar 500* router whose configuration files are to be backed up. This should be stored in the office records.

PROCEDURE

1. At the prompt (#), enter `cd /dynastar`

Response: #

Note: If the directory does not exist, execute the following command and repeat this step `:mkdir /dynastar`

2. Enter `pwd`

Response: /dynastar
#

3. Enter `tftp X`

X = IP address of router's *Ethernet*² port.

(For example, `tftp 10.10.9.254`)

Response: tftp

4. Enter `ascii`

Response: tftp>

1. Trademark of DYMEC, Inc.
2. Registered trademark of Xerox Corporation.

5. Enter get config
Response: Received XXXXX bytes in X seconds
tftp> (For example, Received 89740 bytes in 5.4 seconds
tftp>)
6. Enter binary
Response: tftp>
7. Enter get cnfgload.cmp
Response: Received XXXXX bytes in X seconds
tftp>
(For example, Received 7622 bytes in 4.6 seconds
tftp>)
8. Enter quit
Response: #
9. Enter ls -l
Response: total XXX
-rw-r--r-- 1 root other XXXX Jul 26 10:23 cnfgload.cmp
-rw-r--r-- 1 root other XXXX Jul 26 10:23 config
X = size of directory and files.
10. Perform Procedure 4.4, Backup Administrative Workstation Operating System.
11. **Stop. You have completed this procedure.**

3.4 Back Up The *DynaStar 500*¹ (Base/Growth) Router Configuration File at the Host Site

Purpose

Use this procedure to backup the configuration settings for the router at the *5ESS*[®] switch host site.

When To Use

This procedure is performed whenever a new router has been installed and configured, or any new information is added to the configuration file.

Before You Begin

Required Tools

The following equipment is required to perform the procedure:

- The ASM at the host site
- Supervisor console permissions

Required Conditions

Prior to performing this procedure, perform the following:

- Log onto the ASM and access the ASM GUI Switch Complex page. For more information on ASM procedures, see document 235–200–145, *OneLink Manager*[™] Administrative Services Module User's Guide.
- From the ASM GUI Switch Complex page, login to the ASM shell.

Required Information

Before beginning this procedure, you must have the IP address of the *DynaStar 500* router whose configuration files are to be backed up. This should be stored in the office records.

PROCEDURE

1. At the ASM prompt (asm0#), cd to the directory that contains the backup file of the host router to be updated:

```
Enter cd /varapp/dynastar/host_X
```

Where: X = 'a' if Host DynaStar Router 00 is being backed up

'b' if Host DynaStar Router 01 is being backed up

'c' if Host DynaStar Router 02 is being backed up

Response: asm0#

Note: : If the directory does not exist, execute the following commands and repeat step 1:

```
mkdir /varapp/dynastar
```

```
mkdir /varapp/dynastar/host_X
```

1. Trademark of DYMEC, Inc.

2. Enter pwd
Response: asm0# /varapp/dynastar/host_X
asm0#
Where: X = 'a' if Host DynaStar Router 00 is being backed up
'b' if Host DynaStar Router 01 is being backed up
'c' if Host DynaStar Router 02 is being backed up
3. Enter tftp X
where X is the IP address of *Ethernet*² port at the router
(For example, tftp 10.10.1.254.)
Response: tftp>
4. Enter ascii
Response: tftp>
5. Enter get config
Response: Received XXXXX bytes in X seconds
tftp>
X = variables indicating number of bytes per seconds.
6. Enter binary
Response: tftp>
7. Enter get cnfgload.cmp
Response: Received XXXX bytes in XXX seconds
tftp>
8. Enter quit
Response: asm0#
9. Enter ls -l
Response: total XXX
-rw-r--r-- 1 root other XXXX Jul 26 10:23 cnfgload.cmp
-rw-r--r-- 1 root other XXXXX Jul 26 10:23 config

Back up ASM to Tape. See document 235-200-145, *OneLink Manager*
Administrative Services Module User's Guide

2. Registered trademark of Xerox Corporation.

3.5 Restore the Configuration Settings for the *DynaStar 500*¹ (Base/Growth) Router at the DRM Site

Purpose

The following procedure restores the configuration settings for the router at the DRM site.

When to Use

The following procedure is used when restoring the original setting:

- after the router has been replaced, or
- due to a router that is malfunctioning.

Before You Begin

Required Conditions

This procedure requires:

- The faulty unit be replaced and all ports reconnected
- Use Procedure 3.1 Local Log on to the Networking Router, to display the Main Menu page of the unit.

Required Information

The following host router designations are used for this procedure:

- Base = host_a
- Growth = host_b
- Growth = host_c

To identify the IP address values, browse /dynastar/config from the DRM *UNIX*² console. The values are listed after the following variables:

- routerAdminIPAddress
- routerAdminIPMask
- Protocol is RIP II
- Encaps is Enet II

PROCEDURE

1. On the Main Menu page, type and enter 3 for Configuration.
Response: The Configuration Commands menu is displayed.
2. Type and enter 2 for Port.
Response: The Configure Port menu is displayed.
3. Type and enter 0 for *Ethernet*³.
Response: The *Ethernet* Interface Parameters page is displayed. See Figure 3.5-1.

1. Trademark of DYMEC, Inc.

2. Registered trademark in the United States and other countries licensed exclusively through X/Open Company Limited

3. Registered trademark of Xerox Corporation.

```
***Ethernet Interface Parameters***
Port: 0    On-board Ethernet    Last changed: 1-30-00
14:20:48
|- Press <RET> to toggle values -| |--Type in values. Max chars shown in ( ) --|
Port type: ethernet    Port name: Ethernet
(14)

MAC address: 00206100479e

Traffic types permitted to/from LAN
IP Routing:    Y
IPX Routing:   N
Ethernet Bridging: N
OSI Routing:   N
_____[ ]_____    Process selections (Y/N):Y
Use TAB & CURSOR keys to move among fields    Press ESC to abort command & exit
```

Figure 3.5-1 — Example of Ethernet Interface Parameters Screen With Field Values

4. On the *Ethernet* Interface Parameters page, specify the following information:
(Use TAB and Cursor keys to navigate among the fields.)
 - *IP Routing*: select Y (Use the return key to toggle between Y and N.)
 - *IPX Routing*: select N (Use the return key to toggle between Y and N.)
 - *Ethernet Bridging*: select N (Use the return key to toggle between Y and N.)
 - *OSI Routing*: select N (Use the return key to toggle between Y and N.)
5. Press the left arrow key.
Response: The cursor is positioned at *Process selections (Y/N)*.
6. Type and enter Y.
Response: The Configure Port menu is displayed.
If fields on the Ethernet Interface Parameters page were changed, the following messages are displayed.
Changes made for port 0
Config has changed: use CTRL-W to save
If fields on the Ethernet Interface Parameters page were not changed since the fields were already configured correctly, the following message is displayed.
No changes made for port 0
7. If changes were made to port 0, save the changes to flash memory by entering:
[ctr] w
Response: "Saving configuration to Flash..." is briefly displayed, and then the Configure Port menu is displayed.
If changes were not made to port 0, entering [ctr] w is not needed and will have no affect.
8. Press the [Esc] key to return to the Configuration Commands menu.
Response: The Configuration Commands menu is displayed.
9. Type and enter 3 for Router.
Response: The Router Commands menu is displayed.

10. Type and enter 5 for IP port information.

Response: The IP Port Information menu is displayed.

Exhibit 3.5-1 — IP Port Information Menu At DRM Site

```
***IP Port Information***
                                Last changed: 2-24-00 14:19:02
Port(s)   Interface             IP Address  IP Mask     |-Use RET to toggle|
          X.X.X.X              X.X.X.X    Protocol
Encaps
          0 Ethernet            10.10.1.254 255.255.255.0  RIP II  Enet II
          7 Sync/Async          0.0.0.0     0.0.0.0      RIP
          8 T1 to Host           0.0.0.0     0.0.0.0      RIP
          9 CSU/DSU chan 2      0.0.0.0     0.0.0.0      RIP
          201 - 204 QUAD card    0.0.0.0     0.0.0.0      RIP
          301 - 323 BRI         0.0.0.0     0.0.0.0      RIP
          351 - 374 Trunk 3/2  0.0.0.0     0.0.0.0      RIP
          600 - 631 Virtual X.25 *
```

11. At the IP Port Information menu, enter the following information:

(Use TAB and Cursor keys to navigate the menu.)

- *IP Address*, enter *Ethernet* Port IP Address of the router at the DRM site. (For example, enter 10.10.9.254 for Remote Router 1 configured to DRM 1)
- *IP Mask*, enter *Ethernet* Port SubNet Mask of the router at the DRM site. (For example, 255.255.255.0)

12. Press the left arrow key repeatedly until the cursor is positioned at the *Process IP Addresses (Y/N):* prompt.

13. Type and enter Y.

Response: The Router Commands menu is displayed with the message
Config has changed: use CTRL-W to save

14. Save the changes to flash memory by entering:

[ctrl] w

Response:

Saving configuration to Flash...

is briefly displayed, and then disappears when the save to flash memory has completed.

15. At the MCC console, login to the DRM *UNIX* shell.

Response:

#

16. Use the ping command to verify connectivity between the DRM and the Remote Router.

The format of the ping command is:

ping <IP address of the Remote Router>

Response:

<IP address of the Remote Router> is alive.

- If the ping command fails, **seek technical support.**
17. Type and enter `cd /dynastar`
Response:
 #
18. Type and enter `pwd`
Response:
 /dynastar
19. Type and enter `ls -l`
Response:
 total XXX
 -rw-r--r-- 1 root other XXXX Jul 26 10:23 cnfgload.cmp
 -rw-r--r-- 1 root other XXXXX Jul 26 10:23 config
20. Type and enter:
`tftp X`
Where: X = IP address of *Ethernet* port at the router. (For example, `tftp 10.10.9.254`)
Response:
 tftp>
21. Type and enter:
`binary`
Response: tftp>
22. Type and enter:
`put cnfgload.cmp`
Response:
 Sent XXXX bytes in XXX seconds
 tftp>
23. Type and enter:
`quit`
Response:
 #
24. On the Supervisor Console, display the Main Menu page if it is not already displayed:
- If the * prompt is displayed, type and enter 9999 at the * prompt to display the DynaStar Supervisor page. Continue with the steps below indicating what to do if the DynaStar Supervisor page is displayed.
 - If the DynaStar Supervisor page is displayed:
 - a. Type and enter `secret` (or the password set for your office) at the *Enter Password:* prompt.
Response:
The Supervisor Console Types information appears.

- b. Type and enter 2 (for VT100 or ANSI compatible) at the *Enter Console Type:* prompt.

Response:

The Main Menu page is displayed.

- If one of the other menu pages is displayed, press the [Esc] key repeatedly until the Main Menu page is displayed.
25. On the Main Menu page, type and enter 4 for System functions.
Response: The System Commands menu is displayed.
 26. Type and enter 6 to Reinitialize.
Response: The Reinitialize page is displayed.
 27. Type and enter `secret` (or the password set for your office) at the *Enter Current Password:* prompt.
Response: While the Router is reinitializing, the Router executes power-on self tests which output status messages onto the Supervisor Console, and cause the LEDs on the front of the Router to go through a series of changes. The initial color of the LEDs are yellow/orange, which turn to red, briefly flash to green, and then completely turn off.
At the conclusion of the power-on self testing, the top row of LEDs light up on the Router, and the DynaStar Supervisor page is displayed on the Supervisor Console.
 28. After the *DynaStar 500* initializes, the unit should be active. If there is no other problem, the link from the ASM to the DRM should restore. If not, **seek technical support** .
 29. **STOP. YOU HAVE COMPLETED THIS PROCEDURE.**

3.6 Restore the Configuration Settings for the *DynaStar 500'* (Base/Growth) Router at the *5ESS*[®] Switch Host Site

Purpose

The following procedure restores the configuration settings for the router at the *5ESS* Switch Host site.

When to Use

The following procedure is used when restoring the original setting:

- after the router has been replaced, or
- due to a router that is malfunctioning.

Before You Begin

Required Conditions

This procedure requires:

- The faulty unit be replaced and all ports reconnected.
- Use Procedure 3.1, "Local Log on to the Networking Router" to display the Main Menu page of the unit.

Required Information

The following host router designations are used for this procedure:

- Base = host_a
- Growth = host_b
- Growth = host_c

To identify the IP address values, browse `/varapp/dynastar/host_X/config` from the *ASM UNIX*² console.

Where: X = a, b, or c, depending on the Host Router.

The values are listed after the following variables:

- routerAdminIPAddress
- routerAdminIPMask
- Protocol is RIP II
- Encaps is Enet II

PROCEDURE

1. On the Main Menu page, type and enter 3 for Configuration.
Response: The Configuration Commands menu is displayed.
2. Type and enter 2 for Port.
Response: The Configure Port menu is displayed.

1. Trademark of Dynastar, Inc.
2. Registered trademark in the United States and other countries licensed exclusively through X/Open Company Limited

3. Type and enter 0 for *Ethernet*³

Response: The *Ethernet* Interface Parameters page is displayed. See Figure 3.5-1

4. On the *Ethernet* Interface Parameters page, specify the following information: (Use TAB and Cursor keys to navigate among the fields.)

- *IP Routing*:, select Y (Use the return key to toggle between Y and N.)
- *IPX Routing*:, select N (Use the return key to toggle between Y and N.)
- *Ethernet Bridging*, select N (Use the return key to toggle between Y and N.)
- *OSI Routing*, select N (Use the return key to toggle between Y and N.)

5. Press the left arrow key.

Response: The cursor is positioned at *Process selections (Y/N)*.

6. Type and enter Y.

Response: The Configure Port menu is displayed.
If fields on the Ethernet Interface Parameters page were changed, the following messages are displayed.

```
Changes made for port 0
Config has changed: use CTRL-W to save
If fields on the Ethernet Interface Parameters page
were not changed since the fields were already
configured correctly, the following message is
displayed.
No changes made for port 0
```

7. If changes were made to port 0, save the changes to flash memory by entering [ctrl] w

Response: Saving configuration to Flash...

is briefly displayed, and then the Configure Port menu is displayed.

If changes were not made to port 0, entering [ctrl] w is not needed and will have no affect.

8. Press the [Esc] key to return to the Configuration Commands menu.

Response: The Configuration Commands menu is displayed.

9. Type and enter 3 for Router.

Response: The Router Commands menu is displayed.

10. Type and enter 5 for IP port information.

Response: The IP Port Information menu is displayed. See Figure below for an example of the menu with the field values.

3. Registered trademark of Xerox Corporation.

Exhibit 3.6-1 — IP Port Information Menu At Host Site

```
***IP Port Information***
                                Last changed: 2-24-00 14:19:02
Port(s)      Interface      IP Address  IP Mask    I-Use RET to toggle|
              X.X.X.X      X.X.X.X
Encaps
0 Ethernet   10.10.1.254 255.255.255.0 RIP II  Enet II
7 Sync/Async 0.0.0.0     0.0.0.0    RIP
8 T1 to Host 0.0.0.0     0.0.0.0    RIP
9 CSU/DSU chan 2 0.0.0.0    0.0.0.0    RIP
201 - 204 QUAD card 0.0.0.0    0.0.0.0    RIP
301 - 323 BRI 0.0.0.0     0.0.0.0    RIP
351 - 374 Trunk 3/2 0.0.0.0    0.0.0.0    RIP
600 - 631 Virtual X.25 *
```

11. At the IP Port Information menu, enter the following information: (Use TAB and Cursor keys to navigate the menu.)
 - *IP Address*, enter *Ethernet* Port IP Address of the router at the host site. (For example, enter 10.10.1.254 for host_a)
 - *IP Mask*, enter *Ethernet* Port SubNet Mask of the router at the Host site. (For example, 255.255.255.0)
12. Press the left arrow key repeatedly until the cursor is positioned at the *Process IP Addresses (Y/N):* prompt. .
13. Type and enter Y.
Response: The Router Commands menu is displayed with the following message
Config has changed: use CTRL-W to save
14. Save the changes to flash memory by entering [ctrl] w
Response:
Saving configuration to Flash...
is briefly displayed, and then disappears when the save to flash memory has completed.
15. Use an approved web browser to login to the ASM GUI. Enter the machine name or IP address in the web browser URL box.
Response: The Login Page displays.
16. Enter Login and Password.
Response: The Message of the Day page displays.
17. Select the **Continue** button.
Response: The *OneLink Manager*[™] Page displays.
18. Select the Switching Components icon.
Response: The Switching Components Page displays.
19. Click on the ASM Cabinet.
Response: The ASM Cabinet Page displays.

20. Click on the ASM Unit.

Response: The ASM Page displays.

21. Right Click on the **Cut Through** button and select *Open Telnet to ASM* option from the drop down menu.

Response: A separate window opens containing the ASM *UNIX* shell.

22. Login to the ASM *UNIX* Shell.

Response:

```
asm0#
```

23. Use the ping command to verify connectivity between the ASM and the Host Router.

The format of the ping command is:

```
ping <IP address of the Host Router>
```

Response:

```
<IP address of the Host Router> is alive
```

If the ping command fails, **seek technical support**.

24. Type and enter `cd /varapp/dynastar/X`

Where: X = host_a, host_b, or host_c

Response:

```
asm0#
```

25. Type and enter `pwd`

Response:

```
/varapp/dynastar/X
```

Where: X = host_a, host_b, or host_c

26. Type and enter `ls -l`

Response:

```
total XXX
-rw-r--r-- 1 root other XXXX Jul 26 10:23 cnfgload.cmp
-rw-r--r-- 1 root other XXXX Jul 26 10:23 config
```

27. Type and enter `tftp X`

Where: X = the IP address of *Ethernet* port at the router

(For example, `tftp 10.10.1.254`)

Response:

```
tftp>
```

28. Type and enter `binary`

Response:

```
tftp>
```

29. Type and enter `put cnfgload.cmp`

Response:

```
Sent XXXX bytes in XXX seconds  
tftp>
```

X varies according to the configuration of the router.

30. Type and enter `quit`

Response:

```
asm0#
```

31. On the Supervisor Console, display the Main Menu page if it is not already displayed:

- If the `*` prompt is displayed, type and enter `9999` at the `*` prompt to display the DynaStar Supervisor page. Continue with the steps below indicating what to do if the DynaStar Supervisor page is displayed.
- If the DynaStar Supervisor page is displayed:
 - a. Type and enter `secret` (or the password set for your office) at the *Enter Password:* prompt.

Response:

The Supervisor Console Types information appears.

- b. Type and enter `2` (for VT100 or ANSI compatible) at the *Enter Console Type:* prompt.

Response:

The Main Menu page is displayed.

- If one of the other menu pages is displayed, press the `[Esc]` key repeatedly until the Main Menu page is displayed.

32. On the Main Menu page, type and enter `4` for System functions.

Response: The System Commands menu is displayed.

33. Type and enter `6` to Reinitialize.

Response: The Reinitialize page is displayed.

34. Type and enter `secret` (or the password set for your office) at the *Enter Current Password:* prompt.

Response: While the Router is reinitializing, the Router executes power-on self tests which output status messages onto the Supervisor Console, and cause the LEDs on the front of the Router to go through a series of changes. The initial color of the LEDs are yellow/orange, which turn to red, briefly flash to green, and then completely turn off.

At the conclusion of the power-on self testing, the top row of LEDs light up on the Router, and the DynaStar Supervisor page is displayed on the Supervisor Console.

35. After the *DynaStar*⁴ initializes, the unit should be active. If there is no other problem the link from the ASM to the DRM should restore. If not, **seek technical support** .

4. Trademark of DynaStar, Inc.

36. STOP. YOU HAVE COMPLETED THIS PROCEDURE.

3.7 Configure the Router to Support Serial Asynchronous Interface (SAI) at the DRM Site

OVERVIEW

The following procedure sets up the configuration of the *DynaStar 500*¹ to allow a vt100 terminal to connect to a port at a DynaStar unit that is remote from the DRM to provide the user with the same access to RC/V and STLWS as any terminal set up for OAM&P.

Remote output channels can be provisioned for:

- traffic
- office record
- balance

Purpose

The following procedure configures the DRM site router to support Serial Asynchronous Interface (SAI).

When to Use

The following procedure should be used to provide access to the DRM SAI ports by:

- Collecting the data from the dedicated serial ports on the *DynaStar 500* through Telnet, or
- Collecting the data from the SAI ports at a dedicated VT100 terminal.

Before You Begin

Required Conditions

The following conditions should exist before the procedure is performed:

- The router is connected to the network.
- A terminal (laptop computer or VT100 terminal) is connected to the network.
- Use Procedure 3.1, Local Log on to the Networking Router, to get to the main menu of the unit.

Select the terminal application and SAI port. Follow the specific terminal's growth procedures:

- 8.3, Perform STLWS Growth
- 8.4, Perform RC/V Terminal Growth
- 8.11, Perform TDMS/EADAS Data Link Growth

Required Materials

A cable is needed to connect the SAI port on the Administrative Workstation to the port of the networking router at the DRM site:

- 5 ft. cable (COM CODE: 408355543), or

1. Trademark of DYMEC, Inc.

- 10 ft. cable (COM CODE: 408355535)

to connect SAI-0, ports 2–7 and SAI-1, ports 0–7 (*Netra* t 1120 and *Netra*² 20) or ports 0–5 (*Netra* 240) to remote *DynaStar*³ port 102 or 103 through 116.

PROCEDURE

3.7.1 Program the Port of the Router at the DRM Site for PAD Access

1. At the main menu, Enter 2 for port.

Response: The Configure Port menu is displayed.

2. Enter 1 for the port number on the 16–port card.

Response: The Configure Port menu is displayed.

3. At the PAD port configuration menu, enter the following information: (Use the <Tab> and <cursor> keys to navigate the menu.)

- At **port name**, enter RC/V, STLWS, Traffic, Office Records, or Balance.
- At *Connection mode*, enter DTE (Press the return key to change.)
- At *DSS signal*, enter Ignore (Press the return key to change.)
- At *Port X.121 address*, enter 3000 plus the port number that is chosen in the previous step.

For example, if 102 is entered in the previous step, then enter 3102.

- At *X.28 Profile*, enter 85(10).

See Figure 3.7-1 for an example of the PAD Port Configuration menu with the field values.

```
*** PAD Port Configuration ***
Port: 203 IS-232 Last changed: 6-1-00 11:05:56
|- Press <RET> to toggle values -| |--Type in values. Max Chars shown in () --|
Port type: PAD Port name: RC/V (14)

Connection mode: DTE Port X.121 address: 3203 (15 BCD)
Modem speed: 9600 Baud X.121 sub-address: (2 BCD)
Parity: 7-EVEN Use sub-address in calling DTE address: N
DSS flow control: N Inactivity timer: 0 (0-disable, 1-30 min)
Call address field: NONE

NUI Required: N Enter ? <RET> for profile list
Mnemonic Type: NORMAL X.28 profile: 85(10)
Port signals option: TERM x.29 profile: 00(00)
Waiting for DSS: N (fixed) EPOS profile: 00
Set M-bit on full Pkt: N Enter Data Forwarding Char: (00 - 7F)
Max port forward limit: NONE Logoff Script: 0
Autoconnect: N
Double Break: N
Drop DSS: N X.28 command: (32)
DSS signal: IGNORE

_____[DRM50-ROUTER]_____, Process selections (Y/N): Y
Use TAB & CURSOR keys to move among fields Press ESC to abort command & exit
```

Figure 3.7-1 — PAD Port Configuration Menu with Sample Field Input

2. Trademark of Sun Microsystems, Inc.
3. Trademark of ACT Networks Inc.

4. Press the left arrow key twice.
Response: The cursor is positioned at Process selections (Y/N).
5. Enter Y.
6. Press the <Esc> key.
Response: The main menu is displayed.
7. At the main menu, enter 3 for configuration.
Response: The Configuration Commands menu is displayed.
8. Enter 6 for asynchronous services.
Response: The Access Server Commands menu is displayed.
9. Enter 5 for Async Services.
Response: The Async Service menu is displayed.
10. At the Async Services menu, enter the following information: (Use the <Tab> and <cursor> keys to navigate the menu.)
 - At **Service type**, enter X.25-Out Stream
 - At **X.121 address**, enter 3000 + <port #>
For example, if 102 was entered, then enter 3102.
 - At **X.3 Profile**, enter 85.
 - At **Socket Number**, enter 3000 + <port #> .
For example, if 102 was entered, then enter 3102.
 - At **IP address**, enter the *Ethernet*⁴ IP address of the router at the DRM site.
For example, 10.10.9.254See Figure 3.7-2 for an example of the Async Services menu with values input.

```
*** Async Services ***
|- Press <RET> to toggle values -| |-- Type in values. Max chars shown in () --|
Service name: Remote RCV (15)
Service type: X25-Out Stream X.121 address: 3203 (15 BCD)
CUG(0-99)
Socket Number: 3203 X.3 Profile: 85(10) DRM (name or number)
IP address: 10.10.9.254
Telnet command: -N -Q -H FB03 (23)
TCP idle timer: OFF (1-255 min)
Call User Data: (16 Hex)

_____[DRMXX-ROUTER]_____| Process selections (Y/N): Y
Use <CTRL-D> to delete entry
Use TAB & CURSOR keys to move among fields Press ESC to abort command & exit
```

Figure 3.7-2 — The Async Services Menu with Sample Field Values

4. Registered trademark of Xerox Corporation.

Note: Each X.121 address must be unique for each *DynaStar* box. Therefore, it is recommended that a naming convention be used so that the address for the first DRM (node #=1) port 102, the X.121 address will be 3102. $(3+1-1) * 1000 + 102 = 3102$.

For the second DRM, same port, the address will be 4102.

$(3+2-1) * 1000 + 102 = 4102$.

The limit for X.121 address is 65555.

11. (Enter to access the terminal through Telnet only) At **Telnet command**, enter -N
-Q -H FB03
12. Press the left arrow key twice.
Response: Cursor is displayed at Process selections (Y/N).
13. Enter Y.
14. To save to flash, Enter: <ctrl>w
Response: The settings are saved to memory.
15. Press the <Esc> key until the main menu appears.
Response: The main menu is displayed.
16. Enter <ctrl>].
Response: Telnet>
17. Enter quit.
Response: Connection Closed.
18. Execute Procedure 3.3.

3.7.2 Program the Serial Port of the OS Router for PAD Access

Note: Use the following procedure only for remote terminal access to DRM SAI Port Devices.

1. At the main menu, enter 3 for configuration.
Response: The Configuration Commands menu is displayed.
2. Enter 6 for Async Services.
Response: The Access Server Commands menu is displayed.
3. Enter 2 for PAD profiles.
Response: The PAD Profiles menu is displayed.
4. At **85(10)**, enter DRM.
5. At **Enter profile number to view/change X.3 parameters**, enter 85.
Response: The X.3 Parameter Values menu is displayed.

```

*** X.3 Parameter Values ***
Profile 85(10)DRM      Enter value      Permitted values
1: PAD recall         0              0-no escape, 1-DLE, 32-126 define char
2: PAD echo           0              0-no echo, 1-echo
3: Data forwarding chars 0              0, 2, 4, 8, 16, 32, 64, 128, 3-255
4: Idle timer         5              0-disabled, 1-255 twentieths of second
5: Flow control by PAD 0              0-no use of XON/XOFF, 1-use XON/XOFF
6: PAD services signals 0              0-none, 1-no prompt, 5-prompt &*, 8-15
7: Break handling     0              0, 1, 2, 5, 8, 21
8: Discard output     0              0-normal delivery, 1-discard
9: Padding after CR   0              0-none, 1-255 padding characters
10: Line folding       0              0-none, 1-255 graphic characters per line
12: Flow control of PAD 0              0-no use of XON/XOFF, 1 use XON/OFF
13: LF after CR        0              0, 1, 4, 5, 6, 7
14: Padding after LF   0              0-none, 1-255 padding characters
15: Editing            0              0-none, 1-editing in data transfer
16: Character delete   0              0-126 IA5 character, 127-DEL
17: Line delete        0              0-23 & 25-127 IA65 character, 24-CAN
18: Line display       0              0-17 & 19-127 IA5 character, 18-DC2
19: Editing signals    0              0-none, 1-printing, 2-display terminal
20: Echo mask          0              0, 2, 4, 8, 16, 32, 64, 128, 3-255
21: Parity treatment   0              0-none, 3-checking and generation
22: Page wait          0              0-disabled, 1-255 LFs
Press ESC to abort command & exit      Process selections (y/N): Y

```

Figure 3.7-3 — Example X.3 Parameter Values Screen with Sample Field Values

6. Enter 5 for the Idle timer parameter value and 0 for all the remaining parameter.
7. Press the arrow key until the cursor is positioned at Process selections (Y/N)
8. Enter Y.
Response: The Configure Port menu is displayed.
9. Press the <Esc> key until the main menu appears.
Response: The main menu is displayed.
10. At the main menu, enter 3 for configuration.
Response: The Configuration Commands is displayed.
11. Enter 2 for port.
Response: The Configure Port menu is displayed.
12. Enter 1 for 16-port card.
Response: The Configure Port menu is displayed.
13. Enter the port number of the port to be connected.

The last number of the port number is the slot number on the back of the *DynaStar*. For example, if you want to connect to port 2, choose the port number that ends with 2. For example: 102.

Response: The PAD port configuration menu is displayed.
14. At the PAD port configuration menu, enter the following information: (Use the <Tab> and <cursor> keys to navigate the menu.)
 - At **Port type:**, enter PAD
 - At **Port name**, enter Remote RC/V.

- At **Connection mode**, enter DCE (Use the return key to toggle.)
- At **Autoconnect**, enter Y-DSS (Use the return key to toggle.)
- At **DSS signal**, enter IGNORE (Use the return key to toggle.)
- At **Port X.121 address**, enter 3000 plus the port number that is chosen in the previous step.

For example, if 102 is entered in the previous step, then enter 3102.

- At **X.28 Profile**, enter 85(10).
- At **X.28 command**, enter 3000 plus the port number that is chosen in the previous step.

For example, if 203 is entered for the previous step, then enter 3203.

Response: See Figure 3.7-4 for an example of PAD Port Configuration Menu with sample field values.

```
*** PAD Port Configuration ***
Port: 102 IS-232          Last changed: 6-1-00 13:39:23
|- Press <RET> to toggle values -| |--Type in values. Max Chars shown in () --|
Port type: PAD          Port name: Remote RC/V          (14)

Connection mode:      DCE          Port X.121 address: 3102          (15 BCD)
Modem speed:         9600 Baud    X.121 sub-address:             (2 BCD)
Parity:              7-EVEN      Use sub-address in calling DTE address: N
DSS flow control:    N           Inactivity timer: 0           (0-disable, 1-30 min)
Call address field:  NONE

NUI Required:        N           Enter ? <RET> for profile list
Mnemonic Type:       NORMAL      X.28 profile: 85(10)
Port signals option: TERM        X.29 profile: 00(00)
Waiting for DSS:     N (fixed)   EPOS profile: 00
Set M-bit on full Pkt: N         Enter Data Forwarding Char: (00 - 7F)
Max port forward limit: NONE     Logoff Script: 0
Autoconnect:         N           Retry timer: 10
Double Break:        N          Retry attempts: 1
Drop DSS:            N           X.28 command: 3203          (32)
DSS signal:          IGNORE

_____[OS_ROUTER]____ Process selections (Y/N): Y
Use TAB & CURSOR keys to move among fields Press ESC to abort command & exit
```

Figure 3.7-4 — PAD Port Configuration for Remote RC/V with Sample Values

15. Press the left arrow key twice.

Response: The cursor is positioned at Process selections (Y/N).

16. Enter Y.

Response: The Configure Port menu is displayed.

17. Hold down the Ctrl key and press the w key.

Response: The settings are saved to flash.

18. Press the <Esc> until the main menu appears.

Response: The main menu is displayed.

19. At the main menu, enter 3 for configuration.

Response: The Configuration Commands menu is displayed.

20. Enter 6 for Access Services.
Response: The Access Server Commands menu is displayed.
21. Enter 5 for Async service.
Response: The Async Service Names menu is displayed.
22. At the Async Service Names menu, enter the following information: (Use the <Tab> and <cursor> keys to navigate the menu.)
 - At **service type**, enter X.25-In (Use the return key to change.)
 - At **X.121 address**, enter $(3+\text{node number}-1) * 1000 + \text{port \#}$ For example, $(3+2-1) * 1000 + 102$ is 4102
Note: To identify the node number, identify the order in which the DRMs were added to the network. For example if the DRMs are sequentially added, DRM 1 is node 1, DRM 2 is node 2, and so on.
 - At **X.3 Profile**, enter 85.
 - At **Socket Number**, enter $(3+\text{node \#} - 1) * 1000 + \text{port \#}$.
 - At **IP address**, enter the *Ethernet* IP address of the router at the DRM site.
For example, 10.10.9.254
23. Press the left arrow key twice.
Response: Cursor is displayed at Process selections (Y/N).
24. Enter Y.
Response: The Async Service Names menu is displayed.
25. To save to flash, enter <ctrl>w
Response: The settings are saved to memory.
26. Press <Esc> until the main menu appears.
Response: The main menu is displayed.
27. **STOP. YOU HAVE COMPLETED THIS PROCEDURE.**

3.8 Set up the High Speed Interface to send NFM/SCC data to the 5ESS[®] Switch Host Site

OVERVIEW

The Network Fault Management (NFM) Operational Support System is located near the host 5ESS Switch. The DRM's total network management (TNM) traffic is routed back to the host over the TCP-IP network. The connection to the OSS router may be *Ethernet*¹ from the *Cajun*² P333T from one of the Host routers. The remote router and the OSS router must support X.25 over TCP-IP (XOT) functionality. At the DRM, the High Speed Interface (port 2) is connected to a synchronous port 203 on the remote router. The remote router and OSS router are programmed with the destination IP address and port #.

Purpose

Use this procedure to provide access to DRM high speed interface ports by connecting the ports to the customer operational support services (OSS).

When to Use

The following procedure is used to configure high speed interface to the OSS:

- after the router has been replaced, or
- due to a router that is malfunctioning.

Before You Begin

Required Conditions

The following conditions should exist before the procedure is performed:

- Perform Procedure 8.9, SCC Data Link Growth
- Verify that the router is connected to the network.
- Verify that a terminal (laptop computer or VT100 terminal) is connected to the network.
- Use Procedure 3.1 to get to the main menu of the unit.
- To configure the High Speed Interface, access:
 - a control display cut-through window, or
 - an MCC terminal.

PROCEDURE

3.8.1 Configure the Router at the DRM Site

3.8.1.1 Remotely Log on to the Networking Router

1. Perform Procedure 3.2, to log on to the router locally.

1. Registered trademark of XEROX Corporation.

2. Trademark of AVAYA Communications, Inc.

3.8.1.2 Assign the High Speed Port on the Router at the DRM site

1. Enter 3 for configuration.
Response: The Configuration Commands menu is displayed.
2. Enter 2 for port.
Response: The Configure Port menu is displayed.
3. Enter 2 for Quad-Card.
Response: The Configure Port menu is displayed.
4. Enter 203
Response: The PPP Synchronous Port Configuration menu is displayed.
5. At *Port type*, enter X.25 line. (Use the return key to change.)
Response: The X.25 Port Configuration menu is displayed.
6. At the x.25 Port Configuration Screen, enter the following information: (Use the arrow keys to navigate the screen)
 - At *Port name*, enter SCC
 - At *Connection Mode*, enter DCE (Use the return key to change.)
 - At *Line Speed*, enter 9.6 Kbps (Use the return key to change.)
 - At *X.25 mode*, enter DCE (Use the return key to change.)
 - At *Max Packet size*, enter 256 (Use the return key to change.)
 - At *IPX Routing*, enter N (Use the return key to change.)
 - At *Ethernet Routing*, enter N (Use the return key to change.)
 - At *Permanent / Number of VCs*, enter 7
7. Press the left arrow twice.
Response: The cursor is positioned at Process Selections (Y/N).
8. Enter Y
Response: The Configure Port menu is displayed.
9. To save to flash, Enter : <ctrl>w
10. Press the esc key until the main menu is displayed.
Response: The main menu is displayed.

3.8.1.3 Assign XOT and define the remote IP Address, port and LCN

1. Enter 3 for configuration.
Response: The Configuration Commands menu is displayed.
2. Enter 10 for X.25.
Response: The X.25 Parameters menu is displayed.
3. Enter 5 for XOT switching table.
Response: The XOT PVC SCV Switching Table is displayed.

4. For each of the 7 LCNs, enter the following information: (Use the arrow keys to navigate the screen)
 - At *Service*, enter PVC/XOT (Use the return key to change.)
 - At *LOCAL PORT #*, enter 203
 - At *LOCAL LCN #*, enter 1, 2, 3, 4, 5, 6, or 7
 - At *REMOTE PORT #*, enter the port number for the OS Router that handles SCC traffic.
 - At *REMOTE LCN #*, enter 1, 2, 3, 4, 5, 6, or 7
 - At *REMOTE IP Address*, enter the IP Address for the OS Router that handles SCC traffic
5. Press the left arrow key twice.
Response: The cursor is positioned at Process Selections (Y/N).
6. Enter Y.
7. Hold down the Ctrl key and press the W key.
8. Hold down the Ctrl key and press the] key.
9. Enter quit

3.8.2 At the Host Site, Connect the OSS Router to the Router at the DRM Site

3.8.2.1 Connect the SCC Router at the DRM Site to the OSS Router

Note: If the remote OS router is not to be used to set up a permanent connection for IP routing from a router at the DRM site, use local procedures instead of the following procedure to set up the permanent connection for IP routing between the remote router and the OS router.

1. Enter 3 for configuration.
Response: The Configuration Commands menu is displayed.
2. Enter 2 for port.
Response: The Configure Port menu is displayed.
3. Enter the port number to which you wish to connect.
Note: The last number of the port number is the slot number on the back of the DynaStar. If you want to connect to port 2, choose the port number that ends with 2. For example: 102.
Response: The PPP Synchronous Port Configuration menu is displayed.
4. At *Port type*, enter X.25 line. (Use the return key to change.)
Response: The X.25 Port Configuration menu is displayed.
5. At the X.25 Port Configuration menu, enter the following information: (Use the arrow keys to navigate the screen)
 - At *Port name*, enter NFM.
 - At *Connection Mode*, enter DTE (Use the return key to change.)

- At *Line Speed*, enter 2.4 Kbps (Use the return key to change.)
 - At *X.25 mode*, enter DTE (Use the return key to change.)
 - At *Max Packet size*, enter 256 (Use the return key to change.)
 - At *IPX Routing*, enter N.
 - At *Ethernet Routing*, enter N (Use the return key to change.)
 - At *Permanent / Number of VCs*, enter 7.
6. Press the left arrow twice.
Response: The cursor is positioned at Process Selections (Y/N).
7. Enter Y
Response: The Configure Port menu is displayed.
8. Hold down the Ctrl key and press the W key.
9. Enter <Esc> to return to the main menu.
Response: The main menu is displayed.

3.8.2.2 Assign XOT and Define the Remote IP Address, Port and LCN

1. Enter 3 for configuration.
Response: The Configuration Commands menu is displayed.
2. Enter 10 for X.25.
Response: The X.25 Parameters menu is displayed.
3. Enter 5 for XOT switching table.
Response: The XOT PVC SCV Switching Table is displayed.
4. For each of the 7 LCNs, enter the following information:
- At *Service*, enter PVC/XOT (Use the return key to change.)
 - At *LOCAL PORT #*, enter the port number for the OS Router that handles SCC traffic.
 - At *LOCAL LCN #*, enter 1, 2, 3, 4, 5, 6, or 7
 - At *REMOTE PORT #*, enter 203
 - At *REMOTE LCN #*, enter 1, 2, 3, 4, 5, 6, or 7
 - At *REMOTE IP Address*, enter the IP Address for the OS Router that handles SCC traffic
5. Press the left arrow key twice.
Response: The cursor is positioned at Process Selections (Y/N).
6. Enter Y.
7. Hold down the Ctrl key and press the W key.
8. Hold down the Ctrl key and press the] key.
9. Enter quit

10. Perform Procedure 3.3, Back up the *DynaStar 500*³

3. Trademark of DYMEC, Inc.

3.9 Set up the High Speed Interface to Send EADAS Data to the Host Site

Purpose

The following procedure is used to set up the High Speed Interface to send EADAS data to the Host Site.

Reason to Perform

The following procedure should be used to provide access to DRM High Speed Interface ports by connecting the High Speed Interface ports to the customer operational support services (OSS).

Before You Begin

The following factors must be considered before you begin the procedure:

Required Conditions

The following conditions should exist before the procedure is performed:

- Verify that the router is connected to the network.
- Verify that a terminal (laptop computer or VT100 terminal) is connected to the network.

PROCEDURE

3.9.1 Access the High Speed Interface

1. Access the High Speed Interface from:
 - a control display cut-through window, or
 - an MCC.

3.9.2 Install the EADAS Router at the DRM Site

1. Perform Procedure 8.11 to grow TDMS/EADAS Data Links and connect the High Speed Interface port to the router port cable.

3.9.3 Configure the Router at the DRM Site

3.9.3.1 Assign the High Speed Interface Port on the Router at the DRM site

1. Perform Procedure 3.2 to remotely log on to the networking router.
2. Enter 3 for configuration.
Response: The Configuration Commands menu is displayed.
3. Enter 2 for port.
Response: The Configure Port menu is displayed.
4. Enter 2 for Quad-Card.
Response: The Configure Port menu is displayed.
5. Enter 204
Response: The PPP Synchronous Port Configuration menu is displayed.

6. At *Port type*, enter X.25 line. (Use the return key to change.)
Response: The X.25 Port Configuration menu is displayed.
7. At the x.25 Port Configuration Screen, enter the following information: (Use the arrow keys to navigate the screen)
 - At *Port name*, enter EADAS
 - At *Connection Mode*, enter DCE (Use the return key to change.)
 - At *Line Speed*, enter 64 Kbps (Use the return key to change.)
 - At *X.25 mode*, enter DCE (Use the return key to change.)
 - At *Max Packet size*, enter 256 (Use the return key to change.)
 - At *IPX Routing*, enter N (Use the return key to change.)
 - At *Ethernet Routing*, enter N (Use the return key to change.)
 - At *Permanent / Number of VCs*, enter 3
8. Press the left arrow twice.
Response: The cursor is positioned at Process Selections (Y/N).
9. Enter Y
Response: The Configure Port menu is displayed.
10. To save to flash, Enter <ctrl>w.
11. Press the <Esc> to return to the main menu.
Response: The main menu is displayed.

3.9.3.2 Assign XOT and define the remote IP Address, port and LCN

1. Enter 3 for configuration.
Response: The Configuration Commands menu is displayed.
2. Enter 10 for X.25.
Response: The X.25 Parameters menu is displayed.
3. Enter 5 for XOT switching table.
Response: The XOT PVC SCV Switching Table is displayed.
4. For each of the 7 LCNs, enter the following information: (Use the arrow keys to navigate the screen)
 - At *Service*, enter PVC/XOT (Use the return key to change.)
 - At *LOCAL PORT #*, enter 204
 - At *LOCAL LCN #*, enter 1, 2, 3, 4, 5, 6, or 7
 - At *REMOTE PORT #*, enter the port number for the OS Router that handles EADAS traffic.
 - At *REMOTE LCN #*, enter 1, 2, 3, 4, 5, 6, or 7
 - At *REMOTE IP Address*, enter the IP Address for the OS Router that handles EADAS traffic.

5. Press the left arrow key twice.
Response: The cursor is positioned at Process Selections (Y/N).
6. Enter Y.
7. Hold down the Ctrl key and press the W key.
8. Hold down the Ctrl key and press the] key.
9. Enter quit
10. Perform Procedure 3.3, Back up the *DynaStar 500*¹

3.9.4 At the Host Site, Connect the OSS Router to the Router at the DRM Site

3.9.4.1 Connect the EADAS to the OSS Router

Note: If the remote OS router is not to be used to set up a permanent connection for IP routing from a router at the DRM site, use local procedures instead of the following procedure to set up the permanent connection for IP routing between the remote router and the OS router

1. Enter 3 for configuration.
Response: The Configuration Commands menu is displayed.
2. Enter 2 for port.
Response: The Configure Port menu is displayed.
3. Enter the port number to which you wish to connect.
Note: The last number of the port number is the slot number on the back of the DynaStar.
If you want to connect to port 2, choose the port number that ends with 2. For example: 102.
Response: The PPP Synchronous Port Configuration menu is displayed.
4. At *Port type*, enter X.25 line. (Use the return key to change.)
Response: The X.25 Port Configuration menu is displayed.
5. At the X.25 Port Configuration menu, enter the following information: (Use the arrow keys to navigate the screen)
 - At *Port name*, enter EADAS.
 - At *Connection Mode*, enter DTE (Use the return key to change.)
 - At *Line Speed*, enter 64 Kbps (Use the return key to change.)
 - At *X.25 mode*, enter DTE (Use the return key to change.)
 - At *Max Packet size*, enter 256 (Use the return key to change.)
 - At *IPX Routing*, enter N.
 - At *Ethernet Routing*, enter N (Use the return key to change.)

1. Trademark of DYMEC, Inc.

- At *Permanent / Number of VCs*, enter 3.
- 6. Press the left arrow twice.
Response: The cursor is positioned at Process Selections (Y/N).
- 7. Enter Y
Response: The Configure Port menu is displayed.
- 8. Enter <Ctrl>w.
- 9. Press the <Esc> key until the main menu is displayed.
Response: The main menu is displayed.

3.9.4.2 Assign XOT and define the remote IP Address, port and LCN

1. Enter 3 for configuration.
Response: The Configuration Commands menu is displayed.
2. Enter 10 for X.25.
Response: The X.25 Parameters menu is displayed.
3. Enter 5 for XOT switching table.
Response: The XOT PVC SCV Switching Table is displayed.
4. For each of the 7 LCNs, enter the following information: (Use the arrow keys to navigate the screen)
 - At *Service*, enter PVC/XOT (Use the return key to change.)
 - At *LOCAL PORT #*, enter the port number for the OS Router that handles EADAS traffic.
 - At *LOCAL LCN #*, enter 1, 2, 3, 4, 5, 6, or 7
 - At *REMOTE PORT #*, enter 204
 - At *REMOTE LCN #*, enter 1, 2, 3, 4, 5, 6, or 7
 - At *REMOTE IP Address*, enter the IP Address for the OS Router that handles EADAS traffic
5. Press the left arrow key twice.
Response: The cursor is positioned at Process Selections (Y/N).
6. Enter Y.
7. Hold down the Ctrl key and press the W key.
8. Hold down the Ctrl key and press the] key.
9. Enter quit
10. Perform Procedure 8.11.7 to verify operations of TDMS/EADAS Data Link
11. Perform Procedure 8.11.8 to back up office dependent data.

3.10 Install the BRI to PRI to Back up the T1

OVERVIEW

The T1 facility can have a back up connection established when the T1 connection is unavailable. In order to back up the T1, a BRI is used at the remote site. One B-channel is used as a 64K backup channel when the T1 connectivity is lost. It does not provide the same throughput as a 1.544K T1 but allows for maintenance activities to take place. The BRI at remote site is a purchased by the customer. It must be a National ISDN BRI with CSD 64KB Clear capabilities on B-channel 1, a 10-digit CSD DN, and a SPID.

Purpose

Use this procedure to set up the BRI to PRI backup for the T1.

When to Use

The following procedure is used to provide a backup mechanism for the network when the T1 is not accessible.

To create a T1 backup for the network, each of the up to 15 BRI's and one PRI need to be configured. In this configuration, the PRI is located at the 5ESS[®] switch site and the BRI is located at each DRM site.

Before You Begin

The following factors must be considered before you begin the procedure:

Required Conditions

The following conditions should exist before the procedure is performed:

- Verify that the router is connected to the network.
- Verify that a terminal (laptop computer or VT100 terminal) is connected to the network.

PROCEDURE

3.10.1 Install the PRI at the Host Site

1. At the Host Site, Connect Router 00 to Port 301 and the MDF.

3.10.1.1 Assign Trunk type as T1 PRI

1. Enter 3 for configuration.
Response: The Configuration Commands menu is displayed.
2. Enter 2 for port.
Response: The Configure Port menu is displayed.
3. Enter 300 for PRI.
Response: The T1 Trunk Parameters menu is displayed.
4. Enter 1.
5. Enter the following information: (Use the arrow keys to navigate the screen.)
 - At *Trunk Type*, enter T1 PRI. (Use return key to change.)

- At *Trunk Name*, enter PRI
 - At *FrameType*, enter D4. (Use return key to change.)
6. Press the left arrow.
Response: The cursor is positioned at process selections (Y/N).
 7. Enter y.
 8. Press the esc key until the main menu is displayed.
Response: The main menu is displayed.

3.10.1.2 Assign Incoming Telephone Number for the PRI

1. Enter 3 for configuration.
Response: The Configuration Commands menu is displayed.
2. Enter 2 for port.
Response: The Configure Port menu is displayed.
3. Enter 300 for PRI.
Response: The T1 Trunk Parameters menu is displayed.
4. Enter 2 for Configure Incoming Telephone Number and SPIDs.
5. Enter the PRI access telephone number.
6. Press the left arrow.
Response: The cursor is positioned at process selections (Y/N).
7. Enter y.
8. Press the esc key until the main menu is displayed.
Response: The main menu is displayed.

3.10.1.3 Assign Router 00, PRI IP Addresses/Masks/Protocols

1. Enter 3 for configuration.
Response: The Configuration Commands menu is displayed.
2. Enter 3 for router.
Response: The Router Commands menu is displayed.
3. Enter 5 for IP Port Information.
Response: The IP Port Information menu is displayed.
4. At the IP Port Information menu, enter the following information: (Use the arrow keys to navigate the screen.)
 - At *IP Address*, enter the PRI IP Address.
 - At *IP mask*, enter the PRI port IP mask
 - At *Protocol*, enter RIP II. (Use the return key to change.)

5. Press the left arrow.
Response: The cursor is positioned at process selections (Y/N).
6. Enter Y.
7. Hold down the Ctrl key and press the w key.
Response: The settings are saved to flash.
8. Press the esc key until the main menu is displayed.
Response: The main menu is displayed.

3.10.2 Save the Configuration Files Remotely

3.10.2.1 Host Networking Router Configuration File Back Up Procedure

1. Perform Procedure 3.4, Backup The *DynaStar 500*¹ (Base/Growth) Router at the Host Site, to remotely save the configuration files.

3.10.2.2 Connect the Router to BRI Port 301 and the MDF

1. At the DRM site, connect the router to BRI port 301 and the MDF.

3.10.3 Program the BRI at the remote router

3.10.3.1 PPP Dial Entry to access the PRI

1. Enter 3 for configuration.
Response: The Configuration Commands menu is displayed.
2. Enter 1 for PPP Dial Directions.
Response: The PPP Dial Directions menu is displayed.
3. Press Return.
Response: The PPP Dial Directory Entry menu is displayed.
4. Enter the following information: (Use the arrow keys to navigate the screen.)
 - At the *Location Name*, enter BRI to Host.
 - At *ISDN Interface*, enter BRI
 - At *PhoneNumber*, enter the PRI Access telephone number.
 - At *IP Routing*, enter y (Use the return key to change.)
 - At the *Remote IP address*, enter the PRI port IP Address of Router 00 at the Host Site
 - At the *Local IP address*, enter the BRI port IP Address of the router at the DRM site

For example, **10.10.8.26**

1. Trademark of DYMEC, Inc.

- At *Local Mask address*, enter the BRI Port SubNet of the router at the DRM site

For example, **255.255.255.252**

5. Press the left arrow twice.
Response: The cursor is positioned at process selections (Y/N).
6. Enter y.
7. Press the esc key until the main menu is displayed.
Response: The main menu is displayed.

3.10.3.2 Configure the D-channel

1. Enter 3 for configuration.
Response: The Configuration Commands menu is displayed.
2. Enter 2 for port.
Response: The Configure Port menu is displayed.
3. Enter 300 for BRI.
Response: The ISDN Port Configuration menu is displayed.
4. Enter 1 to configure PRI/BRI D Channels.
Response: The ISDN D Channel menu is displayed.
5. At *Port Name*, enter BRI.
6. Press the left arrow.
Response: The cursor is positioned at process selections (Y/N).
7. Enter y.
8. Press the esc key until the main menu is displayed.
Response: The main menu is displayed.

3.10.3.3 Configure ISDN Incoming Telephone Numbers

1. Enter 3 for configuration.
Response: The Configuration Commands menu is displayed.
2. Enter 2 for port.
Response: The Configure Port menu is displayed.
3. Enter 300 for BRI.
Response: The ISDN Port Configuration menu is displayed.
4. Enter 2 to configure incoming telephone numbers.
Response: The ISDN Incoming Telephone Number and SPID menu is displayed.

5. Enter the following information in slot 1: (Use the arrow keys to navigate the screen.)
 - At *Telephone #*, enter circuit-switched data telephone number of the BRI
 - At *SPID*, enter the service Profile ID for the BRI
6. Press the left arrow.

Response: The cursor is positioned at process selections (Y/N).
7. Enter y.
8. Press the esc key until the main menu is displayed.

Response: The main menu is displayed.
9. Configure ISDN B Channel Port Configuration.

At the main menu, enter 3.
10. Enter 3 for configuration.

Response: The Configuration Commands menu is displayed.
11. Enter 2 for port.

Response: The Configure Port menu is displayed.
12. Enter 300 for BRI.

Response: The ISDN Port Configuration menu is displayed.
13. Enter 3 for B Channel Ports.

Response: The IP Port Information menu is displayed.
14. Enter the following information for Port 301 and Port 302: (Use the arrow keys to navigate the screen.)
 - At *Use*, enter IN/OUT. (Use the return key to change.)
 - At *Inbound Tel #*, enter the 10 digit telephone # for the BRI
 - At *Protocol*, enter PPP.
 - At *Class*, enter NONE.
 - At *ML*, enter N.
15. Press the left arrow.

Response: The cursor is positioned at process selections (Y/N).
16. Enter y.
17. Press the esc key until the main menu is displayed.

Response: The main menu is displayed.

3.10.3.4 Configure PRI Board Addresses/Masks/Protocols

1. Enter 3 for configuration.

Response: The Configuration Commands menu is displayed.

2. Enter 3 for router.
Response: The Router Commands menu is displayed.
3. Enter 5 for IP Port Information.
Response: The IP Port Information menu is displayed.
4. At the IP Port Information menu, enter the following information for the BRI port: (Use the arrow keys to navigate the screen.)
 - At *IP Address*, enter the BRI IP Address.
For example, **10.10.8.26**
 - At *IP mask*, enter the BRI port IP mask
 - At *Protocol*, enter RIP II. (Use the return key to change.)
5. Press the left arrow.
Response: The cursor is positioned at process selections (Y/N).
6. Enter *y*.

3.10.3.5 Add the BRI as a T1 back up (T1 connection to host) to the TDM Channel (port 8)

1. Enter 3 for configuration.
Response: The Configuration Commands menu is displayed.
2. Enter 2 for port.
Response: The Configure Port menu is displayed.
3. Enter 8 for T1 to Host.
Response: The Frame Relay Port Configuration menu is displayed.
4. Enter the following information: (Use the arrow keys to navigate the screen.)
 - At *Circuit Backup*, enter *Y*. (Use return key to change.)
 - At *Backup when line Down*, enter 150.
 - At *Restore when line Up*, enter 30.
 - At *Backup Location Name*, enter BRI to Host.
5. Press the left arrow.
Response: The cursor is positioned at process selections (Y/N).
6. Enter *y*.
7. Press the esc key until the main menu is displayed.
Response: The main menu is displayed.
8. Hold down the Ctrl key and press the w key.
Response: The settings are saved to flash.

3.10.4 Verify that BRI to PRI backup connection is established

1. Login to the Remote-Networking Router.
 1. Go to the call status page and watch the call status.
 2. At the Main Menu, enter 1.
 3. Enter 2.
2. Remove the T1 connection from port on the Remote-Networking Router. After 150 seconds the BRI to PRI backup connection is established. The call status page should indicate that it has been done.
3. Restore the T1 connection, the call status should be disconnected.

3.11 DRM Network Element Software Download Procedure

Purpose

The DRM Network Element Software Download Procedure is used to download a new version of software to a Cajun P333T switch or DynaStar 500 router configured in a DRM network.

When To Use

This procedure is performed when Lucent Technologies, Inc. has issued an Informational Software Update advertising an update to the Cajun switch or DynaStar router software. When an update is advertised, a Cajun switch or DynaStar router software download package will be available on the Lucent Electronic Delivery (LED) system.

A PDF file describing the Lucent Electronic Delivery directory structure at a high generic release level is published to the Customer Support/Download Section of *www.lucent.com*. This file entitled *Dir_Structure.pdf* provides navigational direction to upload/download software to/from the Lucent Electronic Delivery network.

The naming conventions for DRM software delivery products on Lucent Electronic Delivery are in the following format: *DRMyy-xxxx.zip*.

Where: yy = a two-digit year
 xxxx = a four-digit sequence number
 zip = a zip(compressed) file

When a DynaStar router software package is available, the software will need to be downloaded to all the routers in the DRM network. The DynaStar Router Software Download Procedure contained within the software package must be executed in its entirety for each router in the network.

Before You Begin

An understanding of the DRM network using the Lucent Technologies Network Component Solution (LNCS) is required. See, Section 2.7, The DRM Network for more information.

Caution: Executing the Cajun switch or DynaStar router software download procedure will result in loss of communication between the ASM (host) and one or more DRMs (remote) as follows:

- After software is downloaded to the Cajun switch, a reset is performed to restart the switch to run the new software. During the reset, communication is lost between the ASM and all DRMs for approximately 1 minute.
- After software is downloaded to a host DynaStar router, a reset is performed to restart the router to run the new software. During the reset, communication is lost between the ASM and up to 5 DRMs accessed by the host router for approximately 5 minutes. The following table shows the host router to DRM mapping:

Table 3.11-1 — Host Router To DRM Mapping Table

Host DynaStar Router 00 (host_a)	DRM1 – DRM5
Host DynaStar Router 01 (host_b)	DRM6 – DRM10
Host DynaStar Router 02 (host_c)	DRM11 – DRM 15

- After software is downloaded to the remote DynaStar router, a reset is performed to restart the router to run the new software. During the reset, communication is lost between the ASM and the single DRM accessed by the remote router for approximately 5 minutes.

Once communication is lost between the ASM and DRM(s), ASM services will begin to fail resulting in multiple error messages on the ROP. The ASM GUI and DRM 124 display page will also show the status for the ASM services as degraded. It may take up to 30 minutes for the ASM to restore the services after the network connection has been restored.

Executing this procedure to download software and re-initialize a Cajun switch will take approximately 10 minutes.

Executing this procedure to download software and re-initialize a DynaStar router will take approximately 10 minutes, not including ASM or DRM backups.

Required Tools

Access to the ASM with **root** permission is required.

Required Conditions

Log onto the ASM with **root** permission. If an HA-ASM configuration is being used, perform this procedure from the “lead” ASM. For more information, see Section “Accessing the ASM,” in 235-200-145, OneLink Manager Administrative Services Module User’s Guide.

Required Information

Before beginning this procedure, obtain the passwords and the IP addresses for the ASM and Cajun switch or DynaStar routers that will be downloaded with new software. This information should be stored in the office records. The following table provides the Lucent defined default IP addresses, a column to record the customer defined IP addresses if used, and a column to record the network element software version number.

Table 3.11-2 — IP Addresses and Software Versions Table

DRM Network Element	Lucent IP Address	Customer IP Address	Version Number
Simple ASM or HA ASM 1	10.10.1.1		
HA ASM 2	10.10.1.2		
Host Cajun Switch	10.10.1.245		
Host DynaStar Router 00	10.10.1.254		
Remote DynaStar Router – DRM 1	10.10.9.254		
Remote DynaStar Router – DRM 2	10.10.10.254		
Remote DynaStar Router – DRM 3	10.10.11.254		
Remote DynaStar Router – DRM 4	10.10.12.254		
Remote DynaStar Router – DRM 5	10.10.13.254		
Host DynaStar Router 01	10.10.1.253		
Remote DynaStar Router – DRM 6	10.10.17.254		
Remote DynaStar Router – DRM 7	10.10.18.254		
Remote DynaStar Router – DRM 8	10.10.19.254		
Remote DynaStar Router – DRM 9	10.10.20.254		
Remote DynaStar Router – DRM 10	10.10.21.254		
Host DynaStar Router 02	10.10.1.252		
Remote DynaStar Router – DRM 11	10.10.25.254		
Remote DynaStar Router – DRM 12	10.10.26.254		
Remote DynaStar Router – DRM 13	10.10.27.254		
Remote DynaStar Router – DRM 14	10.10.28.254		
Remote DynaStar Router – DRM 15	10.10.29.254		

PROCEDURE

3.11.1 Transfer A DRM Network Element Software Package From The LED System To The ASM.

Caution: *If errors occur during this procedure, seek next level of technical support.*

1. At the ASM *UNIX*¹ shell prompt, type and enter:

```
cd /tftpboot
```

Response:

ASM *UNIX* shell prompt will display.

2. Create working directory for the software download package, type and enter:

```
/bin/mkdir drm
```

Response:

ASM *UNIX* shell prompt will display.

3. Type and enter:

```
/bin/chmod 777 drm
```

1. Registered trademark in the United States and other countries licensed exclusively through X/Open Company Limited

Response:

ASM *UNIX* shell prompt will display.

4. Type and enter:

cd drm

Response:

ASM *UNIX* shell prompt will display.

5. Connect to the Lucent Electronic Delivery system, type and enter:

/bin/ftp 206.242.19.65

Response:

Messages similar to:

Connected to 206.242.19.65

220 scansdmz

FTP server (operating system version info) ready.

Followed by a login prompt.

6. Enter the appropriate Lucent Electronic Delivery login/password to connect.

Response:

A successful login returns a message similar to:

230 User <login ID> logged in. Access restrictions apply.
ftp>

7. Type and enter:

binary

Response:

A message similar to:

200 Type set to I.
ftp>

8. Change directory to the location of the software download package on Lucent Electronic Delivery, type and enter:

cd /5ESS/5Eg.v/VCDXg.v/zip

Where: g.v = 5E generic and version numbers

Response:

A message similar to:

250 CWD command successful.
ftp>

9. Transfer the software download package to the ASM, type and enter:

get DRMyy-xxxx.zip

Where: DRM = update for a DRM network element
yy = the last 2 digits of the year
xxxx = sequence number

Response:

A message similar to:

226 Binary Transfer complete.

Followed by the number of "bytes" and "time" it took to get the file from Lucent Electronic Delivery.

ftp>

10. Type and enter:

quit

Response:

A message similar to:

221 Goodbye.

Followed by the ASM *UNIX* shell prompt.

3.11.2 Execute the Cajun Switch or DynaStar Router Software Download Procedure

1. Extract the DRM Network Element software image file(s) and download procedure from the zip file. Type and enter:

```
/app/asm/sbin/unzip -j DRMyy-xxxx.zip
```

Where: DRM = update for a DRM network element
 yy = the last 2 digits of the year
 xxxx = sequence number

Response:

A message similar to:

```
Archive:  DRMyy-xxxx.zip  
          inflating: HDR
```

·
·
·

Followed by the ASM *UNIX* shell prompt.

2. Display and execute the Cajun switch or DynaStar router software download procedure. Type and enter:

```
/bin/pg /tftpboot/drm/MSGs.proc{version number}
```

Where: version number = Cajun switch or DynaStar router software version identified by the Informational Software Update advertising an update.

Response:

The first page of the software download procedure is displayed. Select the [return] key to display the next page of the procedure.

Execute all steps documented in the Cajun switch or DynaStar router software download procedure.

If executing the DynaStar router software download procedure, repeat this step for each DynaStar router configured in the DRM network before continuing to the next step.

If executing the Cajun switch software download procedure, continue to the next step.

3. Type and enter:

```
cd /tftpboot
```

Response:

ASM *UNIX* shell prompt will display.

4. Remove directory structure and files created by this procedure. Type and enter:

```
/bin/rm -rf drm
```

Response:

ASM *UNIX* shell prompt will display.

5. Exit from the ASM *UNIX* shell. Type and enter:

```
exit
```

Response:

ASM login prompt will display.

6. **STOP. YOU HAVE COMPLETED THIS PROCEDURE.**

3.12 Cajun Switch Software Version Procedure

Purpose

The Cajun Switch Software Version Procedure is used to obtain the version number for the software running on a Cajun switch configured in a DRM network.

Before You Begin

An understanding of the DRM network using the Lucent Technologies Network Component Solution (LNCS) is required. See, Section 2.7, The DRM Network for more information.

Required Tools

Access to the ASM with **root** permission is required.

Required Conditions

Log onto the ASM with **root** permission. If an HA-ASM configuration is being used, perform this procedure from the “lead” or “standby” ASM. For more information, see Section “Accessing the ASM,” in 235-200-145, OneLink Manager Administrative Services Module User’s Guide.

Required Information

Before beginning this procedure, obtain the IP address for the Cajun switch. This information should be stored in the office records. The following table provides the Lucent defined default IP address, a column to record the customer defined IP address if used, and a column to record the Cajun switch software version number.

Table 3.12-1 — Host Cajun IP Adresse and Software Version Table

DRM Network Element	Lucent IP Address	Customer IP Address	Version Number
Host Cajun Switch	10.10.1.245		

PROCEDURE

1. Establish a telnet connection to the Cajun switch, type and enter:

telnet X

Where: X = the Cajun IP Address

Response:

The software version number will be displayed with the Cajun switch welcome message followed by a login prompt.

2. Exit from the Cajun switch login prompt, type and enter:

[Ctrl] +]

(the control key followed by the left square bracket pressed at the same time)

Response:

Telnet prompt will display.

3. Exit from the telnet session, type and enter:

quit

Response:

ASM *UNIX*¹ shell prompt will display.

4. **STOP. YOU HAVE COMPLETED THIS PROCEDURE.**

1. Registered trademark in the United States and other countries licensed exclusively through X/Open Company Limited

3.13 DynaStar Router Software Version Procedure

Purpose

The DynaStar Router Software Version Procedure is used to obtain the version number for the software running on a DynaStar router configured in a DRM network.

Before You Begin

An understanding of the DRM network using the Lucent Technologies Network Component Solution (LNCS) is required. See, Section 2.7, The DRM Network for more information.

Required Tools

Access to the ASM with **root** permission is required.

Required Conditions

Log onto the ASM with **root** permission. If an HA-ASM configuration is being used, perform this procedure from the “lead” or “standby” ASM. For more information, see Section “Accessing the ASM,” in 235-200-145, OneLink Manager Administrative Services Module User’s Guide.

Required Information

Before beginning this procedure, obtain the IP address for the DynaStar routers. This information should be stored in the office records. The following table provides the Lucent defined default IP addresses, a column to record the customer defined IP addresses if used, and a column to record the DynaStar routers software version numbers.

Table 3.13-1 — DynaStar Router IP Addresses and Software Versions Table

DRM Network Element	Lucent IP Address	Customer IP Address	Version Number
Host DynaStar Router 00	10.10.1.254		
Remote DynaStar Router – DRM 1	10.10.9.254		
Remote DynaStar Router – DRM 2	10.10.10.254		
Remote DynaStar Router – DRM 3	10.10.11.254		
Remote DynaStar Router – DRM 4	10.10.12.254		
Remote DynaStar Router – DRM 5	10.10.13.254		
Host DynaStar Router 01	10.10.1.253		
Remote DynaStar Router – DRM 6	10.10.17.254		
Remote DynaStar Router – DRM 7	10.10.18.254		
Remote DynaStar Router – DRM 8	10.10.19.254		
Remote DynaStar Router – DRM 9	10.10.20.254		
Remote DynaStar Router – DRM 10	10.10.21.254		
Host DynaStar Router 02	10.10.1.252		
Remote DynaStar Router – DRM 11	10.10.25.254		
Remote DynaStar Router – DRM 12	10.10.26.254		
Remote DynaStar Router – DRM 13	10.10.27.254		
Remote DynaStar Router – DRM 14	10.10.28.254		
Remote DynaStar Router – DRM 15	10.10.29.254		

PROCEDURE

1. Establish a telnet connection to the DynaStar router, type and enter:

telnet X

Where: X = the DynaStar IP Address

Response:

Enter service selection

2. Select the DynaStar router CONSOLE service, type and enter:

1

Response:

The software version number will be displayed on the DynaStar router supervisor page followed by a login password prompt.

3. Exit from the DynaStar router login password prompt, type the Escape key:

[Esc]

Response:

ASM *UNIX*¹ shell prompt will display.

4. **STOP. YOU HAVE COMPLETED THIS PROCEDURE.**

1. Registered trademark in the United States and other countries licensed exclusively through X/Open Company Limited

3.14 Replace the Cajun P333T Ethernet Switch

Purpose

This procedure is used to replace a defective Cajun P333T Ethernet Switch in the Lucent Network Component Solution (LNCS) configuration with a replacement Cajun P333T Ethernet Switch.

When to Use

This procedure is used to replace only a defective Cajun P333T Ethernet Switch. The replacement of any other Cajun switch model, an ethernet switch of another manufacturer, or a Cajun P333T Ethernet Switch configured outside the scope of the LNCS configuration is not supported by this procedure.

Before You Begin

Before replacing the defective Cajun switch, preliminary checks should be performed to ensure that the cause of failure has not resulted from loss of power to the unit or the failure of an Ethernet interface cable.

Required Tools

The following equipment is required to perform the procedure:

- PC with VT100 emulator software or a VT100 terminal configured as follows (see table 3.14-1):

Table 3.14-1 — VT100 Settings For Cajun Switch Replacement Procedure

Setting	Value
Terminal Emulation	VT100
COM Port	Com 1 (or some other serial connector)
Baud Rate	9600
Data Bits	8
Parity	None
Stop Bits	1
Flow Control	None

- A flat-head screwdriver.
- A Philips #1 screwdriver.
- For direct Console communications, connect the Cajun P330 to the Console Terminal using the supplied RJ-45 crossed cable and RJ-45 to DB-9 adapter.

Table 3.14-2 — RJ-45 Pin Assignment

Cajun P330 RJ-45 Pin	Name
1	For Future Use
2	TXD (P330 input)
3	RXD (P330 output)
4	CD
5	GND
6	DTR
7	RTS
8	CTS

- Access to an ASM *UNIX*¹ shell.

Required Information

References to IP Address and Subnet Mask assignments in this procedure are the default assignments for the LNCS configuration. Obtain the necessary information from the office records when customer defined addressing is used.

PROCEDURE

1. Remove power to the Cajun switch by opening the circuit breaker for the DC power cable. To open the circuit breaker, push the fuse in while turning it counter clockwise, and pull the fuse out. The fuse-alarm LED above the fuse will be lit, and the **PWR** LED on the front of the unit will no longer be lit.
2. Use the Philips screwdriver to remove the DC power cable connected to the rear of the Cajun switch. The DC power cable is connected to the rear of the Cajun switch at a terminal block (positive '+', negative '-', and ground).

Note: The ground wire should be disconnected last.

3. Remove and label the cables connected to the front of the Cajun switch:
 - *Ethernet*² interface cables to the ASM(s) and host DynaStar router(s).
 - Console connector cable (if connected).
4. Use the flat-head screwdriver to remove the mounting screws securing the Cajun switch to the frame. The mounting screws are accessed by snap opening the hinged ends of the front panel. Save the screws for mounting the replacement Cajun switch to the frame.
5. Remove the Cajun switch from the bracket attached to the frame by sliding the unit forward.
6. Slide the replacement Cajun switch onto the mounting bracket attached to the frame.
7. Secure the replacement Cajun switch to the frame using the mounting screws that were removed in Step 4. Do not overtighten the screws. Snap close the hinged ends of the front panel once the screws are in place.

1. Registered trademark in the United States and other countries licensed exclusively through X/Open Company Limited
2. Trademark of Xerox.

8. Connect the cables that were removed in Step 3 to the appropriate connector ports at the front of the replacement Cajun switch.
9. Connect the DC power cable that was removed in Step 2 to the terminal block at the rear of the replacement Cajun switch.

Note: The ground wire should be connected first.

10. Power up the replacement Cajun switch by closing the circuit breaker for the DC power cable. To close the circuit breaker, insert the fuse that was removed in Step 1 by pushing in the fuse while turning it clockwise. The fuse-alarm LED above the fuse will no longer be lit, and the **PWR** LED on the front of the unit will be lit.
11. If not already connected in Step 8, connect a PC or VT100 terminal to the **Console** port at the front of the replacement Cajun switch. Refer to the **Required Tools** section in this procedure for additional information regarding the necessary cabling and terminal configuration.
12. Set-up the IP Address on the replacement Cajun switch as follows:

- a. Press the **Return / Enter** key (the name of this key is keyboard dependent) to display a login prompt.

Response:

The "Login:" prompt will be displayed.

If the expected response is not received, verify the appropriate cabling is being used (includes cable and connectors), the cable connection is secure at each end, and the terminal configuration is set-up correctly.

- b. Type and enter the "Supervisor Level" login name:

```
root
```

Response:

The "Password:" prompt will be displayed.

- c. Type and enter the "Supervisor Level" password:

```
root
```

Response:

```
Password accepted.  
P330-1(super)#
```

- d. Type and enter the following to program the IP Address on the replacement Cajun switch:

```
set interface inband 1 10.10.1.245 255.255.255.0
```

Response:

```
Management VLAN number set to 1  
Interface inband IP address set.  
You must reset the device in order for the change to take effect.
```

- e. Type and enter the following to have the IP Address take effect:

```
reset
```

Response:

This command will force a switch-over to the master module
and disconnect your telnet session
*** Reset *** - do you want to continue (Y/N)?

- f. Type and enter the "yes" confirmation:
y
Response:
Connection closed by foreign host.
The "Login:" prompt will be displayed shortly after.
 - g. Type and enter the "Supervisor Level" login name:
root
Response:
The "Password:" prompt will be displayed.
 - h. Type and enter the "Supervisor Level" password:
root
Response:
Password accepted.
P330-1(super)#
 - i. Type and enter the following to verify the correct set-up of the IP Address:
show interface
Response:

Interface Name	VLAN	IP address	Netmask
inband	1	10.10.1.245	255.255.255.0
ppp disabled	1	0.0.0.0	0.0.0.0
 - j. Type and enter the following to log off:
exit
Response:
The "Login:" prompt will be displayed.
13. Verify connectivity between the ASM and Host Routers through the replacement Cajun switch as follows:
- a. From the ASM *UNIX* console, login to the ASM *UNIX* shell.
 - b. Type and enter the following to verify connectivity between the ASM and the replacement Cajun switch:
ping 10.10.1.245
Response:
10.10.1.245 is alive
 - c. Type and enter the following to verify connectivity between the ASM and all Host Routers that are configured on the network (see Table 3.14-3):

Table 3.14-3 — Verify Connectivity Between ASM and Host Router

Command	Response
ping 10.10.1.254 (for Host Router A)	10.10.1.254 is alive
ping 10.10.1.253 (for Host Router B)	10.10.1.253 is alive
ping 10.10.1.252 (for Host Router C)	10.10.1.252 is alive

14. Remove the connection from the Console port at the front of the replacement Cajun switch if a terminal connection is no longer desired.
15. **STOP. YOU HAVE COMPLETED THIS PROCEDURE.**

3.15 Replace A *DynaStar 500'* Host Router or Remote Router

Purpose

This procedure replaces a defective *DynaStar 500* Host Router or Remote Router in the Lucent Network Component Solution (LNCS) configuration with a replacement *DynaStar 500* Host Router or Remote Router.

When to Use

This procedure is used to replace a defective *DynaStar 500* Router with a replacement *DynaStar 500* Router. The use of any other *DynaStar* Router model, a Router of another manufacturer, or a *DynaStar 500* Router configured outside the scope of the LNCS configuration is not supported by this procedure.

Before You Begin

Before replacing the defective Router, preliminary checks should be performed to ensure that the failure of the Router was not caused by loss of power to the unit, power switch(s) inadvertently placed to the off position, or the failure of an Ethernet interface cable.

Required Tools

The following equipment is required to perform the procedure:

- A replacement Router.

If a Host Router is being replaced, the replacement Router must be a replacement Host Router of the same equipage as the defective Host Router.

If a Remote Router is being replaced, the replacement Router must be a replacement Remote Router of the same equipage as the defective Remote Router.

- Supervisor Console (PC with VT100 emulator software or a VT100 terminal) configured as follows (see table 3.15-1):

1. Trademark of DYMEC, Inc.

Table 3.15-1 — VT100 Settings For DynaStar Router Replacement Procedure

Setting	Value
Terminal Emulation	VT100
COM Port	Com 1 (or some other serial connector)
Baud Rate	9600
Data Bits	7
Parity	Even
Stop Bits	1
Flow Control	None

- A cable (for connection between the Router console port and the Supervisor Console) with an RJ-69 interface and the following pin assignments:

Table 3.15-2 — RJ-69 Pin Assignment

Pin Number	Pin Assignment
1	Not Used
2	Request To Send (RTS)
3	Data Set Ready (DSR) ^a
4	Transmitted Data (TxD)
5	Received Data (RxD)
6	Ground (GND)
7	Data Terminal Ready (DTR)
8	Data Carrier Detect (DCD)
9	Clear To Send (CTS)
10	Not Used
Note(s):	
a. When port configured as DTE: DSR input not used. When port configured as DCE: DSR is an output.	

- Appropriate adapter(s) (e.g. RJ-69 to DB-25) for the serial port on the Supervisor Console (if needed).
- Philips #1 screwdriver
- Philips #2 screwdriver
- Philips #3 screwdriver
- Flat-head screwdriver

Required Information

References to IP Address and Subnet Mask assignments in this procedure are the default assignments for the LNCS configuration. Obtain the necessary information from the office records when customer defined addressing is used.

PROCEDURE

1. Verify that the compressed configuration file for the Router has been backed up.
 If replacing the Host Router, the compressed configuration file is stored on the ASM as one of the following files depending on the Host Router that is being replaced (Host Router A, Host Router B, or Host Router C) (see table 3.15-3):

Table 3.15-3 — Compressed Configuration File Location For Host Router

File Location	Router
<code>/varapp/dynastar/host_a/cnfgload.cmp</code>	Host Router A
<code>/varapp/dynastar/host_b/cnfgload.cmp</code>	Host Router B
<code>/varapp/dynastar/host_c/cnfgload.cmp</code>	Host Router C

Access the configuration file for the Host Router from the ASM *UNIX*² console.

If replacing the Remote Router, the compressed configuration file is stored on the DRM as “`/dynastar/cnfgload.cmp`”. Access the configuration file for the Remote Router from the DRM *UNIX* console.

Caution: *If the compressed configuration file has not been backed up, do not continue with this procedure, and seek technical support.*

2. Locate the Modular Fuse Filter Unit (MFFU) occupying the top row of the frame in which the defective Router resides. The MFFU contains a number of fuse blocks. Each fuse block contains four fuses.
3. From the back of the defective Router, follow the cable from the main Power Supply (PS1) to its corresponding fuse block on the back of the MFFU, and note which fuse it is attached to.
4. From the front of the MFFU, locate the fuse block and the fuse to which the PS1 cable is connected. Open the circuit breaker for the DC power cable to PS1 by pushing in the PS1 fuse while turning it counter-clockwise, and pulling the fuse completely out of the fuse block.

Response:

The fuse-alarm LED above the PS1 fuse will light up. The **PS1** and **ALARM** LEDs on the front cover of the defective Router will flash. The **PS2** LED will remain lit.

5. From the back of the defective Router, follow the cable from the redundant Power Supply (PS2) to its corresponding fuse block on the back of the MFFU, and note which fuse it is attached to.
6. From the front of the MFFU, locate the fuse block and the fuse to which the PS2 cable is connected. Open the circuit breaker for the DC power cable to PS2 by pushing in the PS2 fuse while turning it counter-clockwise, and pulling the fuse completely out of the fuse block.

Response:

The fuse-alarm LED above the PS2 fuse will light up. All LEDs on the front cover of the defective Router will turn off.

7. Remove and label all cables connected to the back of the defective Router such as:
 - Power Supply cables (PS1 and PS2) – connects to the MFFU

2. Registered trademark in the United States and other countries licensed exclusively through X/Open Company Limited

Note 1: Each Power Supply cable is connected into a plate which is screwed into the back of the defective Router. Do not remove the screws or the plate. Pull the Power Supply cable connector straight out from the middle of the plate to disconnect it.

Note 2: The fuse-alarm LEDs above the PS1 and PS2 fuses will go out when the Power Supply cables are disconnected from the back of the defective Router.

- *Ethernet*³ interface cable in Port 0 – connects to the Cajun Ethernet Switch from the Host Router or connects to the DRM from the Remote Router.
 - Console cable in Port 6 – connects to the Supervisor Console
 - T1 interface cable in Port 8 – connects to the T1 Network
8. From the front of the defective Router, using a flat-head screwdriver, remove the mounting screws that secure each side of the defective Router to the frame. Save the screws for mounting the replacement Router to the frame.
 9. Remove the defective Router (with the mounting brackets still attached) from the frame by sliding the unit forward.
 10. Using a Philips #1 screwdriver, loosen the captive screw located on the front access cover (top and center) of the defective Router. Open the front access cover by lowering it.
 11. Using a Philips #3 screwdriver, remove the four screws from the front of the defective Router located near the sides (two screws on each side). These screws hold the mounting brackets to the front of the defective Router. Save the screws for mounting the brackets onto the replacement Router.
 12. Press the power switches on both Power Supply units (PS1 and PS2) inside the defective Router to the “off” position (0). This ensures that the defective Router is turned off in the event that it is re-installed for testing purposes.
 13. Close the front access cover of the defective Router by folding the cover up, and using a Philips #1 screwdriver to tighten the captive screw located on the front access cover (top and center).
 14. Using a Philips #2 screwdriver, remove the mounting brackets from each side of the defective Router. Save the screws and brackets for mounting onto the replacement Router.
 15. Using a Philips #2 screwdriver, install the mounting brackets that were removed from the defective Router in Step 14 onto each side of the replacement Router, making sure the two holes at the front of the mounting bracket match up with the two holes at the front of the replacement Router.
 16. Using a Philips #1 screwdriver, loosen the captive screw located on the front access cover (top and center) of the replacement Router. Open the front access cover by lowering it.
 17. Press the power switches on both Power Supply units (PS1 and PS2) inside the replacement Router to the “off” position (0). This ensures that the replacement Router is initially turned off during installation.

3. Trademark of Xerox.

18. Using a Philips #3 screwdriver, install the four screws that were removed from the defective Router in Step 11 onto the front of the replacement Router (two screws on each side) to secure the mounting brackets onto the front of the Router.
19. Close the front access cover of the replacement Router by folding the cover up, and using a Philips #1 screwdriver to tighten the captive screw located on the front access cover (top and center).
20. Slide the replacement Router into the frame.
21. Secure the replacement Router to the frame using a flat-head screwdriver and the mounting screws that were removed in Step 8.
22. Connect the cables that were removed from the back of the defective Router in Step 7 to the back of the replacement Router.
23. Close the circuit breakers for the DC power cables to PS1 and PS2 by inserting the PS1 and PS2 fuses into the fuse blocks from which they were removed in Steps 4 and 6, and pushing the fuses in while turning them clockwise.
24. Using a Philips #1 screwdriver, loosen the captive screw located on the front access cover (top and center) of the replacement Router. Open the front access cover by lowering it.
25. Press the power switches on both Power Supply units (PS1 and PS2) inside the replacement Router to the "on" position (1).

Response:

The PS1 and PS2 fans inside the replacement Router will begin to spin.

If one or both of the fans do not spin, make sure that the corresponding PS1/PS2 fuse has been properly installed (pushed in all the way and sufficiently turned clockwise). If the fan still does not spin, **seek technical support**.

26. Close the front access cover of the replacement Router by folding the cover up, and using a Philips #1 screwdriver to tighten the captive screw located on the front access cover (top and center).

While the replacement Router is powering up, the Router executes power-on self tests which output status messages onto the Supervisor Console (if one was re-connected), and cause the LEDs on the front of the Router to go through a series of changes. The initial color of the LEDs are yellow/orange, which turn to red, briefly flash to green, and then completely turn off. At the conclusion of the power-on self tests, the top row of LEDs light up on the replacement Router, and the DynaStar Supervisor page is displayed on the Supervisor Console (if one was re-connected).

27. If a Supervisor Console was not re-connected to Port 6 of the replacement Router in Step 22, connect a Supervisor Console to the replacement Router. See "Local Log on to the Networking Router," Procedure 3.1.
28. Restore the Router configuration settings from the backup compressed configuration file.

If the Host Router was replaced, see "Restore the Configuration Settings for the DynaStar 500 (Base/Growth) Router at the 5ESS Switch Host Site," Procedure 3.6.

If the Remote Router was replaced, see “Restore the Configuration Settings for the DynaStar 500 (Base/Growth) Router at the DRM Site,” Procedure 3.5.

29. Reset the date and time on the replacement Router.
 - a. If the Supervisor Console is not displaying the *DynaStar Supervisor* page, type and enter **9999** at the * prompt to display the *DynaStar Supervisor* page.
 - Response:
The *Supervisor Console Types* information appears.
 - b. Type and enter **secret** (or the password set for your office) at the *Enter Password:* prompt.
 - Response:
The *Main Menu* page is displayed.
 - c. Type and enter **2** (for VT100 or ANSI compatible) at the *Enter Console Type:* prompt.
 - Response:
The *Main Menu* page is displayed.
 - d. Type and enter **4** for *System functions* at the *Enter command number:* prompt.
 - Response:
The *System Commands* menu is displayed.
 - e. Type and enter **1** for *Date & Time* at the *Enter command number:* prompt.
 - Response:
The *Change System Date & Time* menu is displayed.
 - f. Type and enter the current date and time, pressing the <enter> key after specifying each entry.

Example input for July 26, 2004; 1:08:00pm:

Current Date month: **7** (1-12)
day: **26** (1-31)
year: **4** (95-53)
Current Time hour: **13** (0-23)
minute: **8** (0-59)
second: **0** (0-59)

 - Response:
The cursor is positioned at the *Process new date and time (Y/N):* prompt.
 - g. Type and enter **Y** at the *Process new date and time (Y/N):* prompt.
 - Response:
The *System Commands* menu is displayed.
 - h. Press the <ESC> key to return to the *Main Menu* page.
 - i. Press the <ESC> key again to exit the *Main Menu* and display the *DynaStar Supervisor* page.

30. Verify connectivity between the ASM and the DRM through the replacement Router by executing the following:

If a Host Router was replaced go to step 31.

If a Remote Router was replaced go to step 32.

31. If a Host Router was replaced:

- a. From the ASM *UNIX* console, login to the ASM *UNIX* shell.
- b. Use the ping command to verify connectivity between the ASM and the replacement Host Router.

The format of the ping command is:

```
ping <IP address of replacement Host Router>
```

The value for the IP address of the replacement Host Router depends on the Host Router that was replaced. Type and enter one of the following commands that corresponds to the replacement Host Router (see Table 3.15-4):

Table 3.15-4 — Verify Connectivity Between ASM and Host Router

Command	Response
ping 10.10.1.254 (for Host Router A)	10.10.1.254 is alive
ping 10.10.1.253 (for Host Router B)	10.10.1.253 is alive
ping 10.10.1.252 (for Host Router C)	10.10.1.252 is alive

- c. Verify the connectivity between the ASM and all Remote Routers that are configured under the replacement Host Router:

The format of the ping command is:

```
ping <IP address of Remote Router>
```

The value for the IP address of the Remote Router depends on the Remote Routers that are configured under the replacement Host Router. Type and enter all of the following commands that correspond to the Remote Routers that are configured under the replacement Host Router (see table 3.15-5).

Table 3.15-5 — Verify Connectivity Between ASM and Remote Router

Host Router Replaced	Remote Router	Command	Response
Host Router A	Remote Router 1	ping 10.10.8.6	10.10.8.6 is alive
Host Router A	Remote Router 2	ping 10.10.8.10	10.10.8.10 is alive
Host Router A	Remote Router 3	ping 10.10.8.14	10.10.8.14 is alive
Host Router A	Remote Router 4	ping 10.10.8.18	10.10.8.18 is alive
Host Router A	Remote Router 5	ping 10.10.8.22	10.10.8.22 is alive
Host Router B	Remote Router 6	ping 10.10.16.6	10.10.16.6 is alive
Host Router B	Remote Router 7	ping 10.10.16.10	10.10.16.10 is alive
Host Router B	Remote Router 8	ping 10.10.16.14	10.10.16.14 is alive
Host Router B	Remote Router 9	ping 10.10.16.18	10.10.16.18 is alive
Host Router B	Remote Router 10	ping 10.10.16.22	10.10.16.22 is alive
Host Router C	Remote Router 11	ping 10.10.24.6	10.10.24.6 is alive
Host Router C	Remote Router 12	ping 10.10.24.10	10.10.24.10 is alive
Host Router C	Remote Router 13	ping 10.10.24.14	10.10.24.14 is alive
Host Router C	Remote Router 14	ping 10.10.24.18	10.10.24.18 is alive
Host Router C	Remote Router 15	ping 10.10.24.22	10.10.24.22 is alive

- d. Verify the connectivity between the ASM and all DRMs that are configured under the replacement Host Router:

The format of the ping command is:

```
ping <IP address of DRM>
```

The value for the IP address of the DRM depends on the DRMs that are configured under the replacement Host Router. Type and enter all of the following commands that correspond to the DRMs that are configured under the replacement Host Router (see table 3.15-6).

Table 3.15-6 — Verify Connectivity Between ASM and DRM

Host Router Replaced	DRM	Command	Response
Host Router A	DRM 1	ping 10.10.9.1	10.10.9.1 is alive
Host Router A	DRM 2	ping 10.10.10.1	10.10.10.1 is alive
Host Router A	DRM 3	ping 10.10.11.1	10.10.11.1 is alive
Host Router A	DRM 4	ping 10.10.12.1	10.10.12.1 is alive
Host Router A	DRM 5	ping 10.10.13.1	10.10.13.1 is alive
Host Router B	DRM 6	ping 10.10.17.1	10.10.17.1 is alive
Host Router B	DRM 7	ping 10.10.18.1	10.10.18.1 is alive
Host Router B	DRM 8	ping 10.10.19.1	10.10.19.1 is alive
Host Router B	DRM 9	ping 10.10.20.1	10.10.20.1 is alive
Host Router B	DRM 10	ping 10.10.21.1	10.10.21.1 is alive
Host Router C	DRM 11	ping 10.10.25.1	10.10.25.1 is alive
Host Router C	DRM 12	ping 10.10.26.1	10.10.26.1 is alive
Host Router C	DRM 13	ping 10.10.27.1	10.10.27.1 is alive
Host Router C	DRM 14	ping 10.10.28.1	10.10.28.1 is alive
Host Router C	DRM 15	ping 10.10.29.1	10.10.29.1 is alive

- e. If a second ASM exists in an HA-ASM configuration, repeat Step 31 from the second ASM.
- f. Go to step 33.

If connectivity fails at any point between an ASM and a DRM, **seek technical support**.

32. If a Remote Router was replaced:

- a. From the DRM *UNIX* console of the DRM that is configured under the replacement Remote Router, login to the DRM *UNIX* shell.
- b. Use the ping command to verify connectivity between the replacement Remote Router and the DRM that is configured under the replacement Remote Router.

The format of the ping command is:

```
ping <IP address of Remote Router>
```

The value for the IP address of the replacement Remote Router depends on the Remote Router that was replaced. Type and enter one of the following commands that corresponds to the replacement Remote Router (see table 3.15-7):

Table 3.15-7 — Verify Connectivity Between DRM and Remote Router

Remote Router Replaced	Configured To DRM	Command	Response
Remote Router 1	DRM 1	ping 10.10.9.254	10.10.9.254 is alive
Remote Router 2	DRM 2	ping 10.10.10.254	10.10.10.254 is alive
Remote Router 3	DRM 3	ping 10.10.11.254	10.10.11.254 is alive
Remote Router 4	DRM 4	ping 10.10.12.254	10.10.12.254 is alive
Remote Router 5	DRM 5	ping 10.10.13.254	10.10.13.254 is alive
Remote Router 6	DRM 6	ping 10.10.17.254	10.10.17.254 is alive
Remote Router 7	DRM 7	ping 10.10.18.254	10.10.18.254 is alive
Remote Router 8	DRM 8	ping 10.10.19.254	10.10.19.254 is alive
Remote Router 9	DRM 9	ping 10.10.20.254	10.10.20.254 is alive
Remote Router 10	DRM 10	ping 10.10.21.254	10.10.21.254 is alive
Remote Router 11	DRM 11	ping 10.10.25.254	10.10.25.254 is alive
Remote Router 12	DRM 12	ping 10.10.26.254	10.10.26.254 is alive
Remote Router 13	DRM 13	ping 10.10.27.254	10.10.27.254 is alive
Remote Router 14	DRM 14	ping 10.10.28.254	10.10.28.254 is alive
Remote Router 15	DRM 15	ping 10.10.29.254	10.10.29.254 is alive

- c. Use the ping command to verify connectivity between the DRM that is configured under the replacement Remote Router and the corresponding Host Router.

The format of the ping command is:

```
ping <IP address of Host Router>
```

The value for the IP address of the Host Router depends on the Remote Router that was replaced. Type and enter one of the following commands that corresponds to the replacement Remote Router and its Host Router (see table 3.15-8):

Table 3.15-8 — Verify Connectivity Between DRM and Host Router

Remote Router Replaced	Host Router	Command	Response
Remote Router 1	Host Router A	ping 10.10.8.5	10.10.8.5 is alive
Remote Router 2	Host Router A	ping 10.10.8.9	10.10.8.9 is alive
Remote Router 3	Host Router A	ping 10.10.8.13	10.10.8.13 is alive
Remote Router 4	Host Router A	ping 10.10.8.17	10.10.8.17 is alive
Remote Router 5	Host Router A	ping 10.10.8.21	10.10.8.21 is alive
Remote Router 6	Host Router B	ping 10.10.16.5	10.10.16.5 is alive
Remote Router 7	Host Router B	ping 10.10.16.9	10.10.16.9 is alive
Remote Router 8	Host Router B	ping 10.10.16.13	10.10.16.13 is alive
Remote Router 9	Host Router B	ping 10.10.16.19	10.10.16.19 is alive
Remote Router 10	Host Router B	ping 10.10.16.21	10.10.16.21 is alive
Remote Router 11	Host Router C	ping 10.10.24.5	10.10.24.5 is alive
Remote Router 12	Host Router C	ping 10.10.24.9	10.10.24.9 is alive
Remote Router 13	Host Router C	ping 10.10.24.13	10.10.24.13 is alive
Remote Router 14	Host Router C	ping 10.10.24.19	10.10.24.19 is alive
Remote Router 15	Host Router C	ping 10.10.24.21	10.10.24.21 is alive

- d. Type and enter the following command to verify connectivity between the DRM configured under the replacement Remote Router and the ASM:
- ```
ping 10.10.1.1
```
- Where: 10.10.1.1 = the IP address of the ASM
- Response:  
10.10.1.1 is alive
- e. If a second ASM exists in an HA-ASM configuration, type and enter the following command to verify connectivity between the DRM configured under the replacement Remote Router and the second ASM:
- ```
ping 10.10.1.2
```
- Where: 10.10.1.2 = the IP address of the second ASM
- Response:
10.10.1.2 is alive
- If connectivity fails at any point between a DRM and an ASM, **seek technical support.**
33. If a connection to the Supervisor Console is no longer desired, power down the console, and remove the cable from Port 6 of the Router.
34. **STOP. YOU HAVE COMPLETED THIS PROCEDURE.**

Distinctive Remote Module (DRM)

CONTENTS		PAGE
4.	ADMINISTRATIVE WORKSTATION MAINTENANCE	4 - 1
4.1	Halt the Administrative Module (AM) Emulator	4.1-1
4.2	Halt the Administrative Workstation	4.2-1
4.3	Restore Administrative Workstation	4.3-1
4.4	Backup Administrative Workstation Operating System	4.4-1
4.5	Boot Administrative Workstation From Alternate Disk	4.5-1
4.5.1	Replace a Defective Disk (<i>Netra t 1120</i>)	4.5.1-1
4.5.2	Replace a Defective Secondary Disk (<i>Netra 20</i>)	4.5.2-1
4.5.3	Replace a Defective Primary Disk (<i>Netra 20</i>)	4.5.3-1
4.5.4	Replace a Defective Primary Disk (<i>Netra 240</i>)	4.5.4-1
4.5.5	Replace a Defective Secondary Disk (<i>Netra 240</i>)	4.5.5-1
4.5.6	Partition and Propagate the System to the Non-Active Disk	4.5.6-1
4.5.7	Format the Secondary Disk from a Boot CD-ROM (<i>Netra t 1120</i>)	4.5.7-1
4.5.8	Format the Primary or Secondary Disk from a Boot CD-ROM (<i>Netra 20</i> or <i>Netra 240</i>)	4.5.8-1
4.6	Replace System Unit (<i>Netra t 1120</i> or <i>Netra 20</i>)	4.6-1
4.7	Remove Power to Administrative Workstation (<i>Netra t 1120</i> and <i>Netra 20</i>)	4.7-1
4.8	Restore Power to Administrative Workstation (<i>Netra t 1120</i> and <i>Netra 20</i>)	4.8-1
4.9	Remove Power to Administrative Workstation Units (<i>Netra</i> <i>240</i>)	4.9-1
4.10	Restore Power to Administrative Workstation Units (<i>Netra</i> <i>240</i>)	4.10-1
4.11	Replace a DAT or CD-ROM/DVD Drive (<i>Netra t 1120</i>)	4 . 1 1 - 1
4.12	Replace a DAT or DVD Drive (<i>Netra TM 20</i>)	4.12-1

4.13	Replace System Unit (<i>Netra 240</i>).	4.13-1
4.14	Replace a DAT Tape Drive Unit (<i>Netra 240</i>).	4.14-1
4.15	Remove Power to DAT Tape Drive Unit (<i>Netra 240</i>).	4.15-1
4.16	Restore Power to DAT Tape Drive Unit (<i>Netra 240</i>).	4.16-1
4.17	Replace a DVD Drive (<i>Netra 240</i>).	4.17-1
4.18	Replace a Power Supply Unit (<i>Netra 240</i>).	4.18-1
4.19	Load Tape in DAT Tape Drive Unit.	4.19-1
4.20	Unload Tape from DAT Tape Drive Unit.	4.20-1
4.21	Emergency Tape Ejection (<i>Netra t 1120</i> , <i>Netra 20</i> and <i>Netra 240</i>).	4.21-1
4.22	Clean the DAT Tape Drive Unit Head.	4.22-1

LIST OF FIGURES

Figure 4.5.1-1	— Hard Disk Drive Location.	4.5.1-1
Figure 4.5.2-1	— Removal of the <i>Netra 20</i> Hard Drives.	4.5.2-3
Figure 4.5.3-1	— Removal of the <i>Netra 20</i> Hard Drives.	4.5.3-3
Figure 4.5.4-1	— <i>Netra 240</i> Front Panel.	4.5.4-4
Figure 4.5.4-2	— <i>Netra 240</i> Hard Drive LED Indicators.	4.5.4-4
Figure 4.5.4-3	— <i>Netra 240</i> Disk Drive Access.	4.5.4-5
Figure 4.5.5-1	— <i>Netra 240</i> Front Panel.	4.5.5-4
Figure 4.5.5-2	— <i>Netra 240</i> Hard Drive LED Indicators.	4.5.5-4
Figure 4.5.5-3	— <i>Netra 240</i> Disk Drive Access.	4.5.5-5
Figure 4.6-1	— Administrative Workstation Interface Configuration (<i>Netra t 1120</i>).	4.6-2
Figure 4.6-2	— Administrative Workstation Interface Configuration (<i>Netra 20</i>).	4.6-2
Figure 4.6-3	— Serial Asynchronous Interface (SAI) for <i>Netra t 1120</i> .	4.6-3
Figure 4.6-4	— Serial Asynchronous Interface (SAI) for <i>Netra 20</i> .	4.6-3
Figure 4.6-5	— Quad Fast <i>Ethernet</i> - <i>Netra t 1120</i> Interface Connections.	4.6-4

Figure 4.6-6 — Quad Fast <i>Ethernet</i> - <i>Netra</i> 20 Interface Connections.	4.6-4
Figure 4.6-7 — MCC Interface to Administrative Workstation - <i>Netra</i> t 1120.	4.6-5
Figure 4.6-8 — MCC Interface to Administrative Workstation - <i>Netra</i> 20.	4.6-6
Figure 4.6-9 — STLWS and ROP Interface - <i>Netra</i> 20	4.6-6
Figure 4.6-10 — STLWS and ROP Interface - <i>Netra</i> t 1120	4.6-7
Figure 4.6-11 — SCANS/AMA/SCCS/Optional OSS Interface - <i>Netra</i> t 1120	4.6-8
Figure 4.6-12 — SCANS/AMA/SCCS/Optional OSS Interface - <i>Netra</i> 20	4.6-8
Figure 4.6-13 — Hard Disk Drive Location	4.6-9
Figure 4.6-14 — Removal of the <i>Netra</i> 20 Hard Drives	4.6-10
Figure 4.7-1 — <i>Netra</i> t 1120 Power Panel	4.7-1
Figure 4.7-2 — <i>Netra</i> 20 Power Panel	4.7-2
Figure 4.7-3 — Administrative Workstation Interface Configuration (<i>Netra</i> t 1120)	4.7-3
Figure 4.7-4 — Administrative Workstation Interface Configuration (<i>Netra</i> 20).	4.7-3
Figure 4.8-1 — Administrative Workstation Interface Configuration (<i>Netra</i> t 1120)	4.8-1
Figure 4.8-2 — Administrative Workstation Interface Configuration (<i>Netra</i> 20).	4.8-2
Figure 4.8-3 — <i>Netra</i> t 1120 Power Panel	4.8-2
Figure 4.8-4 — <i>Netra</i> 20 Power Panel	4.8-3
Figure 4.11-1 — Removal of the <i>Netra</i> t 1120 Top Cover.	4 . 1 1 - 1
Figure 4.11-2 — Removal of the <i>Netra</i> t 1120 CDROM/DVD and DAT Drive	4 . 1 1 - 2
Figure 4.12-1 — Removal of <i>Netra</i> 20 Top Cover.	4.12-1
Figure 4.12-2 — Removal of <i>Netra</i> 20 DAT or DVD	4.12-2
Figure 4.13-1 — NETRA 240 Front Fingerholds	4.13-2
Figure 4.13-2 — NETRA 240 Disk Drive	4.13-3
Figure 4.14-1 — NETRA 240 DAT Rear Panel	4.14-1

Figure 4.14-2 — NETRA 240 DAT Front Panel 4.14-2

Figure 4.15-1 — NETRA 240 DAT Rear Panel 4.15-1

Figure 4.15-2 — NETRA 240 DAT DC Power Connections 4.15-2

Figure 4.16-1 — NETRA 240 DAT Rear Panel 4.16-1

Figure 4.16-2 — NETRA 240 DAT DC Power Connections 4.16-2

Figure 4.17-1 — NETRA 240 Front Fingerholds 4.17-1

Figure 4.17-2 — NETRA 240 Front Fingerholds 4.17-2

Figure 4.18-1 — *Netra* 240 Power Supply 4.18-2

LIST OF TABLES

Table 4-1 — Tape Format and Size Capacity 4 - 2

Table 4.5-1 — AW Disk Drive Device IDs. 4.5-1

4. ADMINISTRATIVE WORKSTATION MAINTENANCE

Overview

This chapter covers maintenance of the *Netra*¹ t 1120, *Netra* 20 and *Netra* 240 (Administrative Workstation) located at the DRM office. Although procedure steps involving software commands can be performed via the ASM (via an OA&M cut-through), someone must be present at the DRM office to perform any hardware portions. The Administrative Workstation (AW) requires very little corrective maintenance and no routine maintenance.

In the event of a complete workstation failure, the entire AW should be replaced. In the rare case of a duplex hard disk failure, both hard disks must be replaced. Once the new workstation is installed with the appropriate interface cable connections, the software must be reloaded from backup tapes (created and kept current after the initial installation) and the SunOS + emulator tape or CD-ROM (accompanied the initial switch installation).

The following tapes and CD-ROM were provided with the switch hardware and contain all the necessary software to operate the switch:

1. SUN OS + Emulator - contains the SUN OS software and the 3B21 emulator software resident on the AW (provided during switch installation).
2. TOP (Tape Operating Procedure) - contains the necessary tape loading software.
3. Switching Module Text - contains the switching module text data normally resident in the switching module.
4. AM Text - Contains the emulated Administrative Module (AM) text data. There may be 1 or 2 AM text tapes.
5. AM ODD/ECD - Contains the emulated AM Office Dependent Data (ODD) and the necessary Equipment Configuration Database (ECD).
6. Switching Module ODD - Contains the switching module ODD necessary for call processing.

Note: Tapes 2 through 6 provided for installation will **NOT** work for office recovery resulting from workstation replacement. These tapes must be made after initial installation and kept current using the backup procedures in 235-105-210, **5ESS**[®] *Switch Routine Operations and Maintenance Procedures*.

See "Perform Office Dead Start Recovery," Procedure 7.1, for loading the software from the tape to the AW.

Digital Audio Tape (DAT) Tape Drive Unit

The Digital Audio Tape (DAT) tape drive unit connected to or built into the AW provides permanent storage for switch data. The DAT tape drive unit uses a tape cassette that loads and unloads from the unit in a simple manner.

The DAT tape drive unit is designed to use 4mm data-grade DDS cartridge media. Look for the DDS label on the tape cartridge to be sure you are using data-grade tape and not audio-grade tape. The tape cartridge should be of the same temperature as the drive for 24 hours prior to use. Table 4-1 lists the format and supported tape sizes and tape capacities in native (non-compressed) mode.

1. Trademark of Sun Microsystems, Inc.

Table 4-1 — Tape Format and Size Capacity

Format	Tape Size/Capacity
DDS-1 ^{ab}	60 meter/1.3 gbytes, 90 meter/2 gbytes
DDS-2 ^b	90 meter/2 gbytes, 120 meter/4 gbytes
DDS-3	90 meter/2 gbytes, 120 meter/4 gbytes, 125 meter/12 gbytes
DDS-4	90 meter/2 gbytes, 120 meter/4 gbytes, 125 meter/12 gbytes, 150 meter/20 gbytes
DAT72	125 meter/12 gbytes, 150 meter/20 gbytes , 170 meter/36 gbytes
Note(s):	
a. The <i>Netra</i> 20 DDS-4 DAT drive can read DDS-1 formatted tapes but cannot write DSS-1 formatted tapes.	
b. The <i>Netra</i> 240 DAT72 drive does not support DDS-1 or DDS-2 formatted tapes.	

When handling and storing tape cartridges, observe the following precautions:

- Keep cartridges away from anything magnetic.
- Store in a clean, dust-free environment, upright on edge rather than flat.
- Store in protective covers when not in use.
- Keep out of direct sunlight and away from extreme heat, cold or humidity.
- Cartridge must be at room temperature before using.
- Never open the tape access door on the cartridge and touch the magnetic recording surface.

To maintain reliability in the DAT tape drive unit, regular head cleaning is required. After every 25 hours of tape operation the unit should be cleaned using a DDS cleaning cartridge. See “Clean the DAT Tape Drive Unit Head,” Procedure 4.22.

4.1 Halt the Administrative Module (AM) Emulator

OVERVIEW

Before performing a number of critical maintenance tasks on the AW, ensure that the emulator has been properly halted. This shutdown operation of the emulator ensures that all processes will correctly restart when the emulator is returned to service.

PROCEDURE

1. If the *UNIX*¹ console is displayed, switch to the MCC page of the AW by holding down the Ctrl key and pressing **Enter** (not Return).
2. Ensure there is no Recent Change/Verify (RC/V) activity in progress.
3. Ensure there is no SCANS session in progress.
4. Ensure there is no Automatic Message Accounting (AMA) teleprocessing or tape writing sessions in progress.
5. Write the AMA data from memory to disk.

- (a) Enter the following input command:

WRT:AMADATA

Response:

```
WRT AMA DATA HAS BEEN WRITTEN TO DISK  
READY TO TRANSFER DATA FROM DISK TO OUTPUT MEDIUM
```

6. Isolate the switching module from the AW.
 - (a) Go to the **Switching Module Inhibit and Recovery Control Page**. Type and enter command **1800**
 - (b) Set switching module manual isolation. Type and enter: **403**
Response: **ISOLATE? (Y/N)**
 - (c) Type and enter **y** to the confirmation.
Response: **SET ISOL SM=x COMPLETED**
Where: x = The switching module number.
 - (d) If the switching module cannot be isolated, **seek technical assistance**.
7. Enter poke **59** on the MCC EAI page to halt the AM emulator.
Response: **Terminate emulator (y/n)?**
8. Type and enter **y** to the confirmation.
9. **STOP. YOU HAVE COMPLETED THIS PROCEDURE.**

1. Registered trademark in the United States and other countries, licensed exclusively through X/Open Company, Limited

4.2 Halt the Administrative Workstation

OVERVIEW

Before performing any type of maintenance on the AW, ensure that the workstation has been properly halted. This shutdown operation for the software ensures that all processes will correctly restart when the workstation is returned to service.

PROCEDURE

1. Halt the AM emulator.

Note: These are the same procedures as outlined in “Halt the Administrative Module (AM) Emulator,” Procedure 4.1.

- (a) If the *UNIX*¹ console is displayed, switch to the MCC page of the AW by holding down the Ctrl key and pressing **Enter** (not Return).
- (b) Ensure there is no Recent Change/Verify (RC/V) activity in progress.
- (c) Ensure there is no SCANS session in progress.
- (d) Ensure there is no Automatic Message Accounting (AMA) teleprocessing or tape writing sessions in progress.
- (e) Write the AMA data from memory to disk.
 - a. Enter the following input command:

WRT:AMADATA

```
WRT AMA DATA HAS BEEN WRITTEN TO DISK
READY TO TRANSFER DATA FROM DISK TO OUTPUT MEDIUM
```

- (f) Isolate the switching module from the AW.
 - a. Go to the **Switching Module Inhibit and Recovery Control Page**. Type and enter command **1800**
 - b. Set switching module manual isolation. Type and enter: **403**
Response: **ISOLATE? (Y/N)**
 - c. Type and enter **y** to the confirmation.
Response: **SET ISOL SM=x COMPLETED**
Where: x = The switching module number.
 - d. If the switching module cannot be isolated, **seek technical assistance**.
 - (g) Enter poke **59** on the MCC EAI page to halt the AM emulator.
Response: **Terminate emulator (y/n)?**
 - (h) Type and enter **y** to the confirmation.
2. Switch to the *UNIX* console of the AW by holding down the Ctrl key and pressing **Enter** (not Return) on the **MCC**.
 3. If a login prompt does not appear, press **Return** repeatedly until one appears.
 4. At the login prompt, login as **awadmin**, for example:

1. Registered trademark in the United States and other countries, licensed exclusively through X/Open Company, Limited

attaws console login: **awadmin**

5. From the Administrative Workstation Main Menu, select "Halt the Workstation," Answer **yes** to the confirmation. If you select a task by mistake, answer **no** to the confirmation, and the main menu will return.

Response:

You have chosen to halt the workstation. If the emulator is running, it must be halted before continuing. Refer to the main menu item of Halt the Emulator.

Do you want to continue (yes/no) **yes**

6. Wait for one of the following prompts. When one of these prompts appears, the workstation has been successfully halted.

Program Terminated

Type help for more information

ok

7. **STOP. YOU HAVE COMPLETED THIS PROCEDURE.**

4.3 Restore Administrative Workstation

OVERVIEW

This procedure provides the steps to take when the AW locks up and fails to respond to input commands or pokes entered on the MCC terminal.

The following items could cause the AW to lock up:

- The MCC terminal is powered down
- A Reset/Break key or key sequence is inadvertently entered
- The cables between the MCC and the AW are detached.

This procedure contains steps to restore the AW to operation.

PROCEDURE

1. Verify the MCC terminal is powered on and is properly connected to the *Sun*¹ workstation.
2. If an MCC page is displayed, switch to the *UNIX*² console of the AW by holding down the Ctrl key and pressing **Enter** (not Return).
3. Press the RETURN key several times.
If the "ok" prompt appears, proceed to Step 4.
If a "console login:" appears, proceed to Step 9.
4. Type and enter **go** and press the RETURN key.
Note: May need to type **go** twice
5. If the "console login:" prompt then appears, switch back to the MCC by holding down the Ctrl key and pressing **Enter** (not Return).
6. If the response is "Program terminated," at the "ok" prompt, type and enter: **boot**
7. Wait for the boot sequence to complete then switch back to the MCC by holding down the Ctrl key and pressing **Enter** (not Return).
8. Does the MCC now accept input commands and pokes?
If **YES**, **STOP. YOU HAVE COMPLETED THIS PROCEDURE.**
If **NO**, continue.
9. At the login prompt, log in as **awadmin**, for example.
console login: awadmin
10. From the Administrative Workstation Main Menu, select "Boot the Workstation". Answer **yes** to the confirmation. If you select a task by mistake, answer **no** to the confirmation.
Response:
You have chose to boot the workstation. If the Emulator is running, it must be halted before continuing. Refer to the Main Menu ite of Halt the Emulator.

1. Registered trademark of Sun Microsystems, Inc.

2. Registered trademark in the United States and other countries, licensed exclusively through X/Open Company, Limited

Do you want to continue (yes/no) **yes**

11. Wait for the boot sequence to complete and then switch back to the MCC by holding down the Ctrl key and pressing **Enter** (not Return).
12. Does the MCC now accept input commands and pokes?

If **YES**, **STOP. YOU HAVE COMPLETED THIS PROCEDURE.**

If **NO**, contact the next level of technical support.

4.4 Backup Administrative Workstation Operating System

OVERVIEW

This procedure should be run following an update to the AW operating system or the 3B21 emulator. This procedure should be used whenever a software update is applied which has **TARGET=EMULATOR**.

PROCEDURE

1. If an MCC page is displayed, switch to the *UNIX*¹ console of the AW, by holding down the Ctrl key and pressing **Enter** (not Return) on the **MCC**.
2. If a login prompt does not appear, press **Return** repeatedly until one appears.
3. At the login prompt, login as **awadmin**, for example:
console login: **awadmin**
4. From the Administrative Workstation Main Menu, select "Backup the workstation Operating System/Emulator to disk." (If you select a task by mistake, answer **no** to the confirmation, and the main menu will return.)
5. From the Operating System/Emulator Backup to Secondary Disk Menu, select "Execute backup of the workstation Operating System/Emulator to disk." Answer **yes** to the confirmation.

Response:

You have chosen to backup the workstation Operating System/Emulator to disk.

Do you want to continue? (yes/no) **yes**

This task takes about 15 minutes

6. If the AW is a *Netra*² t 1120, answer **no** to the following response:

Response:

Do you want to set the secondary disk bootable? **no**

If the AW is a *Netra* 20 or *Netra* 240 and the AW is running on the primary disk, answer **yes** to the following response:

Response:

Do you want to set the secondary disk bootable? **yes**

When completed, you will be prompted to press [RETURN]. When the prompt appears press [RETURN] or [ENTER] on the alpha keyboard.

7. If you wish to view the output of this OS backup, select "View output from the most recent operating system/emulator backup to disk." While viewing the output, use the following keys:

1. Registered trademark in the United States and other countries, licensed exclusively through X/Open Company, Limited
2. Registered trademark of Sun Microsystems, Inc.

- space** see the next screen of output
- b** see the previous screen of output
- h** see a list of available keys
- q** quit viewing output

8. Select "Return to main menu."
9. If the Administrative Workstation Operating System is only being backed up to disk, proceed to step 10.

If the Administrative Workstation Operating System is to be backed up to tape, proceed with step 12.
10. From the main menu, select "Exit."
11. **STOP. YOU HAVE COMPLETED THIS PROCEDURE.**
12. Insert a 4mm tape that may be overwritten into the DAT tape drive unit using "Load Tape in DAT Tape Drive Unit," Procedure 4.19.
13. From the **main menu**, select "Backup the workstation operating system/emulator to Tape."
14. From the Operating System/Emulator backup to tape menu, select "Execute backup of the workstation Operating System/Emulator to tape." Answer **yes** to the confirmation. If you select a task by mistake, answer **no** to the confirmation.

Response:

You have chosen to backup the workstation Operating System/Emulator to tape. Please ensure that there is a 4mm tape cartridge in the Digital Audio Tape (DAT) drive.

Do you want to continue? (yes/no) **yes**

This task will take approximately 20 minutes. When it is completed, you will be prompted to press Return. When the prompt appears, press Return.

15. If you wish to view the output of this OS backup to tape, select "View output from the most recent operating system/emulator backup to tape." While viewing the output, use the following keys:

- space** see the next screen of output
- b** see the previous screen of output
- h** see a list of available keys
- q** quit viewing output

16. Select "Return to the main menu."
17. From the main menu, select "Exit."
18. Unload the 4mm tape from the DAT tape drive unit using the procedure "Unload Tape from DAT Tape Drive Unit," Procedure 4.20. Be sure to protect the tape from being accidentally overwritten by sliding the white write-protect tab to the write protection side.

19. Label the tape with the following information:

Date: _____

Generic: _____

BWM Level: _____

Tape Type: Emulator and Sun OS

Tape Seq Number: _____

Comments: _____

The workstation operating system/emulator has been successfully backed up.

20. **STOP. YOU HAVE COMPLETED THIS PROCEDURE.**

4.5 Boot Administrative Workstation From Alternate Disk

OVERVIEW

This procedure should be used to replace a defective disk drive on the AW. On the *Netra*¹ t 1120, *Netra* 20 and *Netra* 240 both the primary disk and the secondary disk are internal drives. It is assumed that the secondary disk has been kept in sync with the primary drive by performing a backup to it recently. Table 4.5-1 lists the device IDs for the AW disk drives.

Table 4.5-1 — AW Disk Drive Device IDs

Workstation	Disk Interface	Primary Disk ID	Secondary Disk ID
<i>Netra</i> t 1120	SCSI	0	1
<i>Netra</i> 20	Fiber Channel	0	1
<i>Netra</i> 240	SCSI	0	1

PROCEDURE

1. Replace a Defective Disk (see Subprocedure 4.5.1 for *Netra* t 1120).
2. Replace a Defective Secondary Disk (see Subprocedure 4.5.2 for the *Netra* 20).
3. Replace a Defective Primary Disk (see Subprocedure 4.5.3 for the *Netra* 20).
4. Replace a Defective Primary Disk (see Subprocedure 4.5.4 for the *Netra* 240).
5. Replace a Defective Secondary Disk (see Subprocedure 4.5.5 for the *Netra* 240).
6. Partition and Propagate the System to the Non-Active Disk (see Subprocedure 4.5.6).

1. Trademark of Sun Microsystems, Inc.

4.5.1 Replace a Defective Disk (Netra¹ t 1120)

OVERVIEW

This procedure is used to replace a defective disk drive in the Administrative Workstation (AW).

Note: If the primary disk drive is being replaced, this procedure assumes that the secondary disk drive contains a backup of the 3B Emulator and Solaris Operating System software. The secondary disk drive will replace the primary disk drive and the replacement disk drive will be installed as the secondary disk.

Caution: *Follow proper ESD grounding procedures when handling AW units. Wear an antistatic wrist strap. Handle disk drives by their sides and store ESD-sensitive components in antistatic containers.*

PROCEDURE

1. Remove power to the AW. See "Remove Power to Administrative Workstation (Netra t 1120 and Netra 20)", Procedure 4.7.
2. Open the front access cover by twisting the two locking rings counter clockwise to the open position and lowering the front cover.

Remove the front ESD plate (See Figure 4.5.1-1). With a No.1 Phillips-head screwdriver, remove the captive screws.

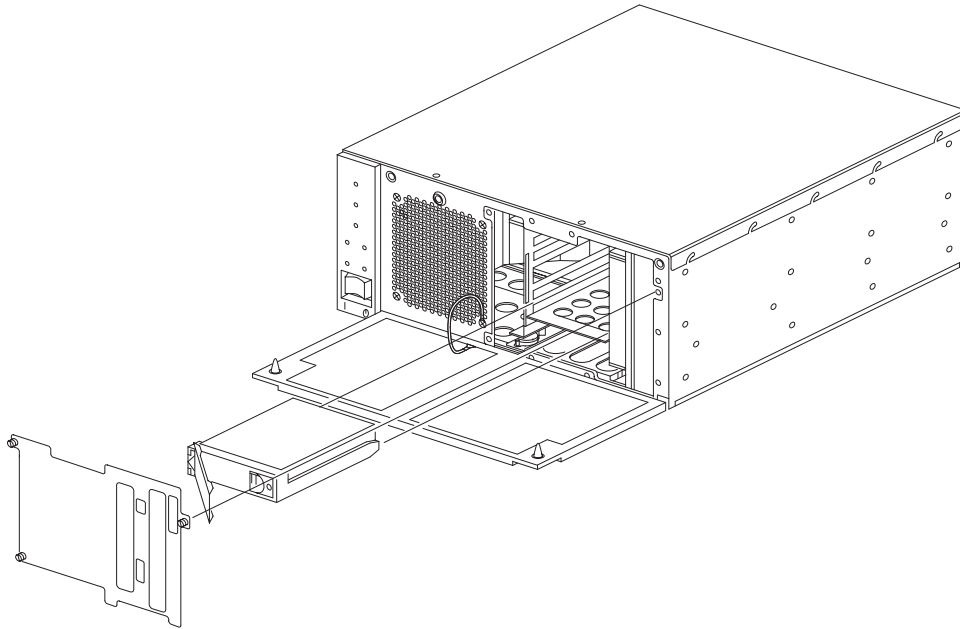

Figure 4.5.1-1 — Hard Disk Drive Location

3. Remove the secondary disk drive from the upper disk drive slot by pushing the latch to the right, extending the drive handle, and pulling the disk from the drive bay.
4. Is the primary disk drive being replaced?

1. Trademark of Sun Microsystems, Inc.

- If **YES**, continue with Step 5.
- If **NO**, skip to Step 7.
5. Remove the primary disk drive from the lower disk drive slot by pushing the latch to the right, extending the drive handle, and pulling the disk from the drive bay.
 6. Install the secondary disk drive removed in step 3 into the lower disk drive slot; pushing the disk into the drive bay until contact is made with the backplane connector. Push the drive handle to lock the drive into the system.
 7. Install the replacement disk drive in the upper disk drive slot; pushing the disk into the drive bay until contact is made with the backplane connector. Push the drive handle to lock the drive into the system.
 8. Replace the front ESD plate using a No.1 Phillips-head screwdriver to tighten the three retaining screws holding the ESD plate.
 9. Replace the front access cover by lifting into place against the AW chassis and twisting the two locking rings clockwise to the lock position.
 10. Restore power to the AW. See "Restore Power to Administrative Workstation (*Netra t 1120 and Netra 20*)", Procedure 4.8.
 11. Is the system booted and running the emulated AM environment?
If **YES**, proceed with Step 12.
If **NO**, **seek technical assistance.**
 12. Proceed to "Partition and Propagate the System to the Non-Active Disk," Subprocedure 4.5.6
 13. **STOP. YOU HAVE COMPLETED THIS PROCEDURE.**

4.5.2 Replace a Defective Secondary Disk (Netra¹ 20)

PROCEDURE

Note: This procedure requires a replacement disk to be available.

1. At the login prompt, login as root.
2. Execute the **mount** command and determine which Solaris disk the system is running on. If the output from the mount command shows the root partition as / on **/dev/dsk/c1t0d0s0**, the system is running on the primary disk. If the root partition is shown as / on **/dev/dsk/c1t1d0s0**, the system is running on the secondary disk.
3. Is the system running on the primary Solaris disk?
If **YES**, proceed with Step 6.
If **NO**, proceed with Step 4.
4. Is the AW stable enough to login?
If **YES**, stop the AW. See "Halt the Administrative Workstation", procedure 4.2.
If **NO**, and the system is not at the **ok** prompt, enter **~^B** (tilde control b).
5. Boot the system on the primary disk by entering **boot disk0** at the **ok** prompt.
6. If AM emulator is running, halt it following procedure 4.1, "Halt the Administrative Module (AM) Emulator".
7. At the login prompt, login as **awadmin**
8. From the Administrative Workstation Main Menu, select "Change Operating System booting disk". If given multiple disks to choose from, select task "1" to set the primary disk as the default boot disk:
Response:
1) Change the Workstation Default Boot Disk to Primary Disk
2) Change the Workstation Default Boot Disk to Secondary Disk
3) Return to the Main Menu
Select task by number (1-3): 1
If prompted to set the primary disk as the default boot disk, enter **yes**:
Response:
Do you want to change the default boot device to the primary disk (disk0)? **yes**
If prompted to set the secondary disk as the default boot disk, enter **no**:
Response:
Do you want to change the default boot device to the secondary disk (disk1)? **no**
9. When prompted, enter **return** to continue.
10. From the Administrative Workstation Main Menu, select "Exit"
11. At the login prompt, login as root.

1. Trademark of Sun Microsystems, Inc.

12. Enter the following command to set the system crash dump device to the primary disk.

```
dumpadm -d /dev/dsk/c1t0d0s1
```

13. Enter **luxadm remove_device /dev/rdisk/c1t1d0s2**. If the following response is received, enter “c” to continue. If this response is not received, **seek technical assistance**.

```
WARNING!!! Please ensure that no filesystems are mounted on these device(s).  
All data on these devices should have been backed up.
```

```
The list of devices which will be removed is:
```

```
1: Device name: /dev/rdisk/c1t1d0s2  
   Node WWN:    [unique WWN number for the disk unit]  
   Device Type:Disk device  
   Device Paths:  
   /dev/rdisk/c1t1d0s2
```

```
Please verify the above list of devices and  
then enter 'c' or <CR> to Continue or 'q' to Quit. [Default: c]
```

14. When prompted with the following response to remove the disk, continue with step 15. If this response is not received, **seek technical assistance**.

```
Response:
```

```
stopping: /dev/rdisk/c1t1d0s2....Done  
offlining: /dev/rdisk/c1t1d0s2....Done
```

```
Hit <Return> after removing the device(s).
```

15. Remove the front fascia from the workstation.
16. Locate the LED for the HDD (Hard Disk Drive) on the panel. Refer to Figure 4.5.2-1.

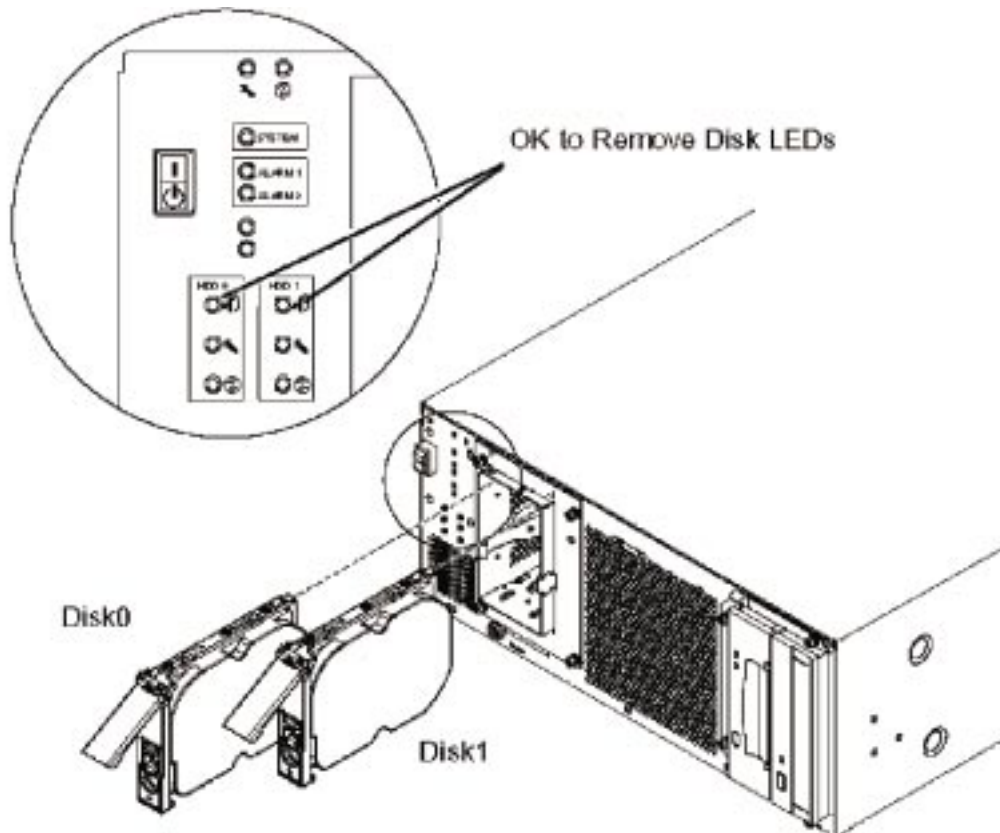

Figure 4.5.2-1 — Removal of the Netra 20 Hard Drives

17. Verify that the blue light indicating the disk can be removed is lit.
Note: If the Blue light does not light with 2 minutes after completing step 13, **seek technical assistance.**
18. Remove HDD1 (right disk).
 - a. Push the disk drive latch downwards to release the drive handle.
 - b. Extend the drive handle to disconnect the drive from the system.
 - c. Holding the drive handle, remove the drive from the drive bay.
19. Enter **return** at the console prompt. If the following response is not received, **seek technical assistance.**

```
Device: /dev/rdisk/ct1d0s2
Logical Nodes being removed under /dev/dsk/ and
/dev/rdisk:
ct1d0s0
ct1d0s1
ct1d0s2
ct1d0s3
ct1d0s4
ct1d0s5
ct1d0s6
ct1d0s7
```

20. Before installing the new secondary disk, enter **luxadm insert_device**. If the following response is received continue with step 21. If this response is not received, **seek technical assistance**.

Response:

```
Please hit (RETURN) when you have finished adding Fibre Channel  
Enclosure(s)/Device(s):
```

21. Install HDD1 (right disk)
- Holding the drive handle, push the drive into the drive bay until it makes contact with the Fibre Channel backplane connector.
 - Lock the drive in the bay by pressing on the drive handle until the drive latch closes.
22. Refit the front fascia on the workstation.
23. Enter **return** at the console prompt. If the following response is not received, **seek technical assistance**.

Response:

```
Waiting for Loop Initialization to complete...  
New Logical Nodes under /dev/dsk and /dev/rdisk :  
    clt1d0s0  
    clt1d0s1  
    clt1d0s2  
    clt1d0s3  
    clt1d0s4  
    clt1d0s5  
    clt1d0s6  
    clt1d0s7  
No new enclosure(s) were added!!
```

24. Log off (exit).
25. To partition and propagate the system to the non-active disk, follow steps in procedure "Partition and Propagate the System to the Non-Active Disk"4.5.6.
26. **STOP. YOU HAVE COMPLETED THIS PROCEDURE.**

4.5.3 Replace a Defective Primary Disk (Netra¹ 20)

PROCEDURE

Note: This procedure requires a replacement disk to be available.

1. At the login prompt, login as **root**.
2. Execute the **mount** command and determine which Solaris disk the system is running on. If the output from the mount command shows the root partition as / on **/dev/dsk/c1t0d0s0**, the system is running on the primary disk. If the root partition is shown as / on **/dev/dsk/c1t1d0s0**, the system is running on the secondary disk.
3. Is the system running on the secondary Solaris disk?
If **YES**, proceed with Step **6**.
If **NO**, proceed with Step **4**.
4. Is the AW stable enough to login?
If **YES**, stop the AW. See "Halt the Administrative Workstation", procedure 4.2.
If **NO**, and the system is not at the **ok** prompt, enter **~^B** (tilde control b).
5. Boot the system on the secondary disk by entering **boot disk1** at the **ok** prompt.
6. If AM emulator is running, halt it following procedure 4.1, "Halt the Administrative Module (AM) Emulator".
7. At the login prompt, login as **awadmin**
8. From the Administrative Workstation Main Menu, select "Change Operating System booting disk". If given multiple disks to choose from, select task "**2**" to set the secondary disk as the default boot disk:
Response:
1) Change the Workstation Default Boot Disk to Primary Disk
2) Change the Workstation Default Boot Disk to Secondary Disk
3) Return to the Main Menu
Select task by number (1-3): **2**
If prompted to set the primary disk as the default boot disk, enter **no**:
Response:
Do you want to change the default boot device to the primary disk (disk0)? **no**
If prompted to set the secondary disk as the default boot disk, enter **yes**:
Response:
Do you want to change the default boot device to the secondary disk (disk1)? **yes**
9. When prompted, enter **return** to continue.
10. From the Administrative Workstation Main Menu, select "Exit"
11. At the login prompt, login as **root**.

1. Trademark of Sun Microsystems, Inc.

12. Enter the following command to set the system crash dump device to the secondary disk.
dumpadm -d /dev/dsk/c1t1s0s1

13. Enter **luxadm remove_device /dev/rdisk/c1t0s0s2**. If the following response is received, enter “c” to continue. If this response is not received, **seek technical assistance**.

Response:

```
WARNING!!! Please ensure that no filesystems are mounted on these device(s).  
All data on these devices should have been backed up.
```

The list of devices which will be removed is:

```
1: Device name: /dev/rdisk/c1t0s0s2  
   Node WWN:    [unique WWN number for the disk unit]  
   Device Type:Disk device  
   Device Paths:  
     /dev/rdisk/c1t0s0s2
```

Please verify the above list of devices and then enter 'c' or <CR> to Continue or 'q' to Quit. [Default: c]

14. When prompted with the following response to remove the disk, continue with step 15. If this response is not received, **seek technical assistance**.

Response:

```
stopping: /dev/rdisk/c1t0s0s2....Done  
offlining: /dev/rdisk/c1t0s0s2....Done
```

Hit <Return> after removing the device(s).

15. Remove the front fascia from the workstation.
16. Locate the LED for the HDD (Hard Disk Drive) on the panel. Refer to Figure 4.5.3-1.

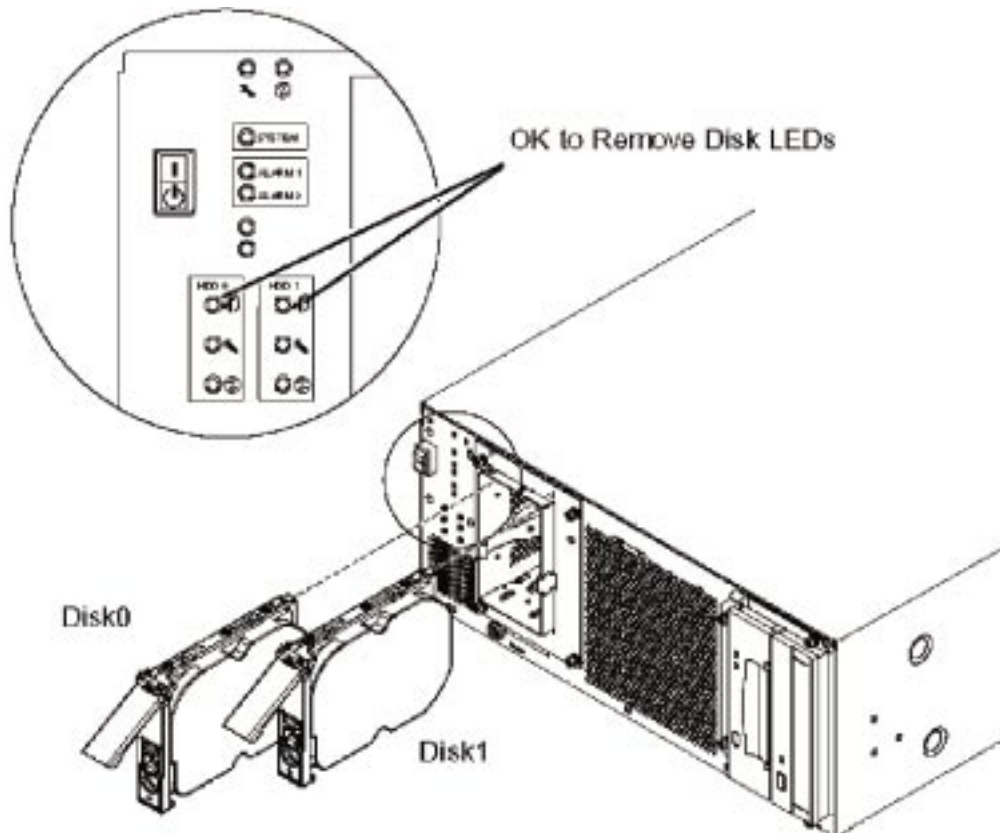

Figure 4.5.3-1 — Removal of the Netra 20 Hard Drives

17. Verify that the blue light indicating the disk can be removed is lit.
Note: If the Blue light does not light with 2 minutes after completing step 13, **seek technical assistance.**
18. Remove HDD0 (left disk).
 - a. Push the disk drive latch downwards to release the drive handle.
 - b. Extend the drive handle to disconnect the drive from the system.
 - c. Holding the drive handle, remove the drive from the drive bay.
19. Enter **return** at the console prompt. If the following response is not received, **seek technical assistance.**

```
Device: /dev/rdisk/c1t0d0s2
Logical Nodes being removed under /dev/dsk/ and
/dev/rdisk:
c1t0d0s0
c1t0d0s1
c1t0d0s2
c1t0d0s3
c1t0d0s4
c1t0d0s5
c1t0d0s6
c1t0d0s7
```

20. Before installing the new primary disk, enter **luxadm insert_device**. If the following response is received continue with step 21. If this response is not received, **seek technical assistance**.

Response:

```
Please hit (RETURN) when you have finished adding Fibre Channel  
Enclosure(s)/Device(s):
```

21. Install HDD0 (left disk)
- Holding the drive handle, push the drive into the drive bay until it makes contact with the Fibre Channel backplane connector.
 - Lock the drive in the bay by pressing on the drive handle until the drive latch closes.
22. Refit the front fascia on the workstation.
23. Enter **return** at the console prompt. If the following response is not received, **seek technical assistance**.

Response:

```
Waiting for Loop Initialization to complete...  
New Logical Nodes under /dev/dsk and /dev/rdisk :  
    clt0d0s0  
    clt0d0s1  
    clt0d0s2  
    clt0d0s3  
    clt0d0s4  
    clt0d0s5  
    clt0d0s6  
    clt0d0s7  
No new enclosure(s) were added!!
```

24. Log off (exit).
25. To partition and propagate the system to the non-active disk, follow steps in procedure "Partition and Propagate the System to the Non-Active Disk" 4.5.6.
26. At the login prompt, login as awadmin.
27. From the Administrative Workstation Main Menu, select "Change Operating System booting disk". If given multiple disks to choose from, select task "1" to set the secondary disk as the default boot disk:

Response:

- Change the Workstation Default Boot Disk to Primary Disk
- Change the Workstation Default Boot Disk to Secondary Disk
- Return to the Main Menu

Select task by number (1-3): 1

If prompted to set the primary disk as the default boot disk, enter **yes**:

Response:

```
Do you want to change the default boot device to the primary disk  
(disk0)? yes
```

If prompted to set the secondary disk as the default boot disk, enter **no**:

Response:

Do you want to change the default boot device to the secondary disk (disk1)? no

28. When prompted, enter **return** to continue.

29. From the Administrative Workstation Main Menu, select "Boot the Workstation". Answer **yes** to the confirmation. If you select a task by mistake, answer **no** to the confirmation.

You have chosen to boot the workstation. If the Emulator is running, it must be halted before continuing. Refer to the Main Menu item of Halt the Emulator.

Do you want to continue? (yes/no) yes

The AW will boot on the primary disk and automatically start the AM emulator.

30. Is the system booted and running the emulated AM environment?

If **YES**, proceed with Step 31.

If **NO**, seek technical assistance.

31. If a login prompt does not appear, press return repeatedly until one appears.

32. At the login prompt, login as root.

33. Enter the following command to set the system crash dump device to the primary disk.

```
dumpadm -d /dev/dsk/c1t0d0s1
```

34. Log off (exit).

35. **STOP. YOU HAVE COMPLETED THIS PROCEDURE.**

4.5.4 Replace a Defective Primary Disk (Netra¹ 240)

OVERVIEW

Note: This procedure requires a replacement disk drive to be available. Also, the secondary disk must be loaded with the appropriate 3B21 Emulator and Solaris² Operating System software for the office.

Caution: *Follow proper ESD grounding procedures when handling a disk drive unit. Wear an antistatic wrist strap. Handle the disk drive unit by the sides and store the disk drive unit in an antistatic container.*

PROCEDURE

1. Is the AW stable (that is, is Solaris running and are you able to log onto the system and execute UNIX³ commands)?

If **YES**, then go to Step 5.

If **NO**, then continue with the next Step.
2. Since the AW is not in a stable state, we will assume that the AW is either booted on the defective primary disk or operating in firmware mode (at the "ok" prompt).

If the system is at the **ok** prompt, then continue with the next Step.

If the MCC page of the AW is displayed, switch to the SUN⁴ console by holding down the [Ctrl] key and pressing the [Enter] key on the numeric keypad.

Enter a break sequence to get to firmware mode. The break sequences listed should be attempted in the order presented. Once in firmware mode, continue with the next Step. If you are unable to get to firmware mode, **seek technical assistance**.
 - i. Type a [~] (tilde), then hold down the [Ctrl] key and press [B].
 - ii. Hold down the [Ctrl] key and press Function key 5 [F5].
3. Boot the system on the secondary disk by entering

```
ok>boot disk1
```

Response:

The AW will boot on the secondary disk and automatically start the AM emulator.
4. Is the system booted and running the emulated AM environment?

If **YES**, then go to Step 13.

If **NO**, **seek technical assistance**.
5. If the MCC page of the AW is displayed, switch to the SUN console by holding down the [Ctrl] key and pressing the [Enter] key on the numeric keypad.

1. Registered trademark of Sun Microsystems, Inc.
2. Registered trademark of Sun Microsystems, Inc.
3. Trademark of X/Open Company Limited. UNIX is a registered trademark in the United States and other countries, licensed exclusively through X/Open Company Limited.
4. Registered trademark of Sun Microsystems, Inc.

6. Repeatedly press [RETURN] or [ENTER] on the alpha keypad until a login prompt or *UNIX* prompt appears.
If currently at a *UNIX* prompt, then proceed with Step 8. Otherwise, continue with the next Step.
7. At the login prompt, login as **root** . Obtain the root password for the AW from Lucent TSS if necessary.
8. Execute the `mount` command and determine which *Solaris* disk the system is running on.
If the output from the `mount` command shows the root partition as `/` on `/dev/dsk/c1t0d0s0`, the system is running on the primary disk.
If the root partition is shown as `/` on `/dev/dsk/c1t1d0s0`, the system is running on the secondary disk.
9. Is the system running on the secondary *Solaris* disk?
If **YES**, then proceed with Step 13.
If **NO**, then continue with the next Step.
10. Halt the system by following procedure 4.2 , "Halt the Administrative Workstation".
11. Boot the system on the secondary disk by entering
`ok>boot disk1`
Response:
The AW will boot on the secondary disk and automatically start the AM emulator.
12. Is the system booted and running the emulated AM environment?
If **YES**, then continue with the next Step.
If **NO**, **seek technical assistance**.
13. If the AM emulator is running, halt it by following procedure 4.1, "Halt the Administrative Module (AM) Emulator".
14. If the MCC page of the AW is displayed, switch to the *SUN* console by holding down the Ctrl key and pressing the Enter key on the numeric keypad.
15. Repeatedly press [RETURN] or [ENTER] on the alpha keypad until a login prompt or *UNIX* prompt appears.
If currently at a *UNIX* prompt, then log off using the **exit** command.
16. At the login prompt, login by typing
`awadmin`
17. From the Administrative Workstation Main Menu, select "Change Operating System booting disk". This Menu item will display one of three possible responses. Respond to the task or question as indicated.
 - If given multiple disks to choose from, select task "2" to set the secondary disk as the default boot disk.Response:

- 1) Change the Workstation Default Boot Disk to Primary Disk
- 2) Change the Workstation Default Boot Disk to Secondary Disk
- 3) Return to the Main Menu

Select task by number (1-3): 2

- If prompted to set the primary disk as the default boot disk, enter **no**.

Response:

```
Do you want to change the default boot device to the primary disk
(disk0)? no
```

- If prompted to set the secondary disk as the default boot disk, enter **yes**.

Response:

```
Do you want to change the default boot device to the secondary disk
(disk1)? yes
```

18. The previous Step prompts you to "Press **return** to continue...". If you have not done so already, enter [RETURN] or [ENTER] on the alpha keypad to continue.

19. From the Administrative Workstation Main Menu, select "**Exit**".

20. At the login prompt, login as **root**. Obtain the root password for the AW from Lucent TSS if necessary.

21. Enter the following command to set the system crash dump device to the secondary disk.

```
dumpadm -d /dev/dsk/c1t1d0s1
```

22. Enter the following command to determine the correct *Ap_Id* label for the primary disk drive.

```
cfgadm -al
```

Response:

Ap_Id	Type	Receptacle	Occupant	Condition
c0	scsi-bus	connected	configured	unknown
c0::dsk/c0t0d0	CD-ROM	connected	configured	unknown
c1	scsi-bus	connected	configured	unknown
c1::dsk/c1t0d0	disk	connected	configured	unknown
c1::dsk/c1t1d0	disk	connected	configured	unknown
c2	scsi-bus	connected	configured	unknown
c2::rmt/0	tape	connected	configured	unknown

23. Enter the following command to prepare the defective primary disk for removal.

```
cfgadm -c unconfigure c1::dsk/c1t0d0
```

24. Enter the following command to verify that the primary disk is unconfigured.

```
cfgadm -al
```

Response:

Ap_Id	Type	Receptacle	Occupant	Condition
c0	scsi-bus	connected	configured	unknown
c0::dsk/c0t0d0	CD-ROM	connected	configured	unknown
c1	scsi-bus	connected	configured	unknown

c1::dsk/c1t0d0	unavailable	connected	unconfigured	unknown
c1::dsk/c1t1d0	disk	connected	configured	unknown
c2	scsi-bus	connected	configured	unknown
c2::rmt/0	tape	connected	configured	unknown

25. Open the bezel at the front of the AW to access the primary disk drive. The bezel is opened by gripping the bezel at the two finger holds and rotating it down to its open position. See Figure 4.5.4-1 (*Netra 240 Front Panel*).

Netra 240 Front Panel

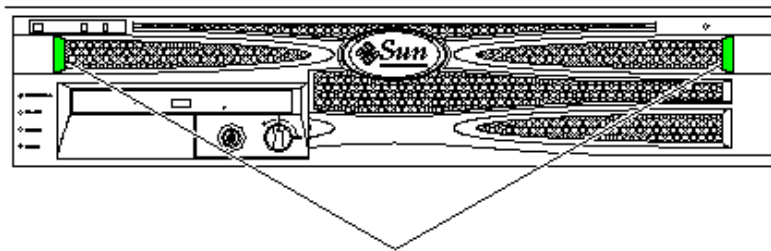

Green finger holds

Figure 4.5.4-1 — *Netra 240 Front Panel*

26. Locate the LED indicators for the primary disk (Hard Disk Drive 0 (HDD 0 - left disk)) on the panel. See Figure 4.5.4-2 (*Netra 240 Hard Drive LED Indicators*).

Netra 240 Hard Drive LED Indicators

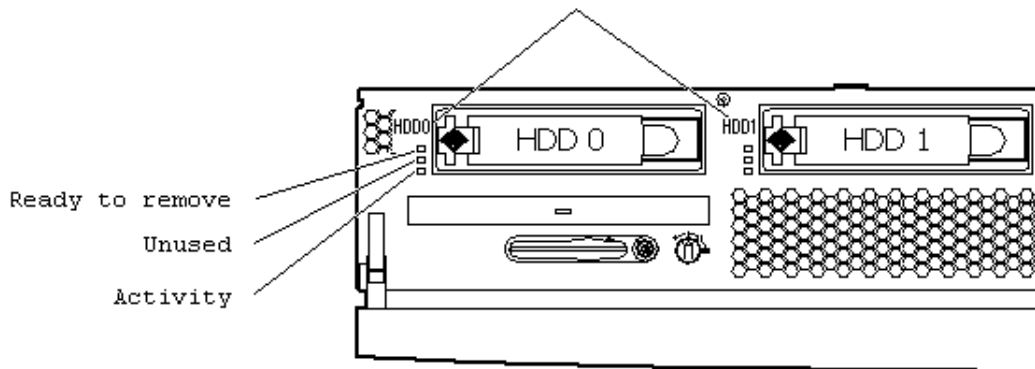

Figure 4.5.4-2 — *Netra 240 Hard Drive LED Indicators*

27. Verify that the "Ready to remove" indicator is ON (lit blue) indicating the primary disk can be removed.

Note: If the indicator is **not** ON (lit blue), **seek technical assistance**.

28. Remove the defective primary disk from the HDD 0 bay (left disk). See Figure 4.5.4-3 (*Netra 240 Disk Drive Access*).
 - a. Push the disk drive catch to the right to release the drive handle.
 - b. Extend the drive handle to disconnect the drive from the system.
 - c. Holding the drive handle, remove the drive from the drive bay.

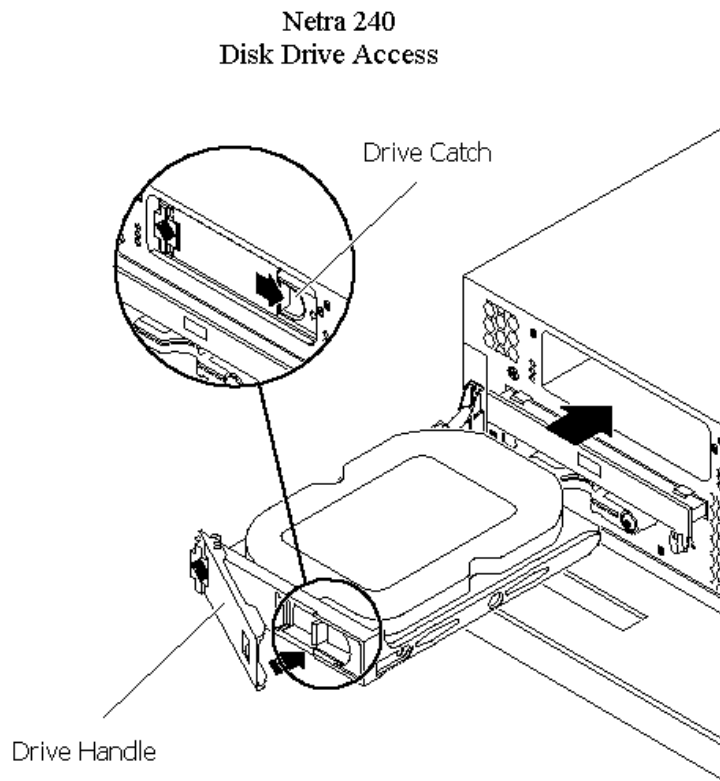

Figure 4.5.4-3 — Netra 240 Disk Drive Access

29. Install the replacement disk into the HDD 0 bay (left disk). See Figure 4.5.4-3 (*Netra 240 Disk Drive Access*).
 - a. Push the disk drive catch to the right to release the drive handle if necessary.
 - b. Holding the drive handle, push the drive into the drive bay until the metal lever starts to close. This indicates that the hard drive has engaged with its connector in the AW.

- c. Lock the drive in the bay by pressing on the drive handle until the drive catch closes.
30. Close the bezel at the front of the AW. The bezel is closed by gripping the bezel at the two finger holds and rotating it up to its closed position. See Figure 4.5.4-1 (*Netra 240 Front Panel*).
31. Enter the following command to logically connect the replacement disk to the operating system.

```
cfgadm -c configure c1::dsk/c1t0d0
```

Note: If an error occurs indicating a failure to configure the scsi device, verify that the replacement drive was properly inserted into the bay. Once the drive has been properly inserted into the bay, you will need to re-execute the `cfgadm` command using the `-f` option to force the configuration. If the error persists, **seek technical assistance**. Otherwise, continue with the next step.

32. Enter the following command to confirm that the replacement disk is now connected to the operating system.

```
cfgadm -al
```

Response:

Ap_Id	Type	Receptacle	Occupant	Condition
c0	scsi-bus	connected	configured	unknown
c0::dsk/c0t0d0	CD-ROM	connected	configured	unknown
c1	scsi-bus	connected	configured	unknown
c1::dsk/c1t0d0	disk	connected	configured	unknown
c1::dsk/c1t1d0	disk	connected	configured	unknown
c2	scsi-bus	connected	configured	unknown
c2::rmt/0	tape	connected	configured	unknown

33. Log off using the `exit` command.
34. To partition and propagate the system to the primary disk, follow procedure 4.5.6, "Partition and Propagate the System to the Non-Active Disk".
35. The previous Step booted the AW. If the MCC page of the AW is displayed, switch to the *SUN* console by holding down the [Ctrl] key and pressing the [Enter] key on the numeric keypad.
36. If a login prompt does not appear, repeatedly press [RETURN] or [ENTER] on the alpha keypad until one appears.
37. At the login prompt, login as **awadmin**.
38. From the Administrative Workstation Main Menu, select "Change Operating System booting disk". This Menu item will display one of three possible responses. Respond to the task or question as indicated.
 - If given multiple disks to choose from, select task "1" to set the primary disk as the default boot disk.

Response:

- 1) Change the Workstation Default Boot Disk to Primary Disk
- 2) Change the Workstation Default Boot Disk to Secondary Disk
- 3) Return to the Main Menu

Select task by number (1-3): 1

- If prompted to set the primary disk as the default boot disk, enter **yes**.

Response:

```
Do you want to change the default boot device to the primary disk
(disk0)?  yes
```

- If prompted to set the secondary disk as the default boot disk, enter **no**.

Response:

```
Do you want to change the default boot device to the secondary disk
(disk1)?  no
```

39. The previous Step prompts you to "Press **return** to continue...". If you have not done so already, enter [RETURN] or [ENTER] on the alpha keypad to continue.
40. From the Administrative Workstation Main Menu, select "Exit".
41. Halt the AM emulator by following procedure 4.1 , "Halt the Administrative Module (AM) Emulator".
42. If the MCC page of the AW is displayed, switch to the *SUN* console by holding down the [Ctrl] key and pressing the [Enter] key on the numeric keypad.
43. Repeatedly press [RETURN] or [ENTER] on the alpha keypad until a login prompt appears.
44. At the login prompt, login as **awadmin**.
45. From the Administrative Workstation Main Menu, select "Boot the Workstation". Answer **yes** to the confirmation. If you select a task by mistake, answer **no** to the confirmation.

Response:

```
You have chosen to boot the workstation.  If the Emulator is running,
it must be halted before continuing.  Refer to the Main Menu item of
Halt the Emulator
```

.

```
Do you want to continue? (yes/no) yes
```

The AW will boot on the primary disk and automatically start the AM emulator.

46. Is the system booted and running the emulated AM environment?
If **YES**, then continue with the next Step.
If **NO**, **seek technical assistance**.
47. If a login prompt does not appear, repeatedly press [RETURN] or [ENTER] on the alpha keypad until one appears.
48. At the login prompt, login as **root**. Obtain the root password for the AW from Lucent TSS if necessary.
49. Enter the following command to set the system crash dump device to the primary disk.

```
dumpadm -d /dev/dsk/c1t0d0s1
```

50. Log off using the exit command.
51. **STOP. YOU HAVE COMPLETED THIS PROCEDURE.**

4.5.5 Replace a Defective Secondary Disk (Netra¹ 240)

OVERVIEW

Note: This procedure requires a replacement disk drive to be available. Also, the primary disk must be loaded with the appropriate 3B21 Emulator and *Solaris*² Operating System software for the office.

Caution: *Follow proper ESD grounding procedures when handling a disk drive unit. Wear an antistatic wrist strap. Handle the disk drive unit by the sides and store the disk drive unit in an antistatic container.*

PROCEDURE

1. Is the AW stable (that is, is *Solaris* running and are you able to log onto the system and execute *UNIX*³ commands)?

If **YES**, then go to Step 5.

If **NO**, then continue with the next Step.
2. Since the AW is not in a stable state, we will assume that the AW is either booted on the defective secondary disk or operating in firmware mode (at the "**ok**" prompt).

If the system is at the **ok** prompt, then continue with the next Step.

If the MCC page of the AW is displayed, switch to the *SUN*⁴ console by holding down the [Ctrl] key and pressing the [Enter] key on the numeric keypad.

Enter a break sequence to get to firmware mode. The break sequences listed should be attempted in the order presented. Once in firmware mode, continue with the next Step. If you are unable to get to firmware mode, **seek technical assistance**.
 - i. Type a [~] (tilde), then hold down the [Ctrl] key and press [B].
 - ii. Hold down the [Ctrl] key and press Function key 5 [F5].
3. Boot the system on the primary disk by entering

```
ok>boot disk0
```

Response:

The AW will boot on the primary disk and automatically start the AM emulator.
4. Is the system booted and running the emulated AM environment?

If **YES**, then go to Step 13.

If **NO**, **seek technical assistance**.
5. If the MCC page of the AW is displayed, switch to the *SUN* console by holding down the [Ctrl] key and pressing the [Enter] key on the numeric keypad.

1. Registered trademark of Sun Microsystems, Inc.
2. Registered trademark of Sun Microsystems, Inc.
3. Trademark of X/Open Company Limited. UNIX is a registered trademark in the United States and other countries, licensed exclusively through X/Open Company Limited.
4. Registered trademark of Sun Microsystems, Inc.

6. Repeatedly press [RETURN] or [ENTER] on the alpha keypad until a login prompt or *UNIX* prompt appears.
If currently at a *UNIX* prompt, then proceed with Step 8. Otherwise, continue with the next Step.
7. At the login prompt, login as **root** . Obtain the root password for the AW from Lucent TSS if necessary.
8. Execute the `mount` command and determine which *Solaris* disk the system is running on.
If the output from the `mount` command shows the root partition as / on `/dev/dsk/c1t0d0s0`, the system is running on the primary disk.
If the root partition is shown as / on `/dev/dsk/c1t1d0s0`, the system is running on the secondary disk.
9. Is the system running on the primary *Solaris* disk?
If **YES**, then proceed with Step 13.
If **NO**, then continue with the next Step.
10. Halt the system by following procedure 4.2 , "Halt the Administrative Workstation".
11. Boot the system on the primary disk by entering
`ok>boot disk0`
Response:
The AW will boot on the primary disk and automatically start the AM emulator.
12. Is the system booted and running the emulated AM environment?
If **YES**, then continue with the next Step.
If **NO**, **seek technical assistance**.
13. If the AM emulator is running, halt it by following procedure 4.1, "Halt the Administrative Module (AM) Emulator".
14. If the MCC page of the AW is displayed, switch to the *SUN* console by holding down the Ctrl key and pressing the Enter key on the numeric keypad.
15. Repeatedly press [RETURN] or [ENTER] on the alpha keypad until a login prompt or *UNIX* prompt appears.
If currently at a *UNIX* prompt, then log off using the **exit** command.
16. At the login prompt, login by typing
`awadmin`
17. From the Administrative Workstation Main Menu, select "Change Operating System booting disk". This Menu item will display one of three possible responses. Respond to the task or question as indicated.
 - If given multiple disks to choose from, select task "1" to set the primary disk as the default boot disk.Response:

- 1) Change the Workstation Default Boot Disk to Primary Disk
- 2) Change the Workstation Default Boot Disk to Secondary Disk
- 3) Return to the Main Menu

Select task by number (1-3): 1

- If prompted to set the primary disk as the default boot disk, enter **yes**.

Response:

```
Do you want to change the default boot device to the primary disk
(disk0)? yes
```

- If prompted to set the secondary disk as the default boot disk, enter **no**.

Response:

```
Do you want to change the default boot device to the secondary disk
(disk1)? no
```

18. The previous Step prompts you to "Press **return** to continue...". If you have not done so already, enter [RETURN] or [ENTER] on the alpha keypad to continue.
19. From the Administrative Workstation Main Menu, select "**Exit**".
20. At the login prompt, login as **root**. Obtain the root password for the AW from Lucent TSS if necessary.
21. Enter the following command to set the system crash dump device to the primary disk.

```
dumpadm -d /dev/dsk/c1t0d0s1
```

22. Enter the following command to determine the correct *Ap_Id* label for the secondary disk drive.

```
cfgadm -al
```

Response:

Ap_Id	Type	Receptacle	Occupant	Condition
c0	scsi-bus	connected	configured	unknown
c0::dsk/c0t0d0	CD-ROM	connected	configured	unknown
c1	scsi-bus	connected	configured	unknown
c1::dsk/c1t0d0	disk	connected	configured	unknown
c1::dsk/c1t1d0	disk	connected	configured	unknown
c2	scsi-bus	connected	configured	unknown
c2::rmt/0	tape	connected	configured	unknown

23. Enter the following command to prepare the defective secondary disk for removal.

```
cfgadm -c unconfigure c1::dsk/c1t1d0
```

24. Enter the following command to verify that the secondary disk is unconfigured.

```
cfgadm -al
```

Response:

Ap_Id	Type	Receptacle	Occupant	Condition
c0	scsi-bus	connected	configured	unknown
c0::dsk/c0t0d0	CD-ROM	connected	configured	unknown

c1	scsi-bus	connected	configured	unknown
c1::dsk/c1t0d0	disk	connected	configured	unknown
c1::dsk/c1t1d0	unavailable	connected	unconfigured	unknown
c2	scsi-bus	connected	configured	unknown
c2::rmt/0	tape	connected	configured	unknown

25. Open the bezel at the front of the AW to access the secondary disk drive. The bezel is opened by gripping the bezel at the two finger holds and rotating it down to its open position. See Figure 4.5.5-1 (*Netra 240 Front Panel*).

Netra 240 Front Panel

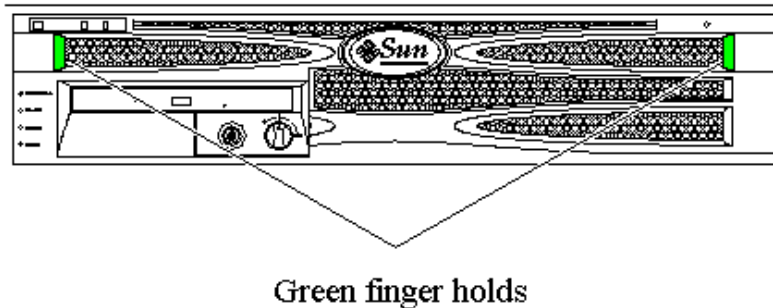

Figure 4.5.5-1 — Netra 240 Front Panel

26. Locate the LED indicators for the secondary disk (Hard Disk Drive 1(HDD 1- left disk)) on the panel. See Figure 4.5.5-2 (*Netra 240 Hard Drive LED Indicators*).

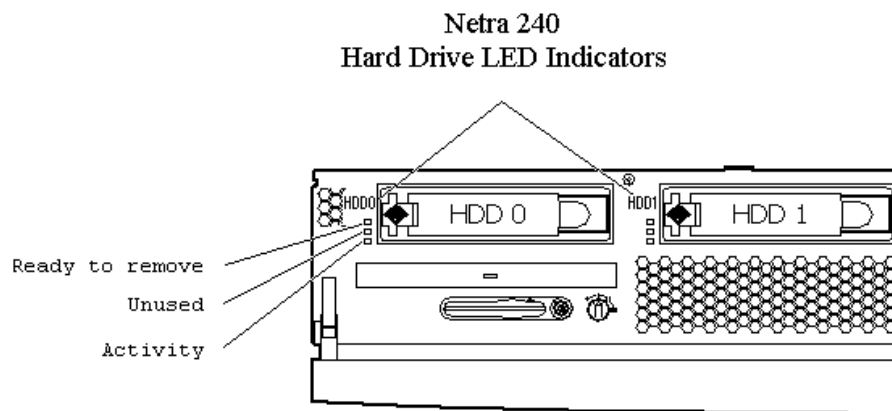

Figure 4.5.5-2 — Netra 240 Hard Drive LED Indicators

27. Verify that the "Ready to remove" indicator is ON (lit blue) indicating the secondary disk can be removed.

- Note:** If the indicator is **not** ON (lit blue), **seek technical assistance**.
28. Remove the defective secondary disk from the HDD 1bay (right disk). See Figure 4.5.5-3 (*Netra 240 Disk Drive Access*).
 - a. Push the disk drive catch to the right to release the drive handle.
 - b. Extend the drive handle to disconnect the drive from the system.
 - c. Holding the drive handle, remove the drive from the drive bay.

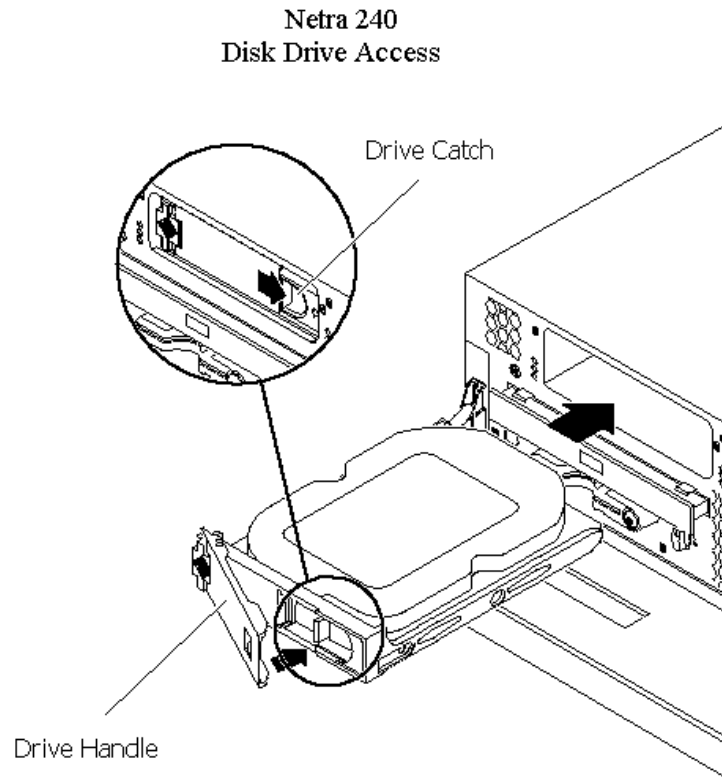

Figure 4.5.5-3 — Netra 240 Disk Drive Access

29. Install the replacement disk into the HDD 1bay (right disk). See Figure 4.5.5-3 (*Netra 240 Disk Drive Access*).
 - a. Push the disk drive catch to the right to release the drive handle if necessary.
 - b. Holding the drive handle, push the drive into the drive bay until the metal lever starts to close. This indicates that the hard drive has engaged with its connector in the AW.
 - c. Lock the drive in the bay by pressing on the drive handle until the drive catch closes.

30. Close the bezel at the front of the AW. The bezel is closed by gripping the bezel at the two finger holds and rotating it up to its closed position. See Figure 4.5.5-1 (*Netra 240 Front Panel*).

31. Enter the following command to logically connect the replacement disk to the operating system.

```
cfgadm -c configure c1::dsk/c1t1d0
```

Note: If an error occurs indicating a failure to configure the scsi device, verify that the replacement drive was properly inserted into the bay. Once the drive has been properly inserted into the bay, you will need to re-execute the `cfgadm` command using the `-f` option to force the configuration. If the error persists, **seek technical assistance**. Otherwise, continue with the next step.

32. Enter the following command to confirm that the replacement disk is now connected to the operating system.

```
cfgadm -al
```

Response:

Ap_Id	Type	Receptacle	Occupant	Condition
c0	scsi-bus	connected	configured	unknown
c0::dsk/c0t0d0	CD-ROM	connected	configured	unknown
c1	scsi-bus	connected	configured	unknown
c1::dsk/c1t0d0	disk	connected	configured	unknown
c1::dsk/c1t1d0	disk	connected	configured	unknown
c2	scsi-bus	connected	configured	unknown
c2::rmt/0	tape	connected	configured	unknown

33. Log off using the `exit` command.
34. To partition and propagate the system to the secondary disk, follow subprocedure 4.5.6, "Partition and Propagate the System to the Non-Active Disk".

Response:

The AW boots on the primary disk.

35. **STOP. YOU HAVE COMPLETED THIS PROCEDURE.**

4.5.6 Partition and Propagate the System to the Non-Active Disk

PROCEDURE

1. Halt the AM Emulator (see "Halt the Administrative Module (AM) Emulator," Procedure 4.1).
2. Switch to the *UNIX*¹ console of the AW by holding down the **Ctrl** key and pressing **Enter** (not Return).
3. If a login prompt does not appear, press **Return** repeatedly until a login prompt appears.
4. At the login prompt, login as **awadmin**:
console login: awadmin
5. From the Administrative Workstation Main Menu, select "Initialize a New Workstation Disk."
6. From the Disk Initialization menu, select "Execute initialization of a new workstation disk." Answer **yes** to the confirmation. If you select a task by mistake, answer **no** to the confirmation.

Response:

You have chosen to initialize a new workstation disk. If the emulator is running, it should be halted before continuing. Refer to the Main Menu item of Halt the Emulator

Do you want to continue? (yes/no) **yes**

7. This task will take approximately 15 minutes. When it is completed, you will be prompted to press Return. When the prompt appears, press **Return**.
8. If you wish to view the output of this disk initialization, select "View output from the most recent disk initialization." While viewing the output, use the following keys:

space see the next screen of output
b see the previous screen of output
h see a list of available keys
q quit viewing output

9. Select "Return to main menu."
10. If the "Execute initialization of a new workstation disk" task completed successfully, proceed to Step 17..
11. If the "Execute initialization of a new workstation disk" task failed, the new disk must first be formatted from a bootable tape or CD-ROM.

If the AW is a *Netra*² t 1120, follow "Format the Secondary Disk from a Boot CD-ROM (*Netra* t 1120), Procedure 4.5.7.

1. Registered trademark in the United States and other countries, licensed exclusively through X/Open Company, Limited
2. Trademark of Sun Microsystems, Inc.

If the AW is a *Netra 20* or *Netra 240*, follow "Format the Primary or Secondary Disk from a Boot CD-ROM (*Netra 20* or *Netra 240*), Procedure 4.5.8.

After the new disk is formatted, the AW will reboot and automatically start the AW emulator.

12. Is the system booted and running the emulated AM environment?

If **YES**, proceed with Step 13.

If **NO**, seek technical assistance.

13. Halt the emulator. See "Halt the Administrative Module (AM) Emulator", Procedure 4.1.
14. Switch to the AW by holding down the **Ctrl** key and pressing **Enter** (not Return).
15. If a login prompt does not appear, press **Return** repeatedly until one does.
16. At the login prompt, login as **awadmin**:
console login: awadmin
17. From the Administrative Workstation Main Menu, select "Backup the workstation Operating System/Emulator to disk." to execute. If you select a task by mistake, answer **no** to the confirmation, and the main menu will return.
18. From the Operating System/Emulator Backup To Secondary Disk Menu, select "Execute backup of the workstation Operating System/Emulator to disk". Answer **yes** to the following confirmation. If you select a task by mistake, answer **no** to the confirmation.

Response:

You have chosen to backup the workstation Operating System/Emulator to disk.

Do you want to continue? (yes/no) **yes**

19. If the AW is a *Netra t 1120*, answer **no** to the following response:

Response:

Do you want to set the secondary disk bootable? **no**

If the AW is a *Netra 20* or *Netra 240*, and the secondary disk is the non-active disk, answer **yes** to the following response:

Response:

Do you want to set the secondary disk bootable? **yes**

When completed, you will be prompted to press return. When the prompt appears, press **return**.

20. Select "Return to the main menu."
21. From the Administrative Workstation Main Menu, select "Boot the Workstation". Answer **yes** to the confirmation. If you select a task by mistake, answer **no** to the confirmation.

Response:

You have chosen to boot the workstation. If the Emulator is running, it must be halted before continuing. Refer to the Main Menu item of Halt the Emulator.

- Do you want to continue? (yes/no) yes
The AW will boot on the primary disk and automatically start the AM emulator
22. Is the system booted and running the emulated AM environment?
If **YES**, proceed with Step **23**.
If **NO**, seek technical assistance.
 23. Switch to the MCC by holding down the **Ctrl** key and pressing **Enter** (not Return).
Wait for page 111 to be redisplayed.
 24. Go to MCC page 111/112 and use the **30X** command to restore MHD 1 and 3 to service.
 25. **STOP. YOU HAVE COMPLETED THIS PROCEDURE.**

4.5.7 Format the Secondary Disk from a Boot CD-ROM (Netra¹ t 1120)

PROCEDURE

1. Stop the AW. See "Halt the Administrative Workstation," Procedure 4.2.
2. Load the 3B21 Emulator and Operating System CD-ROM into the CD-ROM drive.
3. Enter the following command at the **ok** prompt to boot the AW from the CD-ROM/DVD-ROM:

boot cdrom

If "cdrom" is not defined correctly, use the following commands to verify the CD-ROM drive SCSI ID and set the CD-ROM device alias:

devalias

nvalias cdrom /pci@1f,4000/scsi@3/disk@5,0:f

The AW starts to boot from the CD-ROM, messages similar to those shown in the following example are output on the system console:

```
Resetting ...  
screen not found.  
Can't open input device.  
Keyboard not present. Using ttya for input and output.
```

```
Sun Ultra 60 UPA/PCI (UltraSPARC-II 440 MHz), No keyboard  
OpenBoot 3.29, 512 MB memory installed, Serial #13079967  
Ethernet address 8:0:20:c7:95:9f, Host ID: 80c7959f.
```

```
Initializing Memory  
Rebooting with command: boot cdrom  
Boot device: /pci@1f,4000/scsi@3/disk@5,0:f File and args:  
SunOS Release 5.8 Version Generic-108528-13 64-bit  
Copyright 1983-2001 Sun Microsystems, Inc. All rights reserved
```

```
·  
·  
·
```

After the system boots on the CD-ROM, the 3B21 Emulator and Operating System CD-ROM Installation main menu is displayed.

4. From the main menu, select "Format and Load the Secondary Disk from CD-ROM" Answer **yes** to the confirmation. If you select a task by mistake, answer **no** to the confirmation.

Response:

You have chosen to format and load the secondary disk from CD-ROM.

WARNING:

If you continue, the secondary disk operating system partitions will be overwritten with data from the CD-ROM and its MHD partitions are preserved.

Do you want to continue? (yes/no) **yes**

This task will take approximately 30 minutes. Answer **no** if the following question is asked:

1. Trademark of Sun Microsystems, Inc.

(5e14.1 - 5e16.1 only):

Do you want to set the secondary disk bootable? **no**

(5e16.2 and later):

Do you want to change /etc/vfstab to make the secondary disk bootable? **no**

When it is completed, you will be prompted to press Return. When the prompt appears, press Return.

5. From the main menu, select "Exit and Boot the Workstation" (5e14.1 – 5e16.1) or "Boot the Workstation on the Default Boot Disk" (5e16.2 and later). Answer **yes** to the confirmation. If you select a task by mistake, answer **no** to the confirmation.

Response:

You have chosen to boot the workstation ...

Do you want to continue? (yes/no) **yes**

The AW will boot and automatically start the AM emulator..

6. Is the system booted and running the emulated AM environment ?
If **YES, STOP. YOU HAVE COMPLETED THIS PROCEDURE.**
If **NO, seek technical assistance.**

4.5.8 Format the Primary or Secondary Disk from a Boot CD-ROM (*Netra*¹ 20 or *Netra* 240)

PROCEDURE

1. Stop the AW. See “Halt the Administrative Workstation,” Procedure 4.2.
2. Load the 3B21 Emulator and Operating System CD-ROM into the CD-ROM/DVD drive.
3. Enter the following command at the **ok** prompt to boot the AW from the CD-ROM/DVD:

boot cdrom

If “cdrom” is not defined correctly, use the following commands to verify the CD-ROM/DVD drive device ID and set the CD-ROM device alias:

For a *Netra* 20:

devalias

nvalias cdrom /pci@8,700000/scsi@6/disk@6,0:f

For a *Netra* 240:

devalias

nvalias cdrom /pci@1e,600000/ide@d/cdrom@0,0:f

The AW starts to boot from the CD-ROM, messages similar to those shown in the following example are output on the system console:

For a *Netra* 20:

Resetting ...

```
Sun Netra T4 (UltraSPARC-III+), No keyboard
Copyright 1998-2002 Sun Microsystems, Inc. All rights reserved.
OpenBoot 4.5, 512 MB memory installed, Serial #51344136.
Ethernet address 0:3:ba:f:73:8, Host ID: 830f7308.
```

Initializing Memory

Rebooting with command: boot cdrom

Boot device: /pci@8,700000/scsi@6/disk@6,0:f File and args:

SunOS Release 5.8 Version Generic-108528-13 64-bit

Copyright 1983-2001 Sun Microsystems, Inc. All rights reserved.

·
·
·

For a *Netra* 240:

Resetting ...

Netra 240, No keyboard

Copyright 1998-2003 Sun Microsystems, Inc. All rights reserved.

OpenBoot 4.11.4, 1024 MB memory installed, Serial #59810525.

Ethernet address 0:3:ba:90:a2:dd, Host ID: 8390a2dd.

Initializing Memory

Rebooting with command: boot cdrom

Boot device: /pci@1e,600000/ide@d/cdrom@0,0:f File and args:

1. Trademark of Sun Microsystems, Inc.

SunOS Release 5.8 Version Generic-108528-29 64-bit
Copyright 1983-2003 Sun Microsystems, Inc. All rights reserved.

·
·
·

After the system boots on the CD-ROM, the 3B21 Emulator and Operating System CD-ROM Installation main menu is displayed.

4. Is this procedure being used to format the primary disk?

If **YES**, proceed with Step 5.

If **NO**, proceed with Step 6.

5. From the main menu, select "Format and Load the Primary Disk from CD-ROM". Answer **yes** to the confirmation. If you select a task by mistake, answer **no** to the confirmation.

Response:

You have chosen to format and load the primary disk from CD-ROM.

WARNING:

If you continue, the primary disk operating system partitions will be overwritten with data from the CD-ROM and its MHD partitions are preserved.

Do you want to continue? (yes/no) **yes**

This task will take approximately 30 minutes.

When it is completed, you will be prompted to press **Return**. When the prompt appears, press **Return** and continue with step 7.

6. From the main menu, select "Format and Load the Secondary Disk from CD-ROM". Answer **yes** to the confirmation. If you select a task by mistake, answer **no** to the confirmation.

Response:

You have chosen to format and load the secondary disk from CD-ROM.

WARNING:

If you continue, the secondary disk operating system partitions will be overwritten with data from the CD-ROM and its MHD partitions are preserved.

Do you want to continue? (yes/no) **yes**

This task will take approximately 30 minutes. Answer **yes** if the following question is asked:

Do you want to change /etc/vfstab to make the secondary disk bootable? **yes**

When it is completed, you will be prompted to press **Return**. When the prompt appears, press **Return**.

7. From the main menu, select "Display the Workstation Default Boot Disk".

Is the default boot device set to the desired disk?

If **YES**, enter return and proceed with Step 9

If **NO**, enter return and proceed with Step 8.

8. From the main menu, select "Change the Workstation Default Boot Disk". If given multiple disks to choose from, select the appropriate task number to set the desired default boot disk:

Response:

- 1) Change the Workstation Default Boot Disk to Primary Disk
 - 2) Change the Workstation Default Boot Disk to Secondary Disk
 - 3) Return to the Main Menu
- Select task by number(1-3):

If prompted to set the primary disk as the default boot disk and the primary disk is the desired default boot disk, enter **yes**:

Response:

Do you want to change the default boot device to the primary disk (disk0)? **yes**

If prompted to set the secondary disk as the default boot disk and the secondary disk is the desired default boot disk, enter **yes**:

Response:

Do you want to change the default boot device to the secondary disk (disk1)? **yes**

9. From the main menu, select "Boot the Workstation on the Default Boot Disk". Answer **yes** to the confirmation. If you select a task by mistake, answer **no** to the confirmation.

Response:

You have chosen to boot the workstation ...

Do you want to continue? (yes/no) **yes**

The AW will boot and automatically start the AM emulator.

10. Is the system booted and running the emulated AM environment ?

If **YES**, STOP. YOU HAVE COMPLETED THIS PROCEDURE.

If **NO**, seek technical assistance.

4.6 Replace System Unit (*Netra*¹ t 1120 or *Netra* 20)

OVERVIEW

This procedure is used to replace the Administrative Workstation (AW). Before replacing the AW, preliminary checks should be performed to ensure that the cause of failure has not resulted from power becoming unavailable to the unit, the power switch inadvertently placed to the off position, or the failure of a peripheral (*Ethernet*², Serial Asynchronous, or High Speed) interface cable.

Note: This procedure assumes action has been taken to verify the failure is not caused by a failure of one or both disk drives in the AW. Procedure 4.5.1, 4.5.2, or 4.5.3 should be followed to replace a defective disk drive.

Caution: *Follow proper ESD grounding procedures when handling AW units. Wear an antistatic wrist strap. Handle disk drives by their sides and store ESD-sensitive components in antistatic containers.*

PROCEDURE

1. If the AW is operational, continue to Step 2. Otherwise skip to Step 5.
2. Backup the AW operating system to disk and tape. See "Backup Administrative Workstation Operating System," Procedure 4.4).
3. Make full office backup tapes (see 235-105-210, **5ESS**[®] *Switch Routine Operations and Maintenance Procedures*).
4. Halt the system (see "Halt the Administrative Workstation," Procedure 4.2).
5. Remove power to the AW. See "Remove Power to Administrative Workstation," Procedure 4.7.
6. Remove and label the cables connected to the rear of the AW.
 - DC power cables A and B. See Figure 4.6-1 (*Netra* t 1120) or 4.6-2 (*Netra* 20).
 - Serial Asynchronous Interface cable (one or two equipped). See Figure 4.6-3 (*Netra* t 1120) or 4.6-4 (*Netra* 20).
 - *Ethernet* Interface cables. See Figure 4.6-5 (*Netra* t 1120) or 4.6-6 (*Netra* 20).
 - Serial A and Serial B cables. See Figure 4.6-7 (*Netra* t 1120) or 4.6-8 (*Netra* 20).
 - ROP parallel cable. See Figure 4.6-10 (*Netra* t 1120) or 4.6-9 (*Netra* 20).
 - High Speed Interface cable. See Figure 4.6-11 (*Netra* t 1120) or 4.6-12 (*Netra* 20).

1. Trademark of Sun Microsystems, Inc.

2. Registered trademark of Xerox Corporation.

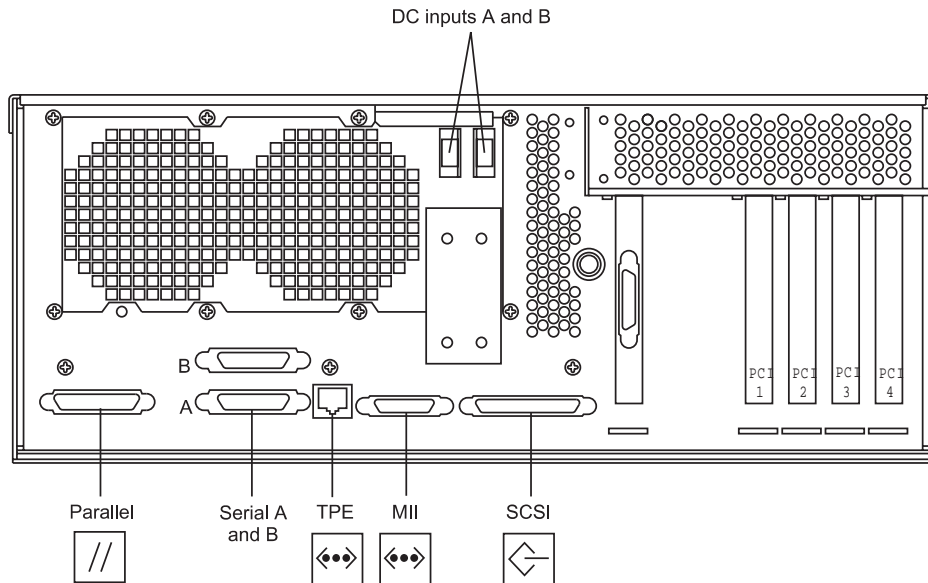

Figure 4.6-1 — Administrative Workstation Interface Configuration (*Netra t 1120*)

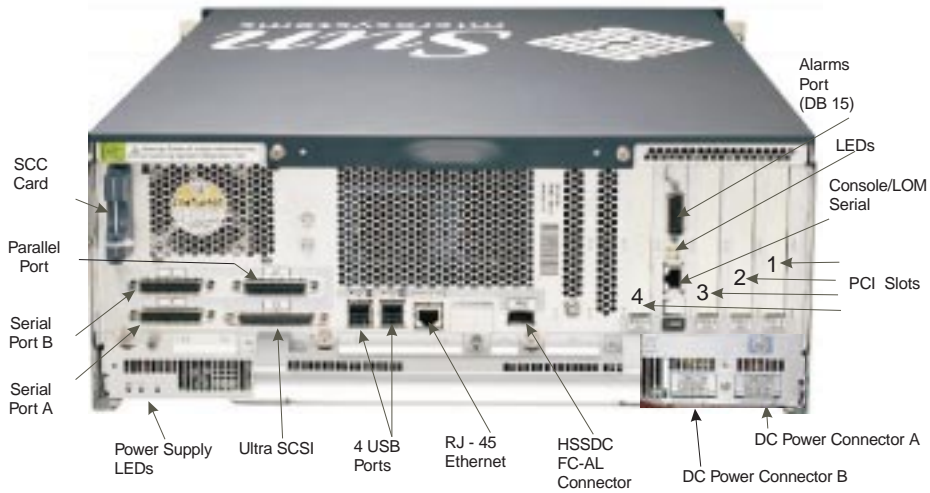

Figure 4.6-2 — Administrative Workstation Interface Configuration (*Netra 20*)

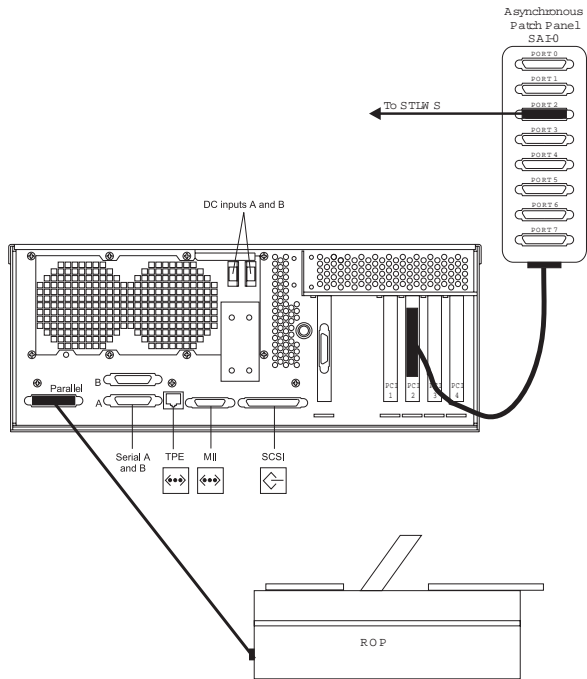

Figure 4.6-3 — Serial Asynchronous Interface (SAI) for *Netra t 1120*

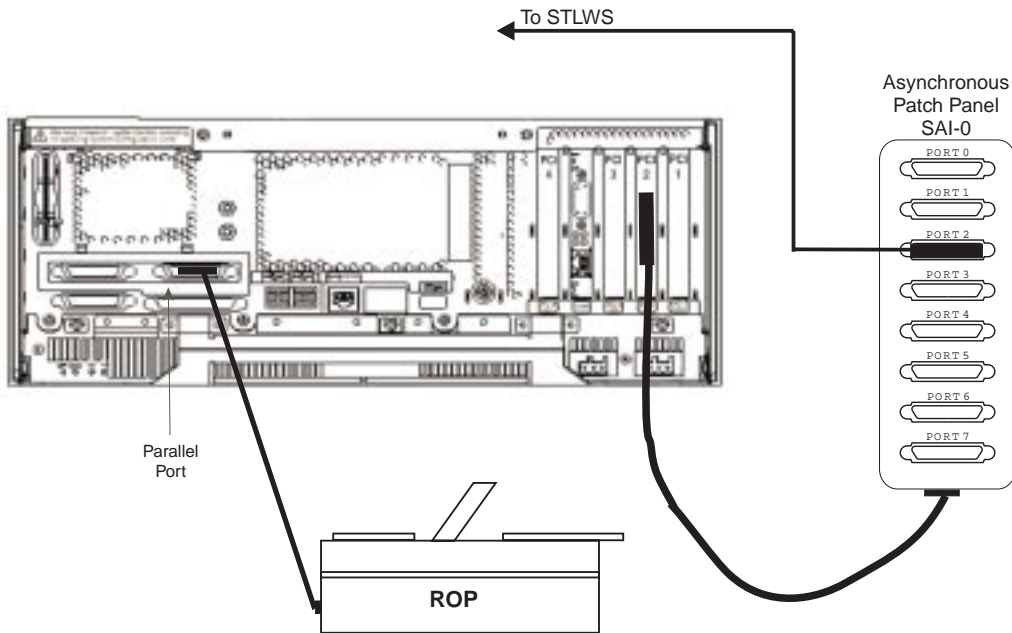

Figure 4.6-4 — Serial Asynchronous Interface (SAI) for *Netra 20*

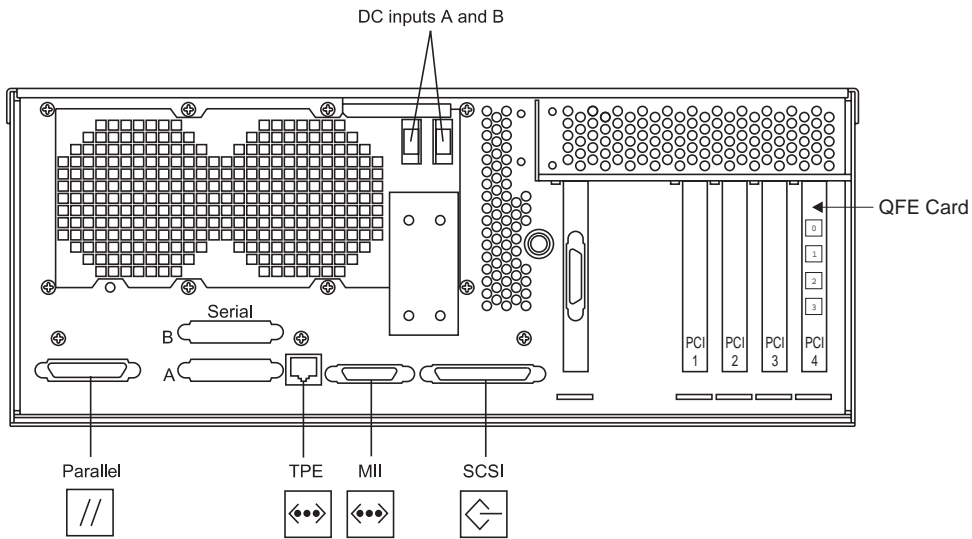

Figure 4.6-5 — Quad Fast Ethernet - Netra t 1120 Interface Connections

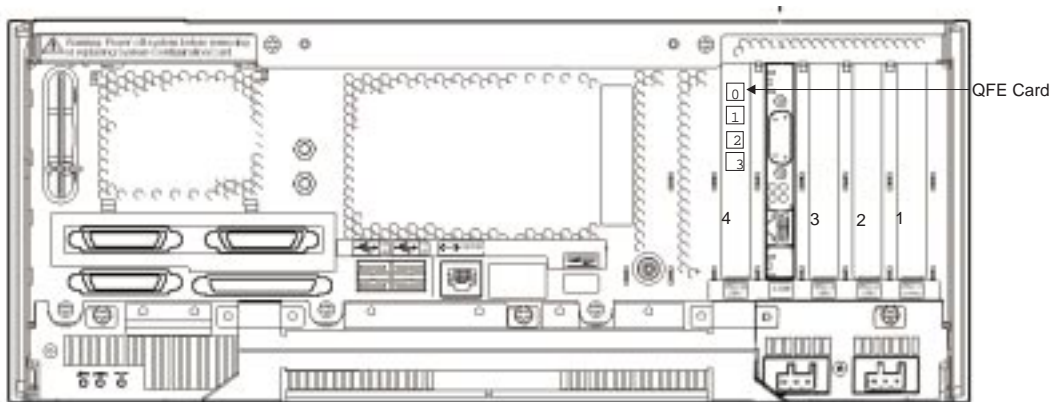

Figure 4.6-6 — Quad Fast Ethernet - Netra 20 Interface Connections

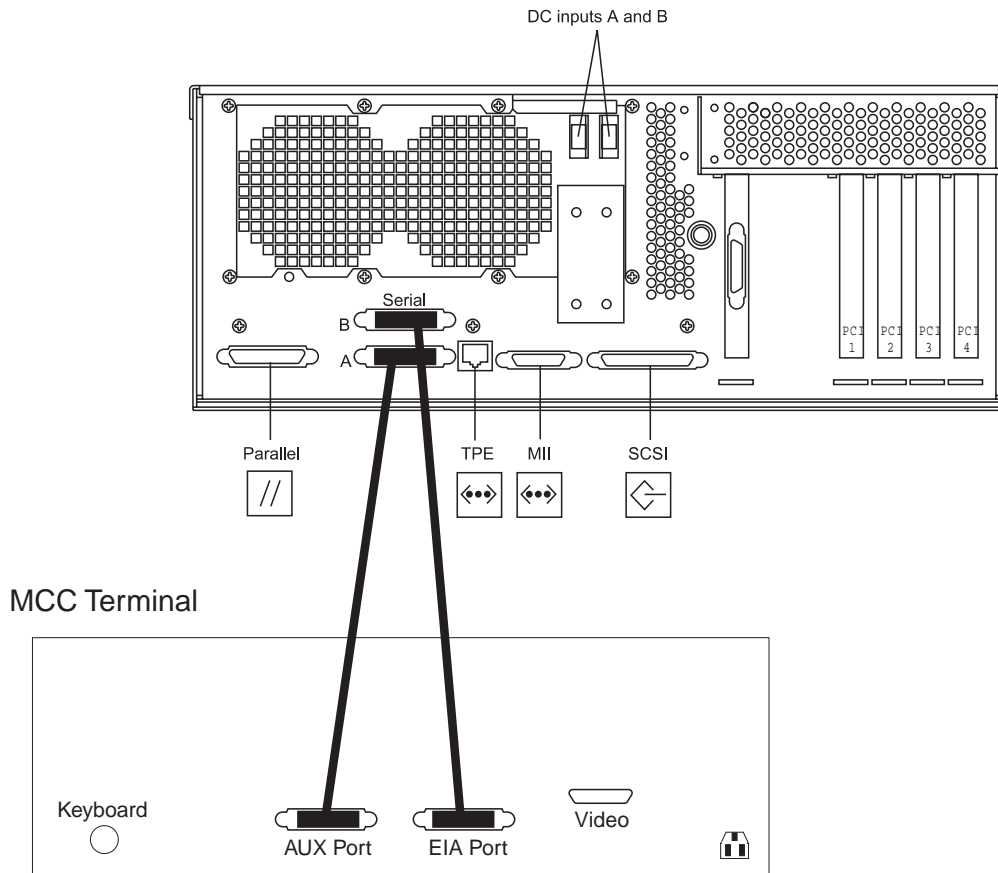

Figure 4.6-7 — MCC Interface to Administrative Workstation - *Netra t 1120*

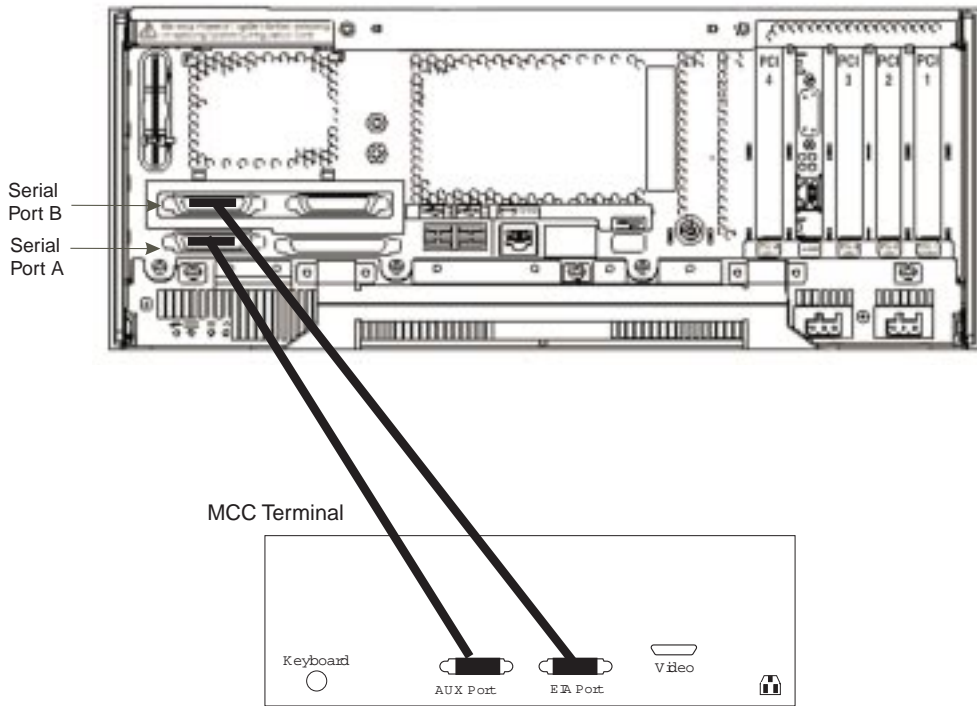

Figure 4.6-8 — MCC Interface to Administrative Workstation - *Netra 20*

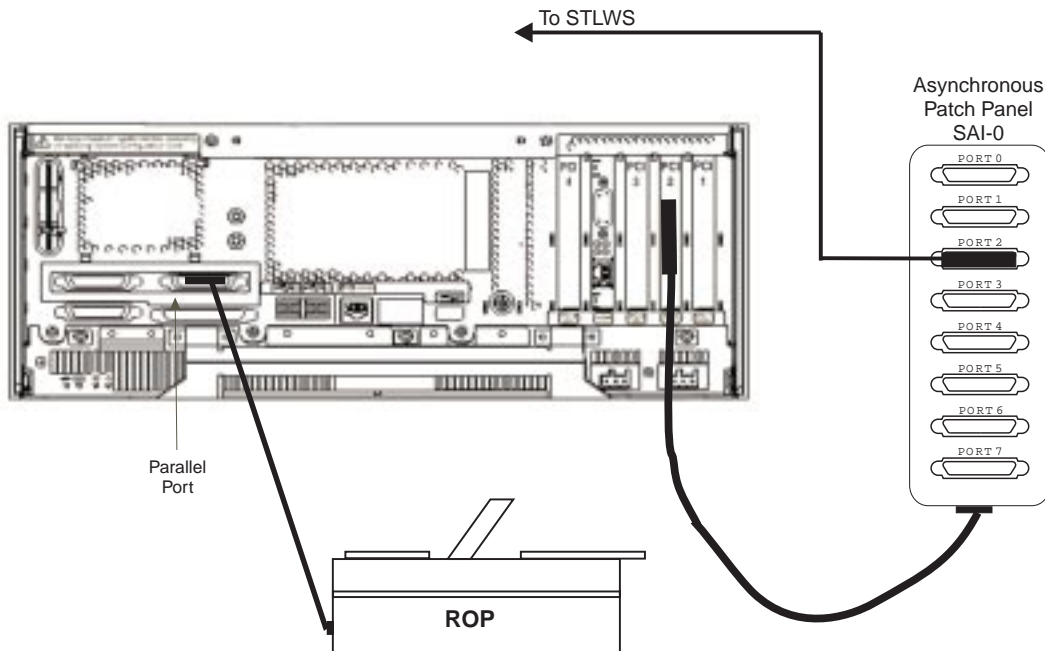

Figure 4.6-9 — STLWS and ROP Interface - *Netra 20*

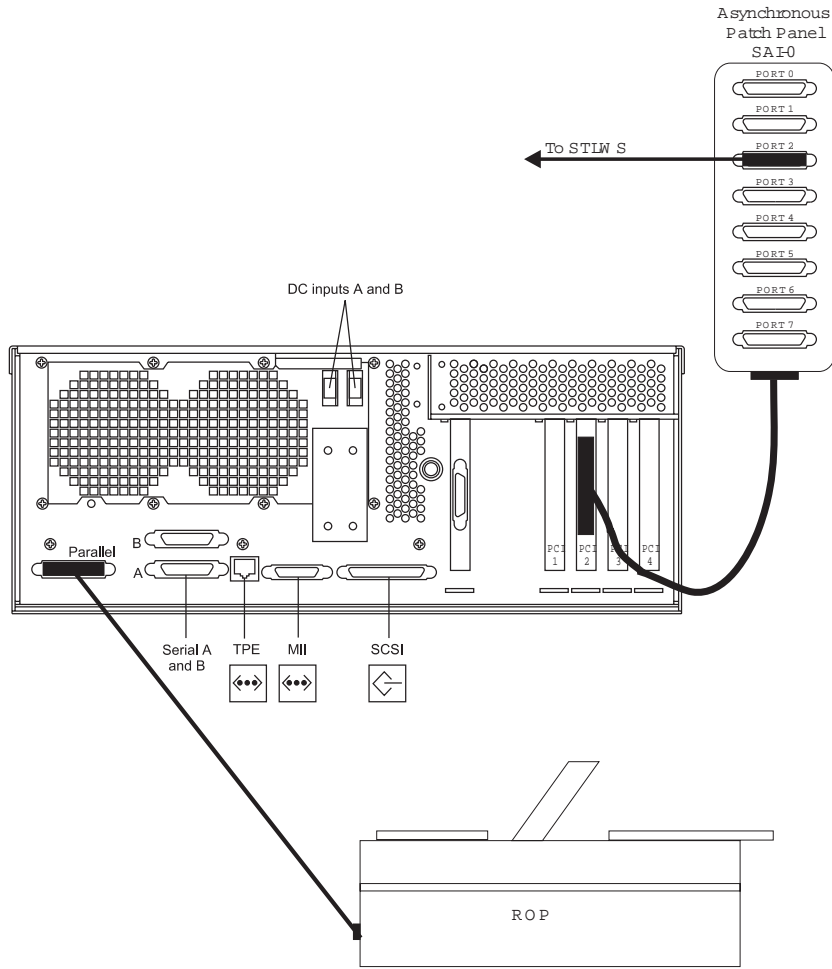

Figure 4.6-10 — STLWS and ROP Interface - Netra t 1120

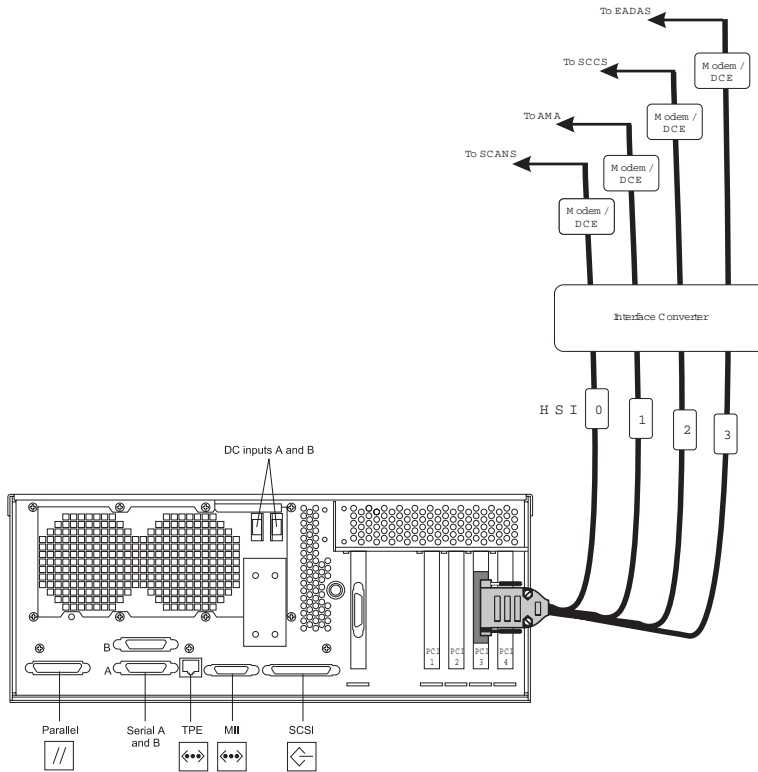

Figure 4.6-11 — SCANS/AMA/SCCS/Optional OSS Interface - Netra t 1120

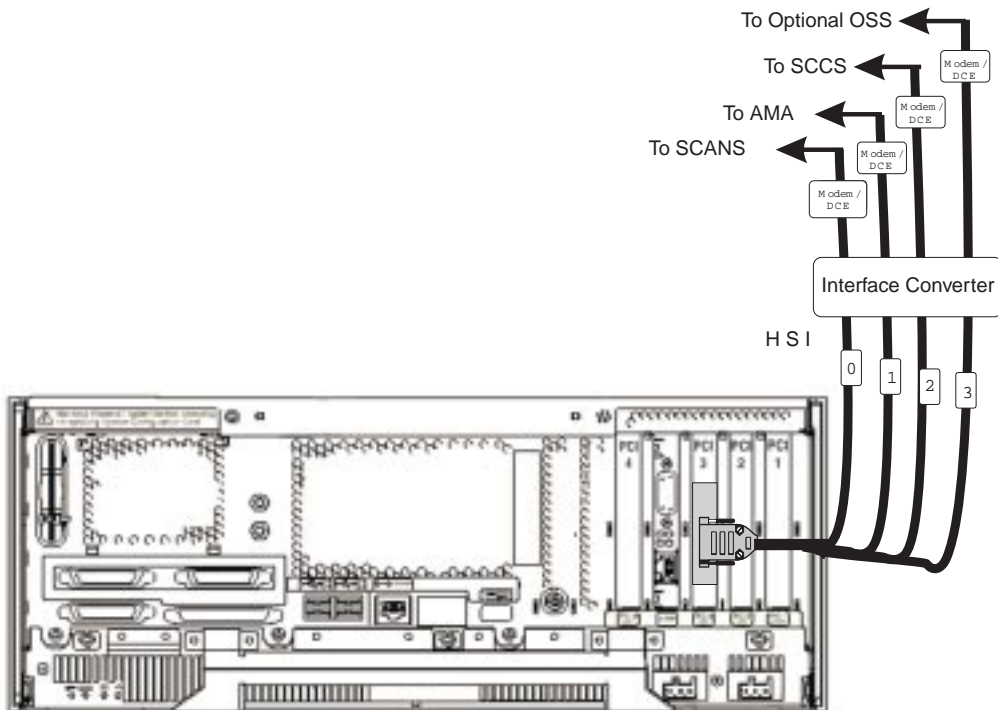

Figure 4.6-12 — SCANS/AMA/SCCS/Optional OSS Interface -Netra 20

7. Remove the mounting screws securing the AW to the frame. Save the screws for mounting the replacement AW to the frame.
8. Remove the AW from the frame by sliding the system forward.
9. Remove the mounting brackets from the AW. Save the screws and brackets for mounting the replacement AW to the frame.
10. Remove the disk drives from the AW that will be replaced.

For a *Netra t 1120*:

- Open the front access cover by twisting the two locking rings counter clockwise to the open position and lowering the front cover.
- Remove the front ESD plate (See Figure 4.6-13). Use a No.1 Phillips-head screwdriver to loosen the three retaining screws holding the ESD plate.
- Remove the primary disk drive from the lower disk drive slot by pushing the latch to the right, extending the drive handle, and pulling the disk from the drive bay.
- Label the disk. For example, "Office Primary Disk."
- Remove the secondary disk drive from the upper disk drive slot by pushing the latch to the right, extending the drive handle, and pulling the disk from the drive bay.
- Label the disk. For example, "Office Secondary Disk."

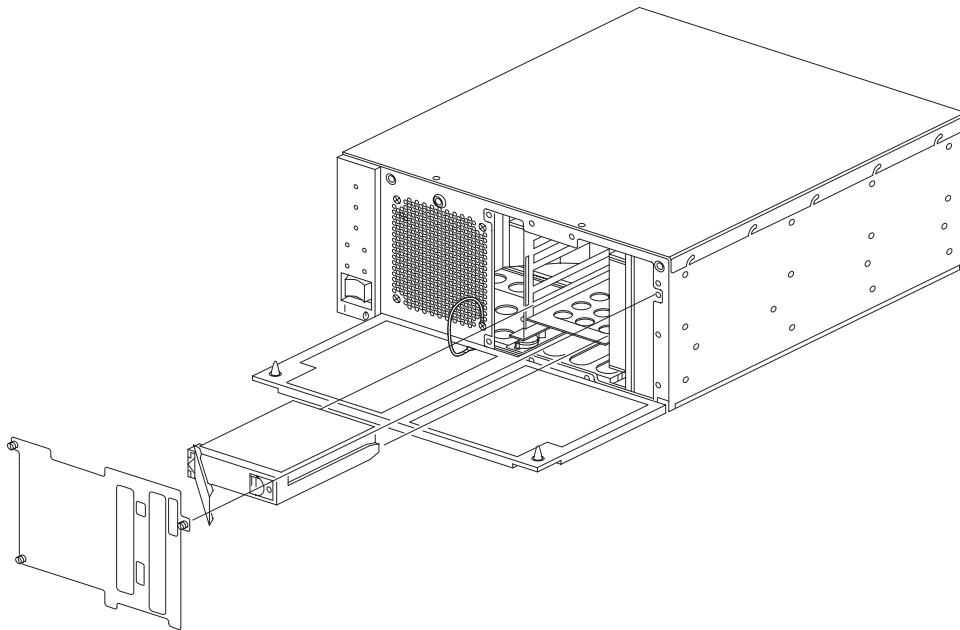

Figure 4.6-13 — Hard Disk Drive Location

For a *Netra 20*:

- Open the front access cover by pulling the cover away from the top of the AW chassis using the finger hold in the center of the cover.

- Remove the primary disk drive from the left disk drive slot (See Figure 4.6-14) by pushing the latch downward, extending the drive handle, and pulling the disk from the drive bay.
- Label the disk. For example, "Office Primary Disk."
- Remove the secondary disk drive from the right disk drive slot (See Figure 4.6-14) by pushing the latch downward, extending the drive handle, and pulling the disk from the drive bay.
- Label the disk. For example, "Office Secondary Disk."

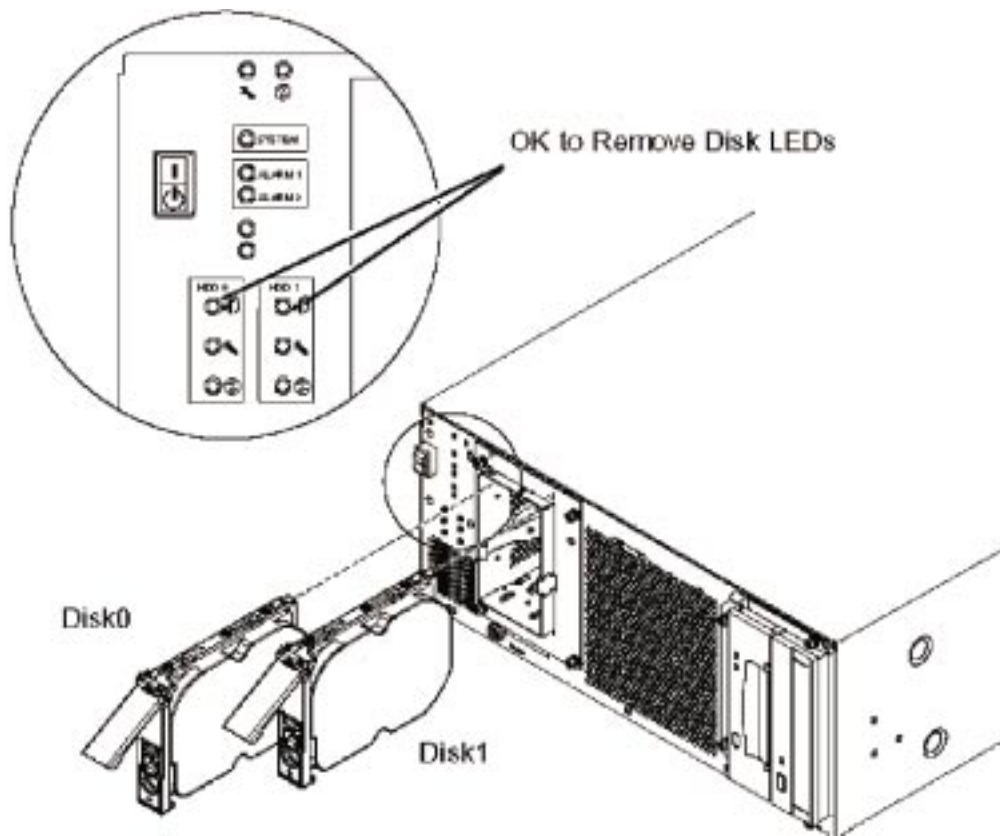

Figure 4.6-14 — Removal of the *Netra 20* Hard Drives

11. Repeat Step 10 to remove the disk drives from the replacement AW. Label these drives as "Spare Disk".
12. Install the disk drives, removed from the AW being replaced, into the replacement AW.

For a *Netra t 1120*:

- Holding the drive handle, insert the primary disk drive into the lower drive bay until contact is made with the backplane connector. Push the drive handle to lock the drive into the system.

- Holding the drive handle, insert the secondary disk drive into the upper drive bay until contact is made with the backplane connector. Push the drive handle to lock the drive into the system.
- Replace the front ESD plate using a No.1 Phillips-head screwdriver to tighten the three retaining screws holding the ESD plate.
- Replace the front access cover by lifting into place against the AW chassis and twisting the two locking rings clockwise to the lock position.

For a *Netra 20*:

- Holding the drive handle, insert the primary disk drive into the left drive bay until contact is made with the backplane connector. Push the drive handle to lock the drive into the system.
 - Holding the drive handle, insert the secondary disk drive into the right drive bay until contact is made with the backplane connector. Push the drive handle to lock the drive into the system.
 - Replace the front access cover by pressing the cover into place on the AW chassis.
13. Install the mounting brackets that were removed in Step 9 onto the replacement AW.
 14. Slide the AW into the mounting brackets on the frame.
 15. Secure the AW to the frame using the mounting screws that were removed in Step 7.
 16. Connect the cables that were removed in Step 6 to the rear of the replacement AW.
 17. Restore power to the AW. See "Restore Power to Administrative Workstation," Procedure 4.8.
 18. **STOP. YOU HAVE COMPLETED THIS PROCEDURE.**

4.7 Remove Power to Administrative Workstation (*Netra*¹ t 1120 and *Netra* 20)

OVERVIEW

Since all peripherals on the *Netra* t 1120 and *Netra* 20 are internal, the only power that needs to be removed is the System Power.

PROCEDURE

1. Be sure the AW has been "halted." If this has not already been done, see "Halt the Administrative Workstation," Procedure 4.2.
2. Remove power to the AW by pressing the ON/STBY switch on the front of the AW to the STBY "⏻" position and holding it until the system powers down.

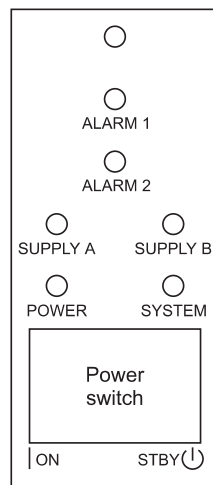

Figure 4.7-1 — *Netra* t 1120 Power Panel

1. Trademark of Sun Microsystems, Inc.

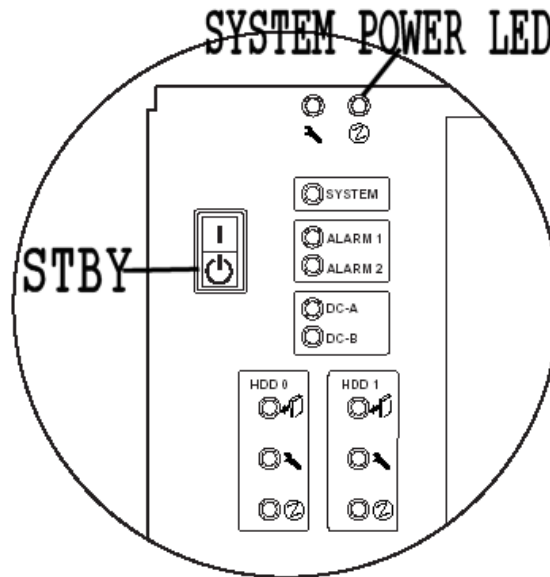

Figure 4.7-2 — Netra 20 Power Panel

Response: For a *Netra t 1120*, the green POWER, SUPPLY A, and SUPPLY B LEDs will no longer be lit.

For a *Netra 20*, the green system power LED, located on the upper left corner of the front cover, will no longer be lit. However, the green DC-A and DC-B LEDs will remain lit.

3. Open the circuit breaker for the DC power cables A and B connected to the rear of the AW. See Figures 4.7-3 (*Netra t 1120*) or 4.7-4 (*Netra 20*). To open the circuit breaker, push the fuse in while turning it counter clockwise, and pull the fuse out. The fuse-alarm LED above the fuse will be lit once the fuse is no longer seated.
4. Detach the DC power cables A and B from the AW. See Figure 4.7-3 (*Netra t 1120*) or 4.7-4 (*Netra 20*).

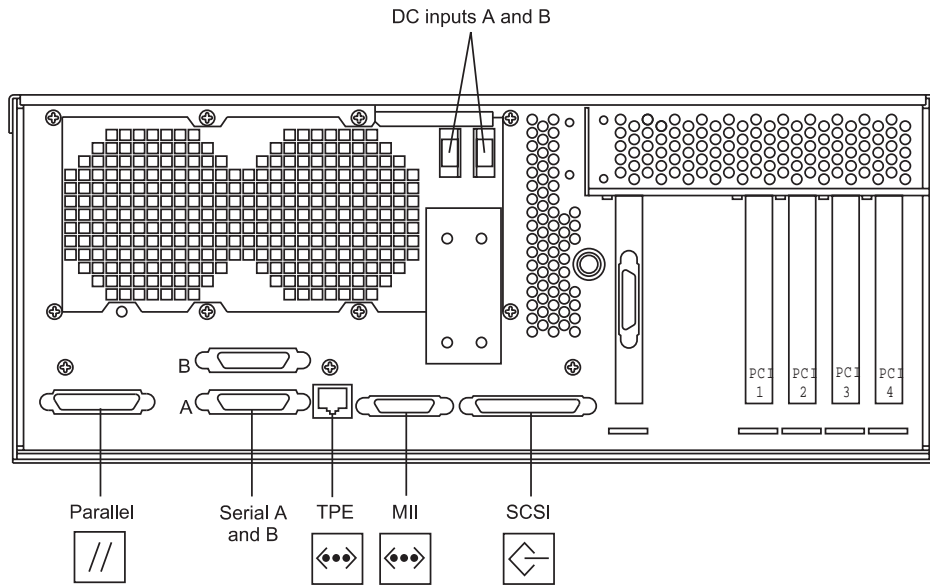

Figure 4.7-3 — Administrative Workstation Interface Configuration (*Netra t 1120*)

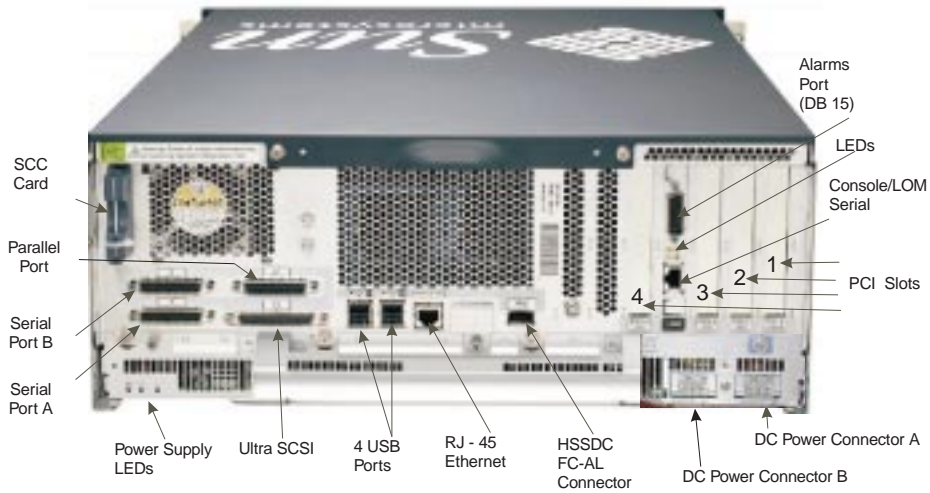

Figure 4.7-4 — Administrative Workstation Interface Configuration (*Netra 20*)

5. STOP. YOU HAVE COMPLETED THIS PROCEDURE.

4.8 Restore Power to Administrative Workstation (*Netra*¹ t 1120 and *Netra* 20)

OVERVIEW

Since all peripherals on the *Netra* t 1120 and *Netra* 20 are internal, the only power that needs to be restored is the System Power.

PROCEDURE

1. Connect the DC power cables A and B to the AW. See Figure 4.8-1 (*Netra* t 1120) or 4.8-2 (*Netra* 20).

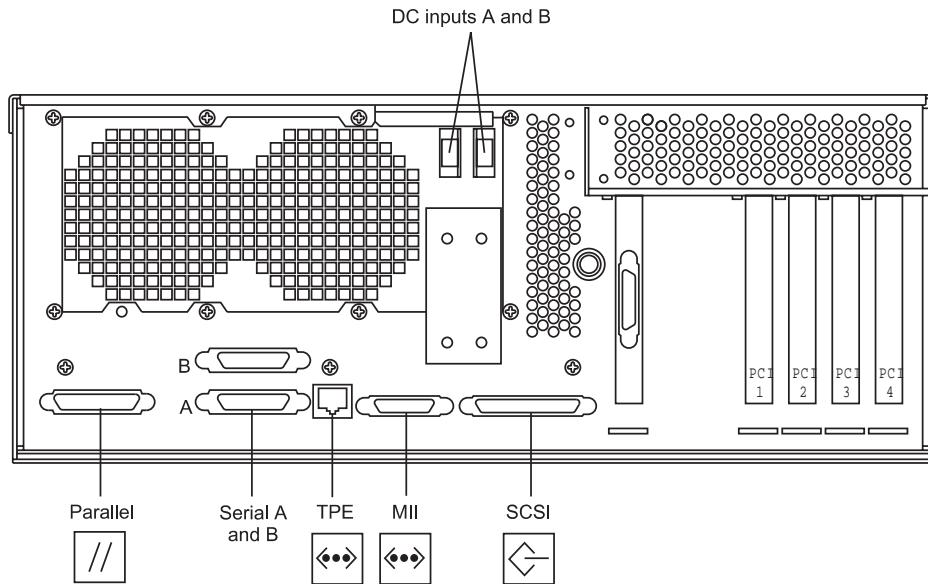

Figure 4.8-1 — Administrative Workstation Interface Configuration (*Netra* t 1120)

1. Trademark of Sun Microsystems, Inc.

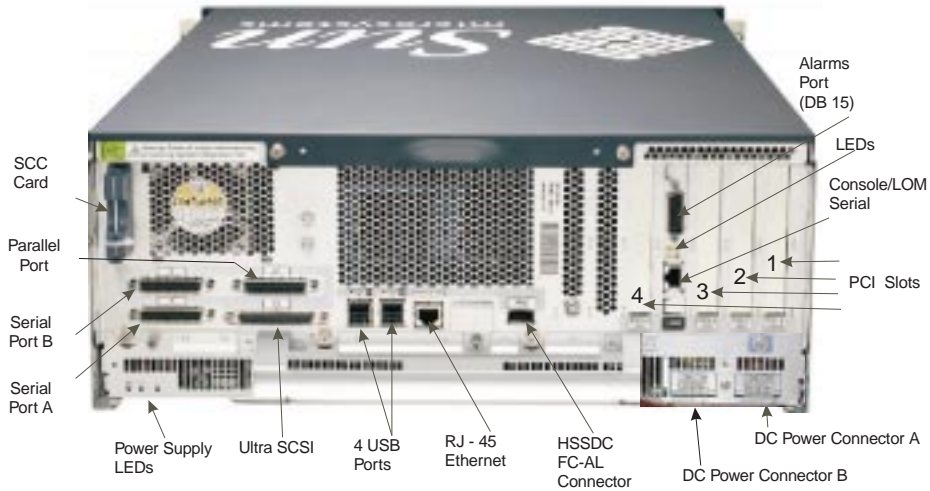

Figure 4.8-2 — Administrative Workstation Interface Configuration (Netra 20)

2. Close the circuit breakers for the DC power cables A and B. To close the circuit breaker, insert the fuse by pushing in the fuse while turning it clockwise. The fuse-alarm LED above the fuse will no longer be lit when the fuse is properly seated.
3. Restore power to the AW by pressing the ON/STBY switch on the front of the AW to the ON “ | ” position and holding it until the system starts to power up.

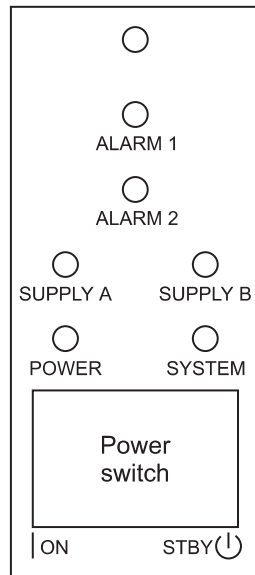

Figure 4.8-3 — Netra 1120 Power Panel

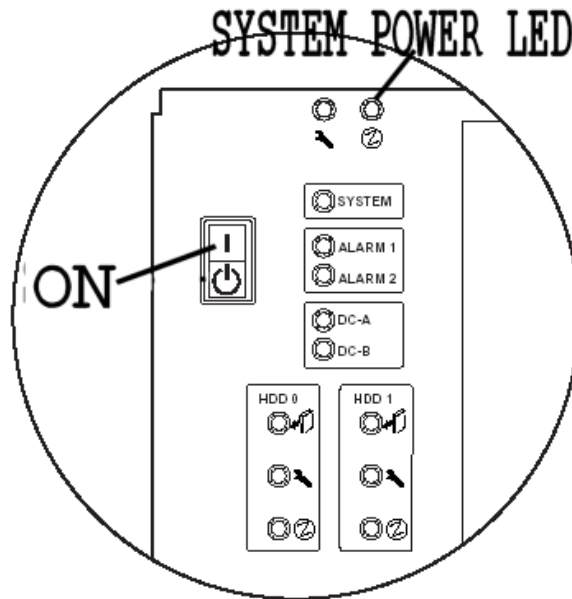

Figure 4.8-4 — Netra 20 Power Panel

- Response: For a *Netra t 1120*, the green POWER, SUPPLY A, and SUPPLY B LEDs will be lit.
For a *Netra 20*, the green system power LED, located on the upper left corner of the front cover, will be lit.
4. The AW will automatically boot on the 3B21 Emulator and Operating System software.
 5. **STOP. YOU HAVE COMPLETED THIS PROCEDURE.**

4.9 Remove Power to Administrative Workstation Units (*Netra*¹ 240)

OVERVIEW

This procedure will remove power from the *Netra* 240 AW and the external DAT tape drive.

PROCEDURE

1. Be sure the AW has been halted. If this has not already been done, see "Halt the Administrative Workstation," Procedure 4.2.
2. Remove power to the DAT tape drive unit. See "Remove Power to DAT Tape Drive Unit (*Netra* 240)", Procedure 4.15.
3. Remove power to the AW by pressing the ON/STBY switch "" on the front of the AW and holding it until the system powers down. The green system power LED, located on the upper left corner of the front cover, will no longer be lit.
4. Open the circuit breaker for the DC power cables A and B connected to the rear of the AW. See Figure 2-7. To open the circuit breaker, push the fuse in while turning it counter clockwise, and pull the fuse out. The fuse-alarm LED above the fuse will be lit once the fuse is no longer seated.
5. Detach the DC power cables A and B from the rear of the AW. See Figure 2-7.
6. **STOP. YOU HAVE COMPLETED THIS PROCEDURE.**

1. Registered trademark of Sun Microsystems, Inc.

4.10 Restore Power to Administrative Workstation Units (*Netra*¹ 240)

OVERVIEW

This procedure will restore power to the *Netra* 240 AW and the external DAT tape drive.

PROCEDURE

1. Restore power to the DAT tape drive unit. See "Restore Power to DAT Tape Drive Unit (*Netra* 240)", Procedure 4.16.
2. Connect the DC power cables A and B to the AW. See Figure 2-7.
3. Close the circuit breakers for the DC power cables A and B. To close the circuit breaker, insert the fuse by pushing in the fuse while turning it clockwise. The fuse-alarm LED above the fuse will no longer be lit when the fuse is properly seated.
4. Restore power to the replacement AW by pressing the ON/STBY switch "" on the front of the AW and holding it until the system starts to power up. The green system power LED, located on the upper left corner of the front cover, will be lit.
5. The AW will automatically boot on the 3B21 Emulator and Operating System software.
6. **STOP. YOU HAVE COMPLETED THIS PROCEDURE.**

1. Registered trademark of Sun Microsystems, Inc.

4.11 Replace a DAT or CD-ROM/DVD Drive (*Netra*¹ t 1120)

OVERVIEW

The DAT tape drive and the CD-ROM/DVD drive are built into the AW. Therefore, the AW must be halted before any maintenance on these drives can be performed.

Caution: Follow proper ESD grounding procedures when handling AW units. Wear an antistatic wrist strap and store ESD-sensitive components in antistatic containers.

PROCEDURE

1. Remove power to the AW. See "Remove Power to Administrative Workstation (*Netra* t 1120 and *Netra* 20)," Procedure 4.7.
2. Open the top cover of the AW.

Note: If the top cover is not accessible when mounted, the unit may need to be completely removed from the frame. See "Replace System Unit (*Netra* t 1120 or *Netra* 20)", Procedure 4.6.

- a. Remove the two screws from the front of the top cover. See Figure 4.11-1.
- b. Pull the top cover tab from the back of the system and lift the cover off.

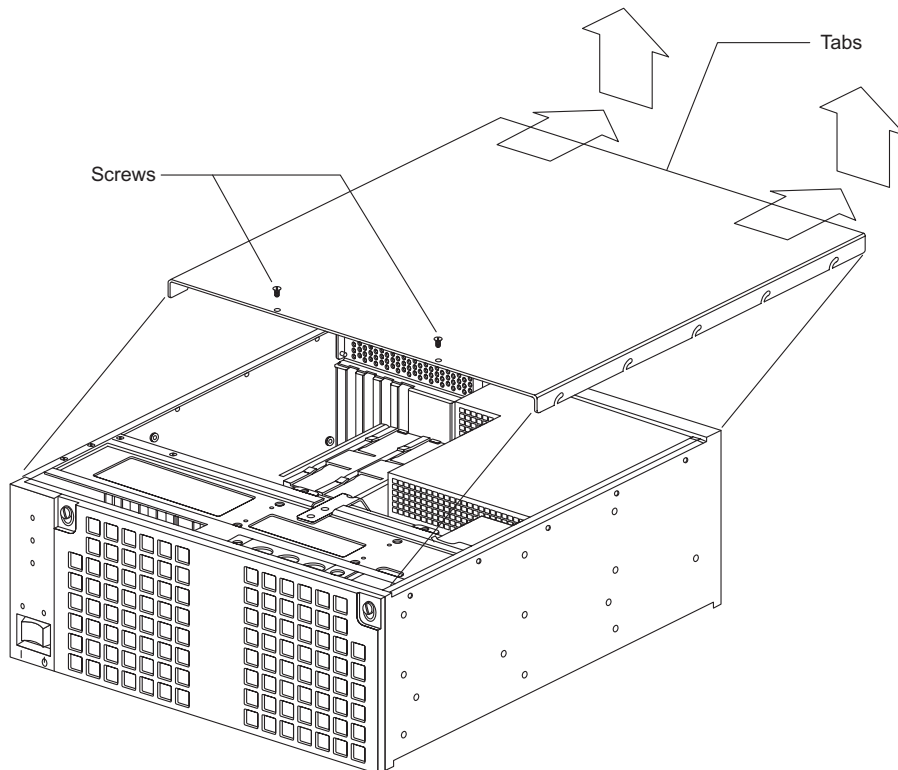

Figure 4.11-1 — Removal of the *Netra* t 1120 Top Cover

3. Open the front access cover by twisting the two locking rings counter clockwise to the open position and lowering the front cover.

1. Trademark of Sun Microsystems, Inc.

4. Remove the front ESD plate (see Figure 4.11-2). Use a No.1 Phillips-head screwdriver to undo the two or three captive screws.

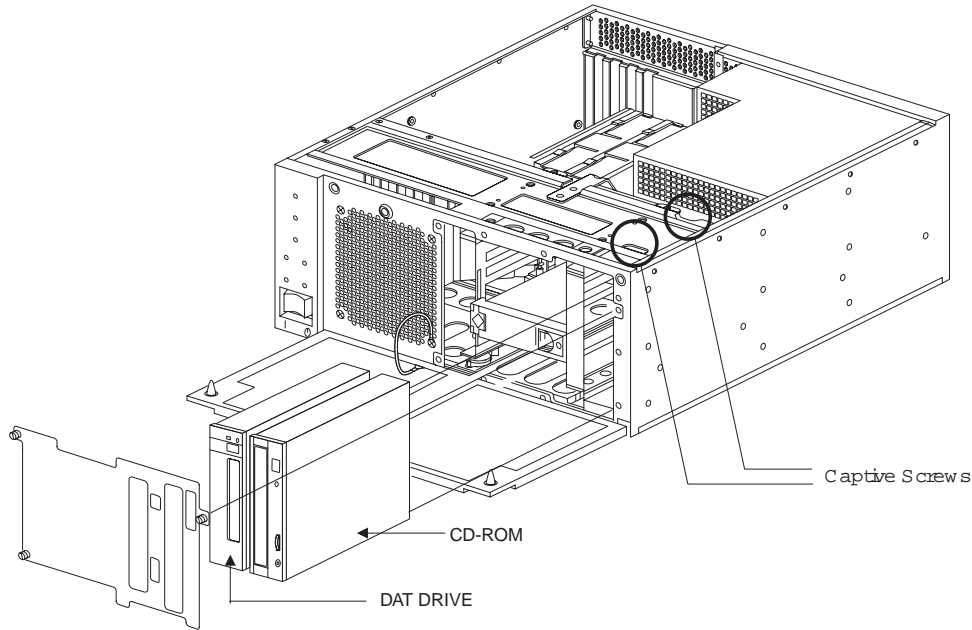

Figure 4.11-2 — Removal of the Netra t 1120 CDROM/DVD and DAT Drive

5. Loosen the four captive screws on top of the DAT or CD-ROM/DVD drive that will be replaced. If a CD-ROM/DVD drive is being replaced, partially slide the drive out from the chassis to allow access to the SCSI bus and power connectors.
6. Disconnect the SCSI bus and power connectors from the rear of the DAT or CD-ROM/DVD drive.
7. Pull the DAT or CD-ROM/DVD drive out from the front of the AW chassis.
8. Make sure that all jumper connectors on the set of pins located near the SCSI bus and power connectors at the rear of the replacement DAT or CD-ROM/DVD drive match the jumper connectors on the rear of the drive being replaced.
Note: The SCSI ID is set using jumper connectors on the set of pins at the rear of the drive. The jumper connectors must be configured so that the SCSI ID for the DAT drive is set to 4 and the SCSI ID of the CD-ROM/DVD drive is set to 5.
9. Insert the replacement DAT or CD-ROM/DVD drive into the AW chassis so that the eject button is at the top right hand side of the faceplate.
10. Connect the SCSI and power cables to the rear of the replacement DAT or CD-ROM/DVD drive.
11. Tighten the four captive screws securing the replacement DAT or CD-ROM/DVD drive to the drive assembly.
12. Replace the front ESD plate using a No.1 Phillips-head screwdriver to tighten the three captive screws holding the ESD plate.

13. Replace the front access cover by lifting into place against the AW chassis and twisting the two locking rings clockwise to the lock position.
14. Replace the top cover of the AW.
 - a. Position the cover over the system with the screw holes at the front and the slots on each side lined up with the lugs on the sides of the AW.
 - b. Push the cover forwards until the lugs on the sides are locked in the slots.
 - c. Replace the screws on the front of the cover.

Note: If the AW was removed from the frame Step 3, install the AW into the frame. See "Replace System Unit (*Netra t 1120* or *Netra 20*)", Procedure 4.6.
15. Restore power to the AW. See "Restore Power to Administrative Workstation (*Netra t 1120* or *Netra 20*)", Procedure 4.8.
16. **STOP. YOU HAVE COMPLETED THIS PROCEDURE.**

4.12 Replace a DAT or DVD Drive (*Netra*¹ TM 20)

OVERVIEW

The DAT tape drive and the DVD drive are built into the AW. Therefore, the AW must be halted before any maintenance on these drives can be performed.

Caution: *Follow proper ESD grounding procedures when handling AW units. Wear an antistatic wrist strap and store ESD-sensitive components in antistatic containers.*

PROCEDURE

1. Remove power to the AW. See "Remove Power to Administrative Workstation (*Netra* t 1120 or *Netra* 20)", Procedure 4.7.
2. Open the top cover of the AW.

Note: If the top cover is not accessible when mounted, the AW may need to be completely removed from the frame. See "Replace System Unit (*Netra* t 1120 or *Netra* 20)", Procedure 4.6.

- a. Loosen the two captive screws from the rear of the top cover. See Figure 4.12-1)
- b. Pull the top cover tab from the back of the system to disengage the lugs and lift it off.

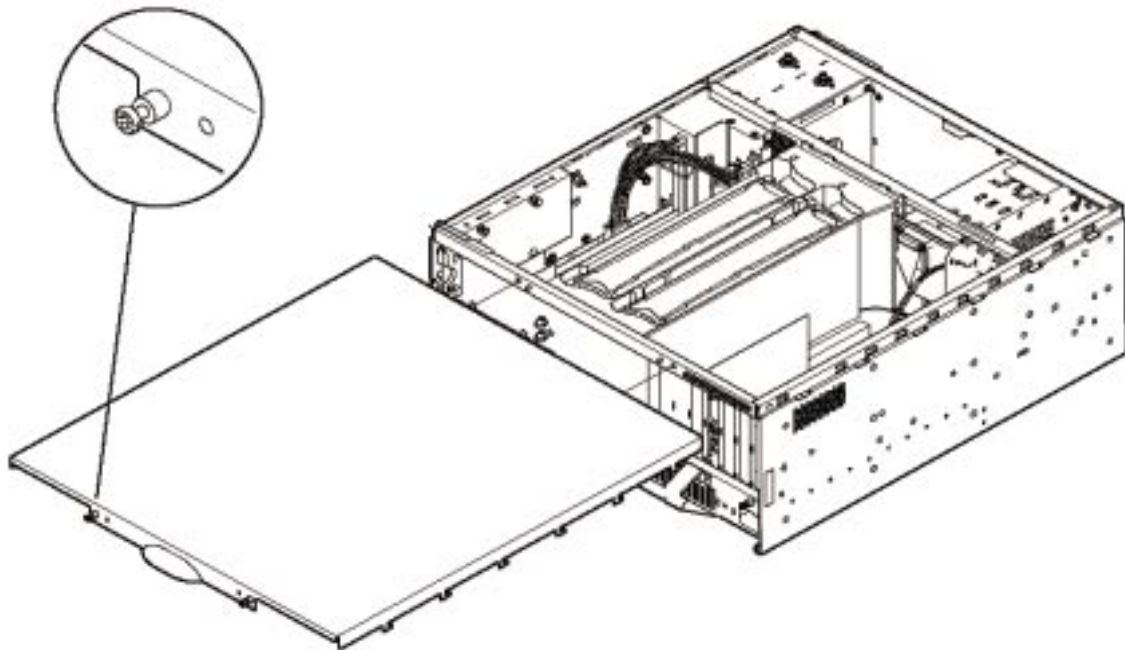

Figure 4.12-1 — Removal of *Netra* 20 Top Cover

1. Trademark of Sun Microsystems, Inc.

3. Open the front access cover by pulling the cover away from the top of the AW chassis using the finger hold in the center of the cover.
4. Loosen the two captive screws on top of the DAT or DVD drive that will be replaced. See Figure 4.12-2.

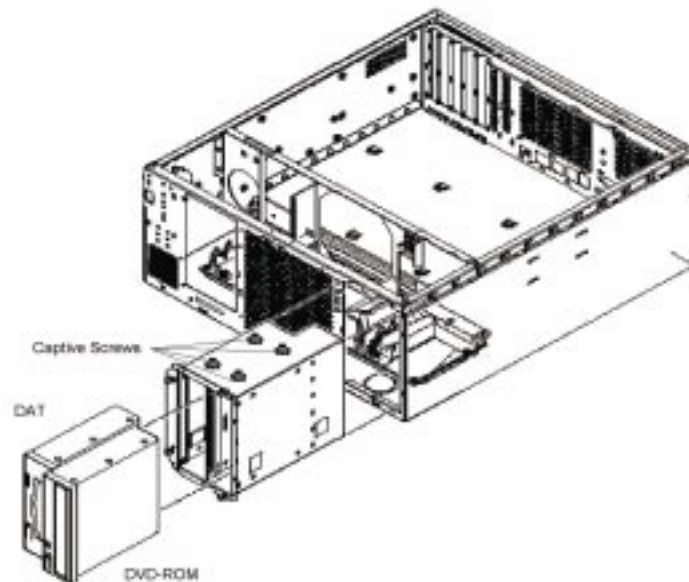

Figure 4.12-2 — Removal of *Netra 20* DAT or DVD

5. Disconnect the SCSI and power connectors from the rear of the DAT or DVD drive.
6. Pull the DAT or DVD drive out from the front of the AW chassis.
7. Make sure that all jumper connectors on the set of pins located near the SCSI bus and power connectors at the rear of the replacement DAT or CD-ROM/DVD drive match the jumper connectors on the rear of the drive being replaced.
Note: The SCSI ID is set using jumper connectors on the set of pins at the rear of the drive. The jumper connectors must be configured so that the SCSI ID for the DAT drive is set to 5 and the SCSI ID of the CD-ROM/DVD drive is set to 6.
8. Insert the replacement DAT or DVD drive into the AW chassis so that the eject button is at the bottom left hand side of the faceplate.
9. Connect the SCSI and power cables to the rear of the replacement DAT or DVD drive.
10. Tighten the two captive screws securing the replacement DAT or DVD drive to the drive assembly.
11. Replace the front access cover by pressing the cover into place on the AW chassis.

12. Replace the top cover of the AW.
 - a. Position the cover over the system with the captive screws at the rear and the lugs on each side lined up with the slots on the sides of the AW.
 - b. Push the cover forwards until the lugs on the sides are locked in the slots.
 - c. Tighten the screws on the rear of the cover.

Note: If the AW was removed from the frame in Step 2, install the AW into the frame. See "Replace System Unit (*Netra t 1120* or *Netra 20*)", Procedure 4.6.
13. Restore power to the AW. See "Restore Power to Administrative Workstation (*Netra t 1120* or *Netra 20*)", Procedure 4.8.
14. **STOP. YOU HAVE COMPLETED THIS PROCEDURE.**

4.13 Replace System Unit (*Netra*¹ 240)

OVERVIEW

This procedure is used to replace the *Netra* 240 Administrative Workstation (AW). Before replacing the AW, preliminary checks should be performed to ensure that the cause of failure has not resulted from power becoming unavailable to the unit, the power switch inadvertently placed to the off position, or the failure of a peripheral (*Ethernet*², Serial Asynchronous, or High Speed) interface cable.

Note: This procedure assumes action has been taken to verify the failure is not caused by a failure of one or both disk drives in the AW. To replace a defective disk, see “Replace a Defective Primary Disk (*Netra* 240)”, Subprocedure 4.5.4 or “Replace a Defective Secondary Disk (*Netra* 240)”, Subprocedure 4.5.5.

Caution: *Follow proper ESD grounding procedures when handling AW units. Wear an antistatic wrist strap. Handle disk drives by their sides and store ESD-sensitive components in antistatic containers.*

PROCEDURE

1. If the AW is operational, continue to Step 2. Otherwise skip to Step 5.
2. Backup the AW operating system to disk and tape (see Backup Administrative Workstation Operating System,” Procedure 4.4).
3. Make full office backup tapes (see 235-105-210, **5ESS**[®]-2000 *Switch Routine Operations and Maintenance Procedures* Section 6.23 “Make Full Office Backup Tape”).
4. Halt the AW (see “Halt the Administrative Workstation,” Procedure 4.2).
5. Remove power to the AW (see “Remove Power to Administrative Workstation Units (*Netra* 240),” Procedure 4.9).
6. Remove and label the cables connected to the rear of the AW.
 - Serial Port DB-9 Cable
 - DAT72 SCSI Bus Cable
 - High Speed Interface PCI Card Cable
 - SCI PCI Cables
 - *Ethernet* Interface cables.
 - DC Power Input Cables to the Power Supply Units
7. Remove the mounting screws securing the AW to the frame. Save the screws for mounting the replacement AW to the frame.
8. Remove the AW from the frame by sliding the system forward.
9. Remove the mounting brackets from the AW. Save the screws and brackets for mounting the replacement AW to the frame.
10. Remove the disk drives from the AW that will be replaced.

1. Registered trademark of Sun Microsystems, Inc.

2. Registered trademark of Xerox, Corp.

- (a) Grip the bezel at the two finger holds and rotate it down to open (see Figure “*Netra 240 Front Fingerholds*”, 4.13-1).
- (b) Slide the catch at the front of the disk drive to the right (see Figure “*Netra 240 Disk Drive*”, 4.13-2).
- (c) Pull the handle and remove the disk drive from AW by sliding it out from its bay.

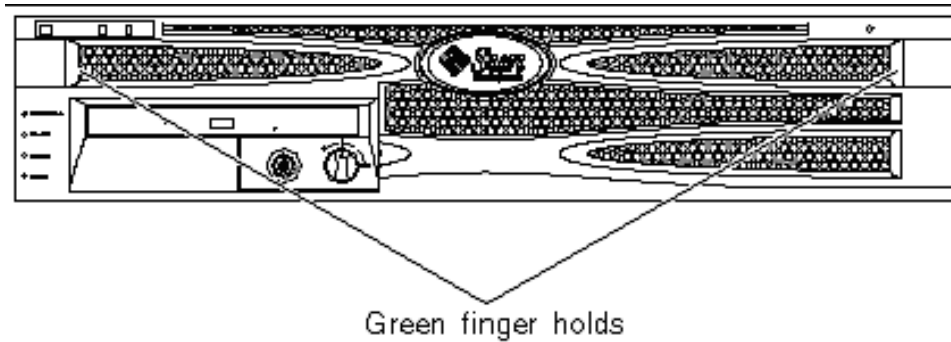

Figure 4.13-1 — NETRA 240 Front Fingerholds

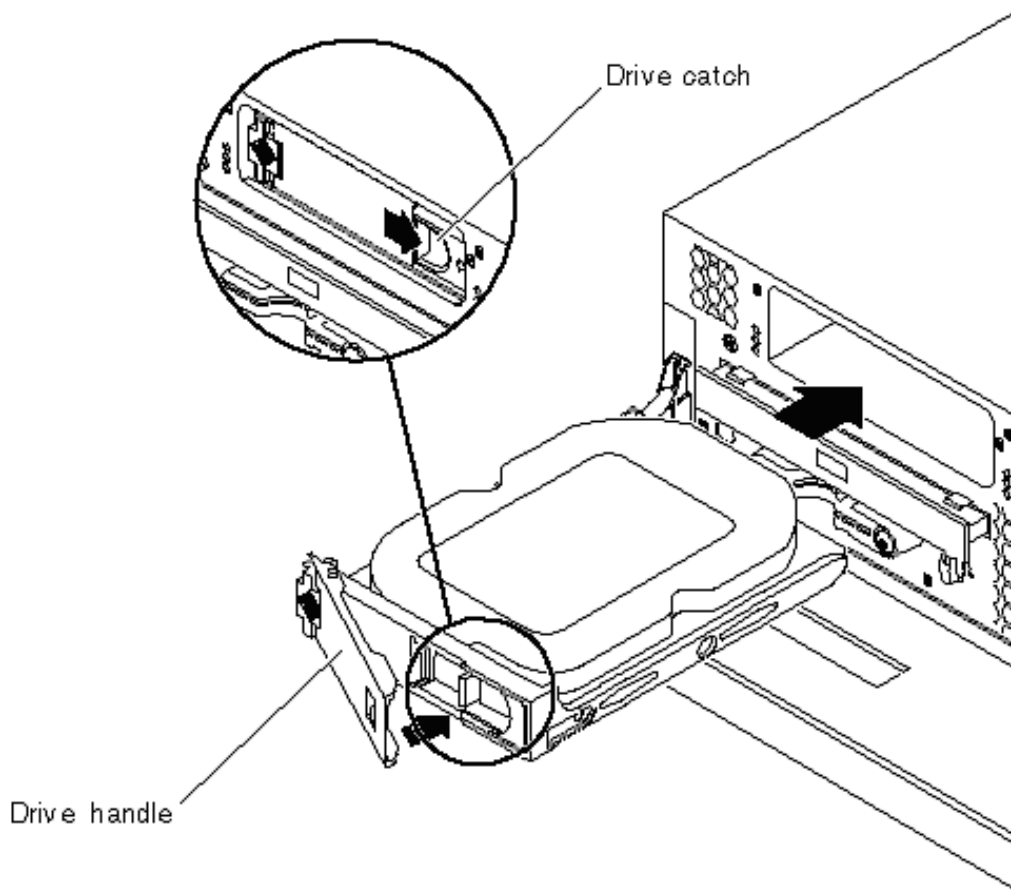

Figure 4.13-2 — NETRA 240 Disk Drive

11. Repeat Step 10 to remove the disk drives from the replacement AW. Label these drives as “Spare Disk”.
12. Install the disk drives, removed from the AW being replaced, into the replacement AW.
 - (a) Slide the catch on the front of the disk drive to the right (see Figure “*Netra 240 Disk Drive*”, 4.13-2).
 - (b) Slide the disk drive into its bay at the front of the server.
 - (c) Push the metal lever until the drive clicks into place.
 - (d) Close the bezel until it is locked in place.
13. Install the mounting brackets that were removed in Step 9 onto the replacement AW.
14. Slide the AW into the mounting brackets on the frame.
15. Secure the AW to the frame using the mounting screws that were removed in Step 7.

16. Connect the cables that were removed in Step 6 to the rear of the replacement AW.
17. Restore power to the AW (see “Restore Power to Administrative Workstation Units (*Netra 240*),” Procedure 4.10).
18. **STOP. YOU HAVE COMPLETED THIS PROCEDURE.**

4.14 Replace a DAT Tape Drive Unit (*Netra*¹ 240)

OVERVIEW

This procedure is used to replace a defective external DAT tape drive unit connected to the *Netra* 240 AW.

Before replacing the defective DAT tape drive unit, preliminary checks should be performed to ensure that the cause of failure has not resulted from loss of power to the unit or the failure of the SCSI cable connecting the unit to the AW.

Caution: *When performing maintenance on the DAT tape drive unit, personnel should be properly grounded, wearing a wrist strap connected to a frame ground or a designated ground connection point.*

PROCEDURE

1. Halt the AW (see "Halt the Administrative Workstation," Procedure 4.2).
2. Remove power to the DAT tape drive unit (see "Remove Power to DAT Tape Drive Unit (*Netra* 240)", Procedure 4.15).
3. Disconnect the SCSI cable from SCSI port A at the rear of the DAT tape drive unit. See Figure 4.14-1 (*Netra* 240 DAT Rear Panel).

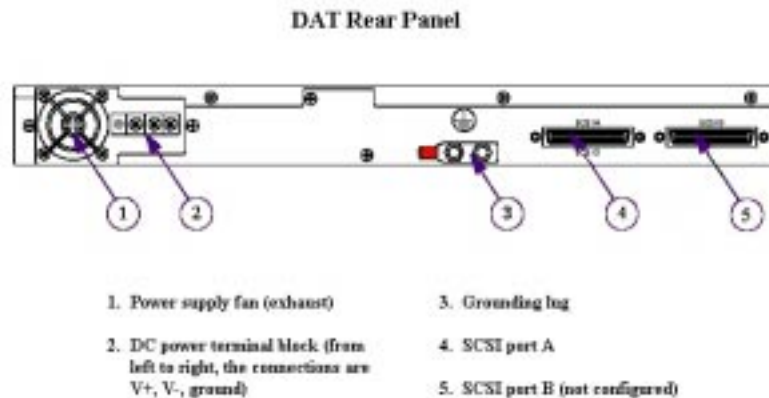

Figure 4.14-1 — NETRA 240 DAT Rear Panel

4. Remove the mounting screws securing the DAT tape drive unit to the mounting bracket. See Figure 4.14-2 (*Netra* 240 DAT Front Panel). Save the screws for mounting the replacement DAT tape drive unit to the mounting bracket.

1. Registered trademark of Sun Microsystems, Inc.

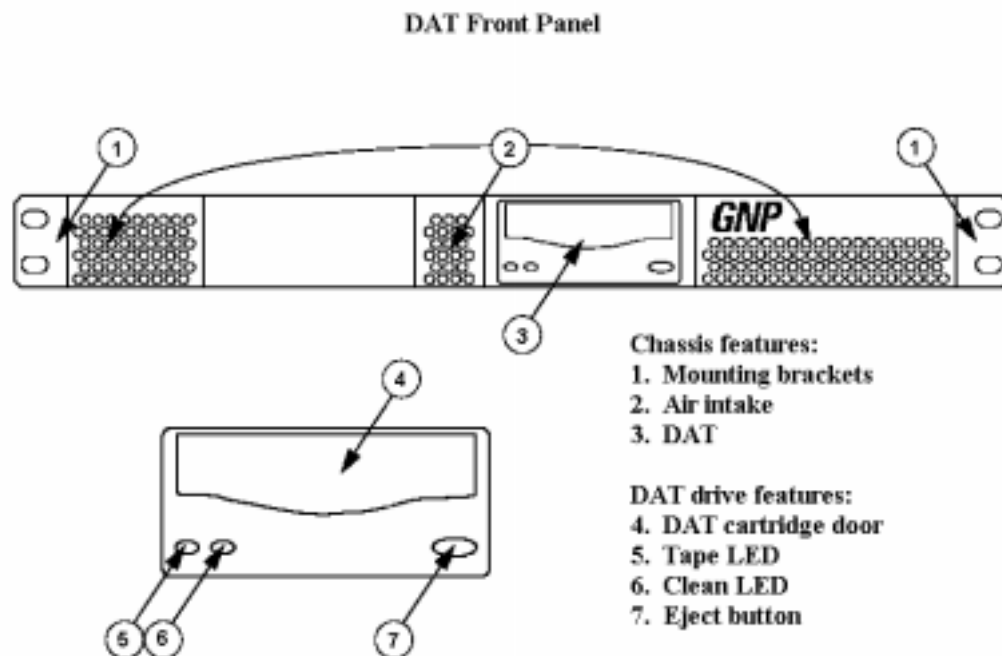

Figure 4.14-2 — NETRA 240 DAT Front Panel

5. Remove the DAT tape drive unit from the bracket attached to the frame by sliding the unit forward.
6. Slide the replacement DAT tape drive unit onto the mounting bracket attached to the frame.
7. Secure the replacement DAT tape drive unit to the mounting bracket using the mounting screws that were removed in Step 4. See Figure 4.14-2 (*Netra 240 DAT Front Panel*).
8. Reconnect the SCSI cable to SCSI port A at the rear of the replacement DAT tape drive unit. See Figure 4.14-1 (*Netra 240 DAT Rear Panel*).
9. Restore power to the DAT tape drive unit (see "Restore Power to DAT Tape Drive Unit (*Netra 240*)", Procedure 4.16).
10. Restore the AW (see "Restore Administrative Workstation", Procedure 4.3).

Result:

The AW will automatically boot on the 3B21 Emulator and Operating System software.

11. STOP. YOU HAVE COMPLETED THIS PROCEDURE.

4.15 Remove Power to DAT Tape Drive Unit (*Netra*¹ 240)

OVERVIEW

This procedure is used to remove power to the external DAT tape drive unit connected to the *Netra* 240 AW.

Caution: *When performing maintenance on the DAT tape drive unit, personnel should be properly grounded, wearing a wrist strap connected to a frame ground or a designated ground connection point.*

PROCEDURE

1. Remove power to the DAT tape drive unit by opening the circuit breaker for the DC power cable connected to the rear of the unit. To open the circuit breaker, push the fuse in while turning it counter clockwise, and pull the fuse out. The fuse-alarm LED above the fuse will be lit once the fuse is no longer seated.
2. Use a Philips screwdriver to remove the DC power cable connected to the rear of the unit. The DC power cable is connected to the rear of the unit at a terminal block (positive '+' and negative '-') and adjacent grounding lug. See Figures 4.15-1 (DAT Rear Panel) and 4.15-2 (*Netra* 240 DAT DC Power Connections).

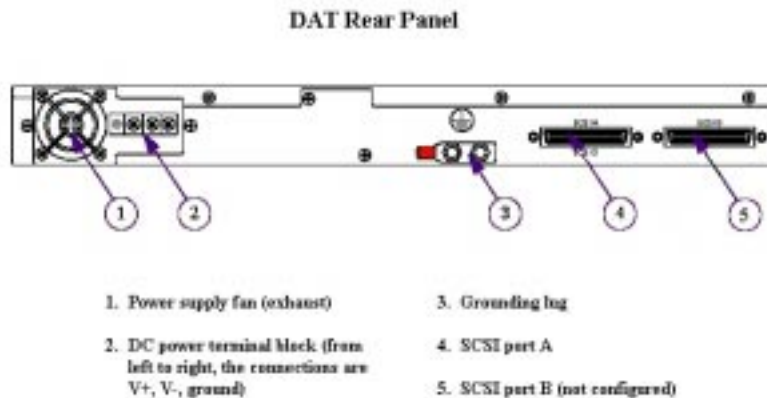

Figure 4.15-1 — NETRA 240 DAT Rear Panel

1. Registered trademark of Sun Microsystems, Inc.

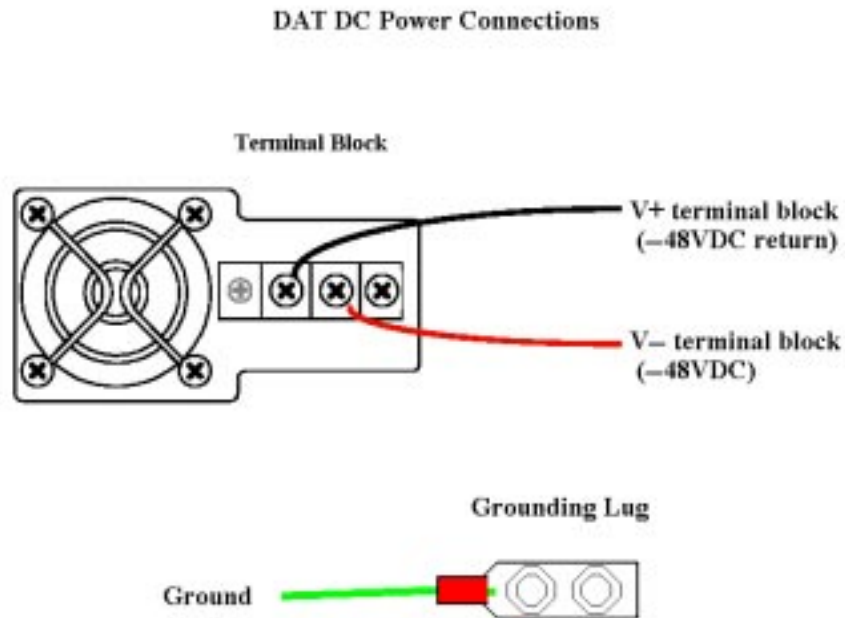

Figure 4.15-2 — NETRA 240 DAT DC Power Connections

- (a) Start by removing the power cable from the terminal block (positive '+' and negative '-').
 - (b) After the power cabling has been removed from the terminal block, remove the ground wire from the grounding lug.
3. **STOP. YOU HAVE COMPLETED THIS PROCEDURE.**

4.16 Restore Power to DAT Tape Drive Unit (*Netra*¹ 240)

OVERVIEW

This procedure is used to restore power to the external DAT tape drive unit connected to the *Netra* 240 AW.

Caution: *When performing maintenance on the DAT tape drive unit, personnel should be properly grounded, wearing a wrist strap connected to a frame ground or a designated ground connection point. Also, make sure that the circuit breaker for the DC power cable is open before starting this procedure.*

PROCEDURE

1. Use a Philips screwdriver to connect the DC power cable to the terminal block (positive '+' and negative '-') and adjacent grounding lug at the rear of the DAT tape drive unit. See Figures 4.16-1 (DAT Rear Panel) and 4.16-2 (DAT DC Power Connections).

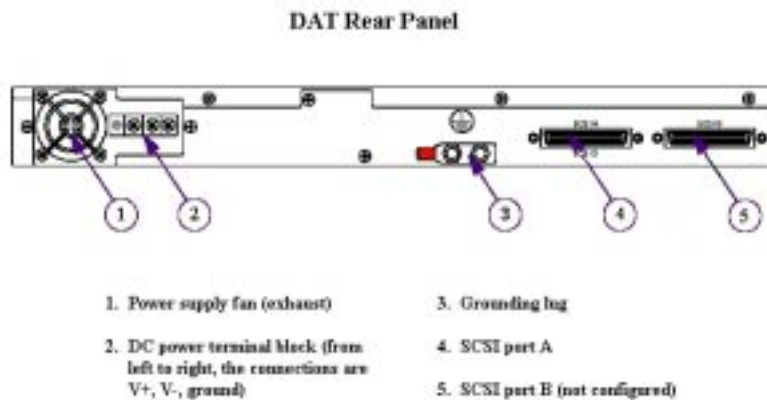

Figure 4.16-1 — NETRA 240 DAT Rear Panel

1. Registered trademark of Sun Microsystems, Inc.

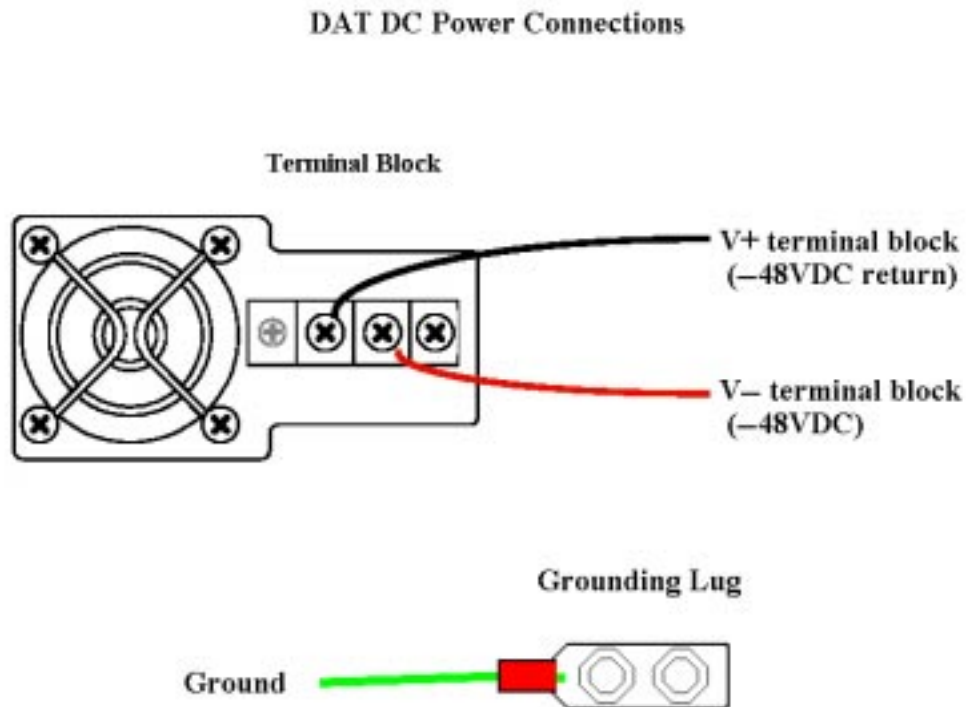

Figure 4.16-2 — NETRA 240 DAT DC Power Connections

- (a) Start by connecting the ground wire to the grounding lug.
 - (b) After the ground wire has been connected to the grounding lug, connect the power cable to the terminal block (positive '+' and negative '-').
2. Restore power to the DAT tape drive unit by closing the circuit breaker for the DC power cable. To close the circuit breaker, insert the fuse by pushing in the fuse while turning it clockwise. The fuse-alarm LED above the fuse will no longer be lit when the fuse is properly seated.
 3. **STOP. YOU HAVE COMPLETED THIS PROCEDURE.**

4.17 Replace a DVD Drive (*Netra*¹ 240)

OVERVIEW

This procedure is used to replace the DVD drive on a *Netra* 240 Administrative Workstation. The DVD drive in the *Netra* 240 is not hot-swappable. The AW must be powered down and the power input cables disconnected before replacing the DVD drive.

Caution: *The DVD drive contains a laser device. If the replacement procedures are not followed, the user risks being exposed to radiation.*

PROCEDURE

1. Halt the AW (see "Halt the Administrative Workstation," Procedure 4.2).
2. Remove power to the AW (see "Remove Power to Administrative Workstation Units (*Netra* 240)", Procedure 4.9).
3. Grip the bezel at the two finger holds and rotate it down to open (see Figure 4.17-1).

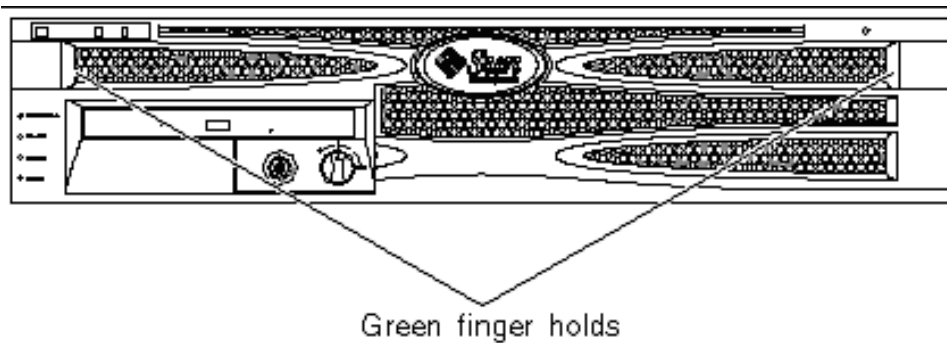

Figure 4.17-1 — NETRA 240 Front Fingerholds

4. Unclip the catches that fasten the DVD drive to the chassis (see Figure 4.17-2).

1. Registered trademark of Sun Microsystems, Inc.

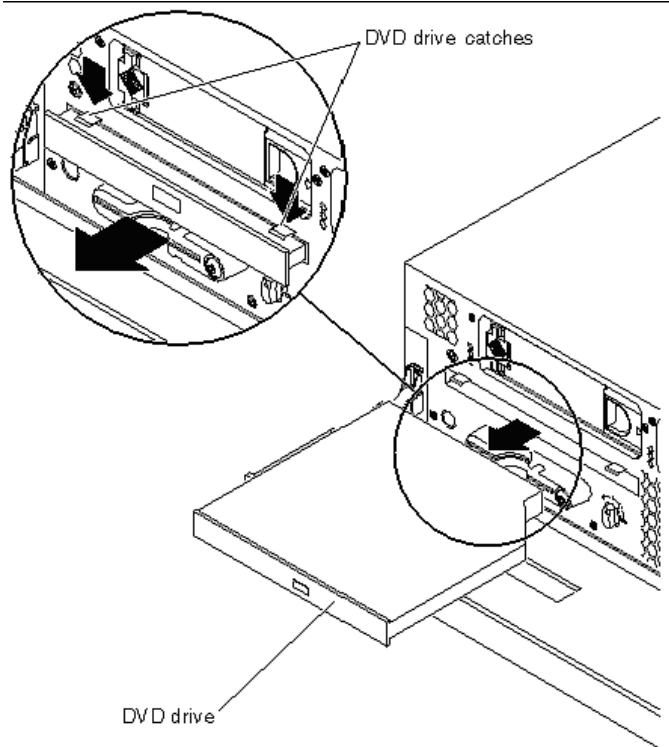

Figure 4.17-2 — NETRA 240 Front Fingerholds

5. Pull the DVD drive toward you until it is free of its connectors and out of the server.
6. Push the replacement DVD drive firmly into the drive slot until the DVD connector is inserted into the system and the clips engage with the chassis (see Figure 4.17-2).
7. Close the bezel until it is locked in place.
8. Restore power to the AW (see “Restore Power to Administrative Workstation Units (*Netra* 240)”, Procedure 4.10).
9. **STOP. YOU HAVE COMPLETED THIS PROCEDURE.**

4.18 Replace a Power Supply Unit (*Netra*¹ 240)

OVERVIEW

This procedure is used to replace a faulty power supply unit in a *Netra* 240 Administrative Workstation (AW). The *Netra* 240 AW has dual redundant power supply units. One power supply can be hot-swapped while the other is still running, without having to power off the AW.

Warning: *Hands and fingers can be pinched while opening and closing the levers on the power supply unit. Keep hands and fingers away from the base and sides of the levers.*

PROCEDURE

1. Locate the faulty power supply unit at the rear of the AW. The power supply units are labeled on the top cover of the AW as PS 0 and PS 1.
2. Disconnect the power input cable from the power supply unit being replaced.
Caution: *Do not remove the power input cable from the remaining power supply unit. Doing so causes the system to go through an immediate ungraceful shutdown.*
3. Pull the lever on the back of the power supply unit down (FIGURE 4.18-1). This disconnects the power supply unit from the power distribution board inside the AW.

1. Registered trademark of Sun Microsystems, Inc.

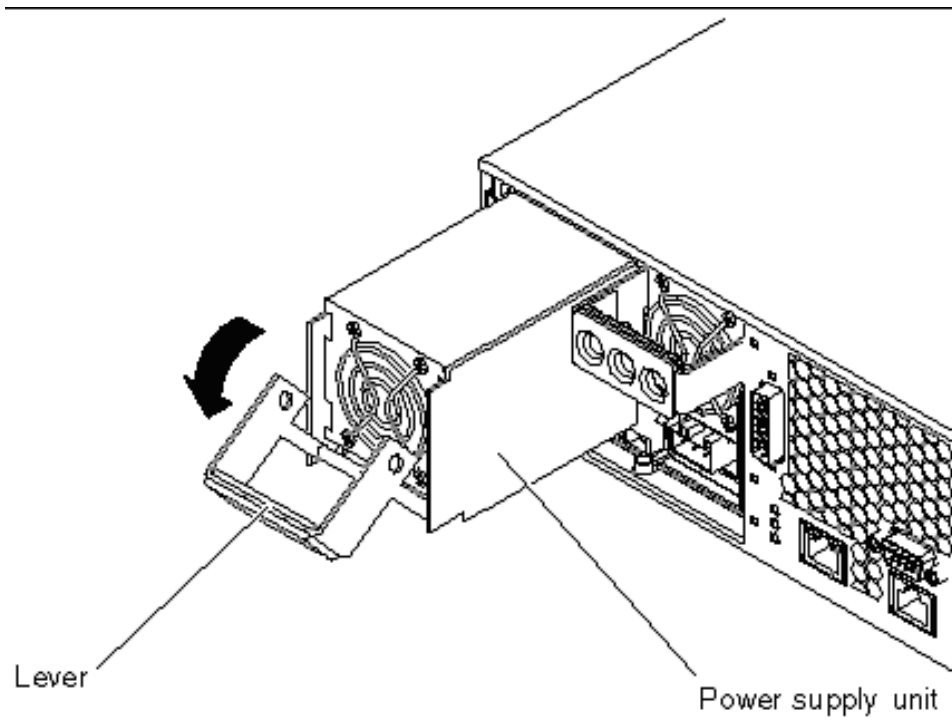

Figure 4.18-1 — Netra 240 Power Supply

4. Slide the power supply unit out of the AW power supply unit bay by pulling on the lever.
5. Insert the replacement power supply unit in the AW power supply unit bay.
6. Slide the power supply unit into the AW until you feel it engages with the power distribution board inside.
7. Ensure that the lever does not return to a vertical position until the power supply unit engages with the power distribution board. If the lever is vertical, the power supply unit does not engage correctly.
8. Press the lever up until it clicks. Returning the lever to a vertical position engages the power supply unit with the power distribution board inside the AW.
9. Connect the power input cable to the power supply unit.
10. The green LED indicator on the back of the power supply unit should light up, indicating that the power supply unit is functioning properly. If the green LED on the back of the power supply unit does not light up, seek technical assistance.
11. **STOP. YOU HAVE COMPLETED THIS PROCEDURE.**

4.19 Load Tape in DAT Tape Drive Unit

OVERVIEW

This procedure contains steps to insert a 4mm tape cartridge into the DAT tape drive unit.

Note: A *Netra*¹ 20 DDS-4 DAT drive can read 90 meter DDS-1 formatted tapes but can not write 90 meter DSS-1 formatted tapes. A *Netra* 240 DAT72 drive cannot read or write 90 meter DDS-1 and 120 meter DDS-2 formatted tapes.

PROCEDURE

1. Verify that the tape cartridge's write-protect switch is set correctly.

For write-protection, the light-colored tab should NOT be visible. For write-enable, the tab should be visible.

2. Check the LEDs on the tape drive front panel to make sure the drive isn't functioning at present.

Both the green and amber LEDs should not be illuminated. It is not recommended to interrupt the tape drive if the green LED is blinking. A steady green LED indicates a data cartridge is in the drive and the drive is ready for activity. There is a problem if the amber LED is blinking.

3. **Netra t 1120** — Insert the tape cartridge so the manufacturer's label is facing *left* and the write enable switch on the cartridge is facing toward you.

Note: On the *Netra t 1120* workstation, to access the tape drive, you must first open the front cover.

Netra 20 — Insert the tape cartridge so the manufacturer's label is facing *right* and the write enable switch on the cartridge is facing toward you.

Netra 240 — Insert the tape cartridge so the manufacturer's label is facing *up* and the write enable switch on the cartridge is facing toward you.

4. Gently push the tape cartridge into the tape drive until the end with the write-enable switch is flush with the tape drive front panel. The tape drive is auto-loading and will pull the tape cartridge the remainder of the way into the drive. DO NOT force the cartridge into the drive. The green LED will blink for a few seconds while the tape is loading then remain steady once the loading process is complete.
5. **STOP. YOU HAVE COMPLETED THIS PROCEDURE.**

1. Trademark of Sun Microsystems, Inc.

4.20 Unload Tape from DAT Tape Drive Unit

OVERVIEW

This procedure contains steps to unload a tape cartridge from the DAT tape drive unit.

PROCEDURE

1. Check the LEDs on the tape drive front panel to make sure you do not abort a tape drive activity.

Caution: Do not press the unload button while the drive is in motion as this will interrupt the drive's ability to accurately store the data. Wait until the green LED is on and not blinking before pressing the unload button.
2. If green LED is blinking, wait for tape to stop.
3. Press the **UNLOAD** button on the front panel of the tape drive and hold it down for at least one full second, or until the green LED starts flashing.
4. Within 90 seconds, the drive rewinds the tape, ejects the cartridge and the green LED will stop flashing and remain off. If the cartridge does not eject after 90 seconds, execute the **Emergency Tape Ejection** procedure. See "Emergency Tape Ejection (*Netra*¹ t 1120, *Netra* 20, *Netra* 240)", Procedure 4.21.
5. **STOP. YOU HAVE COMPLETED THIS PROCEDURE.**

1. Registered trademark of Sun Microsystems, Inc.

4.21 Emergency Tape Ejection (*Netra*¹ t 1120, *Netra* 20 and *Netra* 240)

OVERVIEW

The operating system can apply a *prevent media removal* condition to the tape drive. If this condition is active and the system fails, perform this procedure to remove the DAT tape drive unit and reset the prevent media removal condition.

PROCEDURE

1. Halt the system. See "Halt the Administrative Workstation," Procedure 4.2
2. Remove power to the system or DAT tape drive.
For a *Netra* t 1120 or *Netra* 20 AW, see "Remove Power to Administrative Workstation (*Netra* t 1120 and *Netra* 20), Procedure 4.7.
For a *Netra* 240 AW, see "Remove Power to DAT Tape Drive Unit (*Netra* 240)", Procedure 4.15.
3. Restore power to the system or DAT tape drive.
For a *Netra* t 1120 or *Netra* 20 AW, see "Restore Power to Administrative Workstation (*Netra* t 1120 and *Netra* 20), Procedure 4.8.
For a *Netra* 240 AW, see "Restore Power to DAT Tape Drive Unit (*Netra* 240)", Procedure 4.16.
4. Press the **UNLOAD** button.
5. For a *Netra* t 1120 or *Netra* 20 AW, verify that the emulated AM environment is restored automatically.
6. **STOP. YOU HAVE COMPLETED THIS PROCEDURE.**

1. Trademark of Sun Microsystems, Inc.

4.22 Clean the DAT Tape Drive Unit Head

OVERVIEW

The tape drive head must be cleaned regularly to maintain its reliable operation. Clean the tape drive after every 25 hours of actual tape operation and only with a DDS cleaning cartridge. These cleaning cartridges have the same shape and size as regular media cartridges. No fluids or other preparations are necessary with the use of these cartridges.

Failure to regularly clean the tape drive may result in an accumulation of debris that cannot be removed with the cleaning cartridge. This could result in unreliable read/write operations on the drive.

PROCEDURE

1. Insert the cartridge into the DAT tape drive unit as you would a data tape cartridge.
2. Observe the green LED blinking slowly to indicate that the tape drive is automatically performing the cleaning cycle.

If the cartridge has been used for more than 30 cleaning cycles (depending on the brand), the amber LED will blink rapidly. Press the UNLOAD button to eject the cartridge and discard it.

Note: If the amber LED is flashing at a rate of approximately four flashes per second during the cleaning operation, it indicates the cleaning tape is worn.

3. Remove the cleaning cartridge after it is automatically ejected following the cleaning cycle. The tape drive is immediately available for use.

Caution: *Do not use cleaning cartridges or types of fluids designed for use in audio devices as these can damage the tape drive.*

4. **STOP. YOU HAVE COMPLETED THIS PROCEDURE.**

Distinctive Remote Module (DRM)

CONTENTS		PAGE
5. ROUTINE MAINTENANCE		5 - 1
5.1 Load Software Update(s) from SCANS		5.1-1
5.2 Load Software Update(s) from Tape		5.2-1
5.3 Load Software Update(s) from ASM		5.3-1
5.4 Make Software Update(s) Official		5.4-1
5.5 Install Operating System Software Update		5.5-1
5.6 Backout Last Official Software Update(s)		5.6-1
5.7 Backout Software Update		5.7-1
5.8 Backout Operating System Software Update		5.8-1
5.9 Compact Switch Processor Patch Space		5.9-1
5.10 Activate/Deactivate Balance Feature		5.10-1
5.10.1 Populate Low Level ECD Forms for Log File Retrieval		5.10.1-1
5.10.2 Populate Low Level ECD Forms for TTY Port.		5.10.2-1
5.10.3 Backup Incore ECD to Disk.		5.10.3-1
5.10.4 Activate Balance Feature.		5.10.4-1
5.10.5 Deactivate Balance Feature.		5.10.5-1
5.10.6 Backup Office Dependent Data		5.10.6-1
5.11 Integrate Vendor Stratum 3 Bits Timing Source		5 . 1 1 - 1

LIST OF FIGURES

Figure 5.11-1 — BITS BOX Cabling	5 . 1 1 - 3
Figure 5.11-2 — <i>Telecom Solutions</i> BITS BOX Cabling Connection	5 . 1 1 - 4
Figure 5.11-3 — TSICOM Cabling Connection	5 . 1 1 - 5

LIST OF TABLES

Table 5.10-1 — Activate/Deactivate Balance Feature Activity Selection . . . [5.10-1](#)

5. ROUTINE MAINTENANCE

Overview

Note: Although procedure steps involving software commands can be performed via the ASM (via an OA&M cut-through), someone must be present at the DRM office to perform any hardware portions.

Routine maintenance consists of activities that are performed to maintain a high degree of switch performance. Preventative maintenance is performed on a specified schedule to ensure continuing peak overall performance of the network.

Since peak load periods, features, recent change activities, growth, etc., vary widely in different offices, some tests, such as Routine Exercise (REX), may not have specific test schedules that are best for all offices. In cases of this type, the Equipment Test List (ETL) gives references where procedures, recommendations, and/or guidelines can be found for the listed test(s).

For more information on software updates, backup procedures, and the ETL, see 235-105-210, **5ESS**[®] *Switch Routine Operations and Maintenance Procedures*.

Note: Tape backup of the entire office should be done at least once a month or more often if many software updates are being added to the office. See *Make Full Office Backup Tape*, 235-105-210, *Routine Operations and Maintenance Procedures*.

5.1 Load Software Update(s) from SCANS

OVERVIEW

Note: It is recommended that the host 5E and all subtending DRMs be maintained at the same or within 1 SU/BWM level of each other, with only 2 SU/BWM levels across all nodes. The Host 5E should always be updated first before updating any DRMs.

If the host and subtending DRMs become more than 1 SU/BWM level apart or at least 1 DRM is at a higher SU/BWM level than the host 5E, the following will occur:

1. The application of a new SU/BWM on the 5E will be blocked. If this cannot be corrected by updating the SU level on the DRM(s), the following command can be entered at a 3B21 unix prompt to override the check that blocks the SU application:

touch /etc/NO2LVLCHECK

2. The following output message may be generated on the ROP when accessing Recent Change & Verify (RCV) for a DRM via the ASM:

***REPT ASM VTTY ASM SERVICE rc NOT AVAILABLE, USING AM SERVICE INSTEAD**

This message indicates that layer 1 and 2 RCV crosschecks will be performed locally on the DRM rather than on the ASM. This will result in a slight decrease in RCV throughput but will not block the ability to perform RCV.

Once an SU has been sent to the */etc/bwm* directory using the following procedure, the SU can be applied by using either a cut-through to the Host and each DRM and manually applying the SU from the 1990 MCC page or by using SU Automation (section 2.12.6.2) to automatically apply the SU to the Host and all DRMs in the Switching Complex. The SU Automation method can only be used when an SU is to be installed on the Host and all the DRMs in the complex together. If SU installation on only the Host or a subset of DRMs is desired, then it must be done via a cut-through to each Host/DRM's MCC.

The DRM and host can be in different stages of BWM installation.

Note: This procedure should only be used if `dsdownload` on the ASM is not available! For `dsdownload` procedure refer to the 235-200-145:5ESS[®] *Switch OneLink Manager Administrative Services Module User's Guide*, Chapter "Handling Software Updates."

This procedure can be performed via the ASM or at a DRM site.

In order to load a software update using the Software Change Administration and Notification System (SCANS), a terminal and dial-up modem are needed along with a SCANS login. When the SCANS login is obtained, the SCANS User's Guide and the Training Manual are also provided.

SCANS provides menu driven access to informational bulletins and software updates (SUs). The basic process of loading an overwrite from SCANS is as follows:

- Set up the AW to receive an SU from SCANS.
- Log in to the SCANS system and request the software update.

- Log out from SCANS and wait for the SCANS system to send the SU(s) over the SCANS data link (connected to port 0 on the High Speed Bus Interface [HSI]). This could take up to 24 hours.
- Monitor the status of the SCANS download.
- Verify download is complete.
- Proceed to the “Make Software Update(s) Official,” Procedure 5.4, to apply the SU. Be sure to review the SU and follow any supplied instructions.

Note: Become completely familiar with the SCANS system prior to running this procedure.

There is a 24-hour time limit imposed from the time the switch is primed until SCANS must begin the data session. If SCANS puts the software update load request in the queue, it may take up to that 24-hour limit to start sending data to the switch. **IN REMOTE STARTED** is output to indicate the start of the data session. The **IN REMOTE REPT** message may be output periodically during the session to indicate download progress. Termination of the session is indicated by an **IN REMOTE REPT** output message followed immediately by the **IN REMOTE STOPPED** output message.

PROCEDURE

1. At the MCC, type and enter:

IN:REMOTE:START;

Purpose

Requests that the Administrative Workstation (AW) be put in the remote-file-receive mode. This message should be entered immediately before ordering delivery of software update files from the Software Change Administration and Notification System (SCANS-2), so that the transaction ID displayed in the IN REMOTE output message can be supplied in the order to SCANS-2. Software updates must begin to arrive at the Administrative Workstation within 24 hours. Responsive messages are printed when they are initially received or when this time limit is reached.

Response: IN REMOTE INITIALIZED
TRANSACTION ID: a TIME: b

Where: a = transaction ID to be supplied to SCANS. **This ID value is required in Step 3.**
b = time at which 24-hour timer began in the format hours:minutes.

2. At the SCANS terminal, log in to SCANS per local instructions. Your SCANS password will be required.
3. Using the SCANS menu-driven system, request a load of the software update(s). Refer to the *SCANS User's Guide* and *SCANS Training Manual* supplied with the SCANS login for further detail.
4. SCANS will download the requested SU(s) sometime within the next 24 hours. Monitor the progress of the download using **IN:REMOTE:REPT;**

The possible responses are:

IN REMOTE WAITING

indicates SCANS has yet to download the requested SU(s).

or

```
IN REMOTE                               IN PROGRESS
  FILES RECEIVED: x                       IN PROGRESS
  ELAPSED TIME xx:xx SPACE REMAINING xxxx IN PROGRESS
  INODES REMAINING xxxx
```

indicates the download is in progress.

or

```
IN REMOTE ERROR 12
```

indicates the download completed either successfully or unsuccessfully.

5. Have the following messages printed on the ROP?

```
IN REMOTE STOPPED x
REPT RCVRY SDL 0 COMPLETED
```

If **YES**, continue with Step 6. If **NO**, continue to monitor SCANS using Steps 4 and 5.

Note: SCANS will download the software update (SU) within 24 hours. Users can reenter SCANS to verify downloading has started or to see where the SU is in the queue. If SCANS indicates the SU has been downloaded and the previous messages have not been printed, continue with Step 6.

6. At the MCC, type and enter:

OP:STATUS:LISTDIR, fn="/etc/bwm";

```
total 10
1 drwxrwxrwx      2 root          48      Jan 21 13:56
9 drwxr -xr -x    2 root        4176     Jan 26 09:40
```

Note: The output will contain the contents of the */etc/bwm* directory.

7. The SU number requested should appear on this list.

If **YES**, **STOP. YOU HAVE COMPLETED THIS PROCEDURE.**

If **NO**, seek technical assistance.

5.2 Load Software Update(s) from Tape

OVERVIEW

Note: It is recommended that the host 5E and all subtending DRMs be maintained at the same or within 1 SU/BWM level of each other, with only 2 SU/BWM levels across all nodes. The Host 5E should always be updated first before updating any DRMs.

If the host and subtending DRMs become more than 1 SU/BWM level apart or at least 1 DRM is at a higher SU/BWM level than the host 5E, the following will occur:

1. The application of a new SU/BWM on the 5E will be blocked. If this cannot be corrected by updating the SU level on the DRM(s), the following command can be entered at a 3B21 unix prompt to override the check that blocks the SU application:

touch /etc/NO2LVLCHECK

2. The following output message may be generated on the ROP when accessing Recent Change & Verify (RCV) for a DRM via the ASM:

***REPT ASM VTTY ASM SERVICE rc NOT AVAILABLE, USING AM SERVICE INSTEAD**

This message indicates that layer 1 and 2 RCV crosschecks will be performed locally on the DRM rather than on the ASM. This will result in a slight decrease in RCV throughput but will not block the ability to perform RCV.

Once an SU has been sent to the */etc/bwm* directory using the following procedure, the SU can be applied by using either a cut-through to the Host and each DRM and manually applying the SU from the 1990 MCC page or by using SU Automation (section 2.12.6.2) to automatically apply the SU to the Host and all DRMs in the Switching Complex. The SU Automation method can only be used when an SU is to be installed on the Host and all the DRMs in the complex together. If SU installation on only the Host or a subset of DRMs is desired, then it must be done via a cut-through to each Host/DRM's MCC.

The DRM and host can be in different stages of BWM installation.

Note: This procedure should only be used if dsdownload is not available.

This procedure can be performed via the ASM or at a DRM site.

PROCEDURE

1. Mount the software update tape on tape drive.
Reference: "Load Tape in DAT Tape Drive," Procedure 4.19.
2. At the MCC, type and enter:
COPY:TAPE:IN,TD="/dev/mt00",BSDIR="/etc/bwm";
Response: COPY TAPE IN COMPLETED
3. Unmount software update tape.
Reference: "Unload Tape from DAT Tape Drive," Procedure 4.20.
4. **STOP. YOU HAVE COMPLETED THIS PROCEDURE.**

5.3 Load Software Update(s) from ASM

OVERVIEW

Note: It is recommended that the host 5E and all subtending DRMs be maintained at the same or within 1 SU/BWM level of each other, with only 2 SU/BWM levels across all nodes. The Host 5E should always be updated first before updating any DRMs.

If the host and subtending DRMs become more than 1 SU/BWM level apart or at least 1 DRM is at a higher SU/BWM level than the host 5E, the following will occur:

1. The application of a new SU/BWM on the 5E will be blocked. If this cannot be corrected by updating the SU level on the DRM(s), the following command can be entered at a 3B21 unix prompt to override the check that blocks the SU application:

touch /etc/.NO2LVLCHECK

2. The following output message may be generated on the ROP when accessing Recent Change & Verify (RCV) for a DRM via the ASM:

***REPT ASM VTTY ASM SERVICE rc NOT AVAILABLE, USING AM SERVICE INSTEAD**

This message indicates that layer 1 and 2 RCV crosschecks will be performed locally on the DRM rather than on the ASM. This will result in a slight decrease in RCV throughput but will not block the ability to perform RCV.

Once an SU has been sent to the */etc/bwm* directory using the following procedure, the SU can be applied by using either a cut-through to the Host and each DRM and manually applying the SU from the 1990 MCC page or by using SU Automation (section 2.12.6.2) to automatically apply the SU to the Host and all DRMs in the Switching Complex. The SU Automation method can only be used when an SU is to be installed on the Host and all the DRMs in the complex together. If SU installation on only the Host or a subset of DRMs is desired, then it must be done via a cut-through to each Host/DRM's MCC.

The DRM and host can be in different stages of BWM installation.

PROCEDURE

1. To load software updates on the DRM via the ASM, follow instructions found in 235-200-145, **5ESS[®] Switch OneLink Manager[™] Administrative Service Module User's Guide**, ASM Release 5.0 and Earlier section, *SU Download Via ASM*.

5.4 Make Software Update(s) Official

OVERVIEW

This procedure takes the software update(s) previously loaded into the /etc/bwm from either SCANS or tape, and verifies the files, then applies the software update in "temporary" mode. Next the update enters into a soak period during which time any problems with the update may be discovered. This soak period may last a day or more. Following the soak period, the overwrite is made official and the files are removed from /etc/bwm.

With this procedure, a desired point of installation may be entered. Maintenance personnel can:

1. Step through each stage of an SU Installation one step at a time, or
2. Install an SU through any stage of the installation (including make-official) with just one poke. The SU Installation will stop if an error occurs or if the stop installation poke is entered.

Following is a list of status indicators that will appear during this procedure:

Status	Color	Key Word
not executed	yellow	—
completed	green	COMPLTD
stopped	blue (steady)	STOPPED
aborted	red	ABORTED
in progress	blue (flashing)	INPROGR

PROCEDURE

1. Using the listing of software updates, choose the software update with lowest sequence number.
2. At the MCC Page 1990, type and enter: **9,"yyyyyyyyyy"** to start the software update process.

Where: y . . y = 6-digit or 10-digit software update number, craft (CFT) software update number, or temporary (TMP) software update number.

This will introduce an SU for installation.

Response: The SU name will appear in the page title.

3. At the MCC Page 1990, type and enter: **1** to verify software update and build executable message file.

Response: The verify stage box will change from yellow to a flashing blue and display the word INPROGR. This will continue until the verify aborts or completes. If aborted, the indicator box will change to red and display ABORTED. If the verify successfully completes, the indicator box will change to green and display the word COMPLTD.

4. At the MCC Page 1990, type and enter: **11** to print entire message file.

Response: Message file printed at ROP.

Review message file for events that will take place during activation, or any special actions which must be accomplished manually.

5. At the MCC Page 1990, type and enter: **2** to start the execution of the PREPARE section.
Response: The prepare stage box will change from yellow to a flashing blue and display the word INPROGR. This will continue until the prepare aborts, stops or completes. If aborted, the indicator box will change to red and display ABORTED. If the installation is stopped successfully, the flashing will stop and the indicator box will display the word STOPPED. If, however, the prepare successfully completes, the indicator box will change to green and display the word COMPLTD.
6. To back-out, type and enter: **6**, otherwise, proceed to the next step.
Response: The back-out indicator will flash blue. Once completed, the back-out indicator will appear green and the prepare stage indicator box will revert back to yellow (not executed or initial state).
7. Type and enter: **3** to install through activate.
Response: The stage indicator will change as in the prepare case. Once activate completes, proceed to the next step.
8. To back-out or deactivate at this point, type and enter: **6** or **7**, otherwise, continue to the next step.
Response: The back-out or deactivate indicator will flash blue. Once completed, the corresponding indicator will appear green and the installation stage indicators will revert back to the point indicated by the arrows.
9. At the MCC Page 1990, type and enter: **4** to execute SOAK section of message file.
Response: The stage indicators will change as in the prepare case. Once the soak section completes, and if there is a default soak time, the soak timer will start. This will cause the page to repaint with the 1991 page displayed over the lower portion of the 1990 page. The 1991 page will display the SU soaking, the start and end times, and soak timer options like reset and abort. When the timer completes, the 1991 will disappear and the soak stage indicator will change to green and read COMPLTD.
10. At the MCC Page 1990, type and enter: **5** to start the execution of the OFFICIAL section.
Response: The make official stage indicator box will change from yellow to flashing blue and read INPROGR. Once all the lines in the section successfully complete, the indicator will change to green and read COMPLTD.
If during this step the indicator reads: OFFICIAL STOPPED, perform the following substeps:
 - (a) At the command line, type and enter: **OP:INIT:EMULATOR** to perform an Administrative Workstation (AW) initialization.
Warning: The AW initialization process is NOT service-impacting, however, video terminal and data link access will be unavailable and the switching module will be ISOLATED for about 4 to 5 minutes.

- (b) At the MCC Page 1990, type and enter: **5** to re-start the execution of the OFFICIAL section.
 - (c) At the MCC Page 112, type and enter: **301** and **303** to restore the MHDs.
11. **STOP. YOU HAVE COMPLETED THIS PROCEDURE.**

5.5 Install Operating System Software Update

PROCEDURE

1. Halt the AM emulator (see "Halt the Administrative Module (AM) Emulator," Procedure 4.1).
2. Switch to the *UNIX*¹ console of the AW by holding down the Ctrl key and pressing **Enter** (not Return).
3. If a login prompt does not appear, press **Return** repeatedly until one appears.
4. At the login prompt, login as **awadmin**, for example:
attaws console login: **awadmin**
5. From the Administrative Workstation Main Menu, select "Halt the emulator" and read the information.
6. Enter CARRIAGE RETURN to continue.
7. From the Administrative Workstation Main Menu, select "Install Operating System Software Update."
8. From the Operating System Software Update installation menu, select "Execute installation of an Operating System Software Update." Answer **yes** to the confirmation. If you select a task by mistake, answer **no** to the confirmation.

Response:

You have chosen to install an operating system software update. If the emulator is running, it must be halted before continuing. Refer to the main menu item of **Halt the Emulator**.

Note: If you continue, expect several lines of printout, some of which may say: 'tar: problem reading group entry'. This is normal and should be disregarded.

Do you want to continue? (yes/no) **yes**

9. This task will take approximately 2 minutes. When it is completed, you will be prompted to press Return. When the prompt appears, press **Return**.

The operating system software update installation has completed. At this time the workstation must be rebooted.

10. To view the output of this Operating System Software Update, select "View output from the most recent Operating System Software Update Install." While viewing the output, use the following keys:

space see the next screen of output
b see the previous screen of output
h see a list of available keys
q quit viewing output

11. Select "Return to the main menu."

1. Registered trademark in the United States and other countries, licensed exclusively through X/Open Company, Limited

12. From the Administrative Workstation Main Menu, select "Boot the Workstation." Answer **yes** to the confirmation. If you select a task by mistake, answer **no** to the confirmation.

Response:

You have chosen to boot the workstation. If the emulator is running, it must be halted before continuing. Refer to the main menu item of Halt the Emulator.

Do you want to continue? (yes/no) **yes**

13. The emulated AM environment is restored automatically, verify that this has occurred.
14. If the *UNIX* console page is displayed, switch to the **MCC** of the AW by holding down the Ctrl key and pressing **Enter** (not Return).
15. **STOP. YOU HAVE COMPLETED THIS PROCEDURE.**

5.6 Backout Last Official Software Update(s)

OVERVIEW

This procedure allows up to three software updates previously made official to be backed out. If the update files in /etc/bwm were cleared, it will not be possible to re-apply these overwrites without first replacing the files in /etc/bwm from SCANS or tape.

Warning: *At any point of this procedure, an Administrative Workstation (AW) initialization may be required. If this is necessary, the AW initialization process is NOT service-impacting, however, video terminal and data link access will be unavailable and the switching module will be ISOLATED for about 4 to 5 minutes.*

PROCEDURE

1. At the MCC Page 1950, Program Update Maintenance, type and enter: **9900**

2. After the command is entered, you will be asked to confirm your decision by typing **Y/N**. IN PROGRESS appears if response is **Y**.

Response: IN PROGRESS appears next to 9900 command line.

Note: If the software update contains updates with TARGET=EMULATOR, depending on the update package an initialization may be required to deactivate the update.

3. Access MCC Page **1990**

Response: EXECUTE UPD:INIT:EMULATOR TO DEACTIVATE UPDATE

(a) Using the RESPONSE field on MCC Page 1990, is an initialization of the emulator required?

If **YES**, continue with Step **3b**.

If **NO**, go to Step **4**.

(b) Write AMA data to disk. Type and enter:

WRT: AMADATA;

Response: REPT AMA DISK WRITER FOR STREAM ST1
RECORDING TO DISK SUSPENDED
REPT AMA DISK WRITER FOR STREAM ST1
RECORDING TO DISK RESUMED

(c) Request 3B21 emulator initialization. Type and enter:

UPD:INIT:EMULATOR;

Response: AW completes emulator initialization. MCC displays EAI Page followed the 111 Page.

(d) After initialization completes, return to MCC page 1950.

4. Did command complete successfully and is COMPLETED displayed next to the 9900 command?

If **YES**, continue with the next step.

If **NO**, repeat Step **2**. If command continues to fail, **seek technical assistance**.

- (a) If the software update backout included an emulator update (see Step **3a**), then perform "Backup Administrative Workstation Operating System," Procedure 4.4.
5. If the "new" last official software update needs to be backed out, go to Step **2**.
Note: No more than three official software updates can be removed this way.
6. **STOP. YOU HAVE COMPLETED THIS PROCEDURE.**

5.7 Backout Software Update

OVERVIEW

This procedure can be used to backout software updates which are in the temporary or soaking state.

Warning: *During the execution of the Backout Software Update procedure, an Administrative Workstation (AW) initialization may be required. If this is necessary, the AW initialization process is NOT service-impacting, however, video terminal and data link access will be unavailable and the switching module will be ISOLATED for about 4 to 5 minutes.*

Note: *To backout the last official software update, refer to "Backout Last Official Software Update(s)," Procedure 5.6.*

PROCEDURE

1. Access MCC Page 1990, SU INSTALLATION page.

Is software update number displayed to the right of "SU INSTALLATION OF" the software update that needs to be backed out?

If **YES**, continue with Step 3.

If **NO**, continue to Step 2.

2. At the MCC Page 1990, in order to start the software update process, type and enter:

9,"yyyyyyyyyy"

Where: y . . . y = 6-digit or 10-digit software update number.

Response: On MCC Page 1990, status of software update is displayed in stage box and RESPONSE line.

Message file displayed for next section to be executed.

3. At the MCC Page 1990, type and enter: **6** to backout software update.

Response: EXECUTE ALL COMPLETED: BACKOUT SECTION

Note: If the software update contains an update with TARGET=EMULATOR, depending on the update package, an initialization may be required to deactivate the update.

Response: EXECUTE UPD:INIT:EMULATOR TO DEACTIVATE UPDATE

- (a) Using the RESPONSE field of MCC Page 1990, is an initialization of the emulator required?

If **YES**, continue with Step 3b.

If **NO**, go to Step 4.

- (b) Write AMA data to disk. Type and enter:

WRT: AMADATA;

Response: REPT AMA DISK WRITER FOR STREAM ST1
RECORDING TO DISK SUSPENDED
REPT AMA DISK WRITER FOR STREAM ST1
RECORDING TO DISK RESUMED

- (c) Request 3B21 emulator initialization. Type and enter:**UPD:INIT:EMULATOR;**
Response: AW completes emulator initialization. MCC displays EAI Page followed by the 111 Page.
 - (d) After initialization completes, return to MCC Page 1990.
Did backout complete successfully and “BACK-OUT SECTION COMPLETED” displayed on the RESPONSE line?
If **YES**, continue with Step **3e**.
If **NO**, Repeat Step **3** from the beginning. If step 3 is repeated and the backout does not complete successfully, **seek technical support**.
 - (e) If the software update backout included an emulator update (see Step **3a**), then perform the “Backup Administrative Workstation Operating System,” Procedure 4.4.
4. **STOP. YOU HAVE COMPLETED THIS PROCEDURE.**

5.8 Backout Operating System Software Update

PROCEDURE

1. Halt the AM emulator (see "Halt the Administrative Module [AM] Emulator," Procedure 4.1).
2. Switch to the *UNIX*¹ console of the AW by holding down the Ctrl key and pressing **Enter** (not Return).
3. If a login prompt does not appear, press **Return** repeatedly until one appears.
4. At the login prompt, login as **awadmin**, for example:
attaws console login: **awadmin**
5. From the Administrative Workstation Main Menu, select "Backout Operating System Software Update."
6. From the Operating System Software Update Backout Menu, select "Execute backout of an Operating System Software Update." Answer **yes** to the confirmation. If you select a task by mistake, answer **no** to the confirmation.
Response:
You have chosen to backout the most recent operating System Software Update. If the emulator is running, it must be halted before continuing. Refer to the main menu item of Halt the Emulator.
Do you want to continue? (yes/no) **yes**
7. This task will take approximately 2 minutes. When it is completed, you will be prompted to press Return. When the prompt appears, press **Return**.
The operating system software update backout has completed. At this time the workstation must be rebooted.
8. To view the output of this backout Operating System Software Update, select "View output from the most recent Operating System Software Update Backout." While viewing the output, use the following keys:
space see the next screen of output
b see the previous screen of output
h see a list of available keys
q quit viewing output
9. Select "Return to the main menu."
10. From the Administrative Workstation Main Menu, select "Boot the workstation." Answer **yes** to the confirmation. If you select a task by mistake, answer **no** to the confirmation.
Response:
You have chosen to boot the workstation.If the emulator is running, it must be halted before continuing. Refer to the main menu item of Halt the Emulator.

1. Registered trademark in the United States and other countries, licensed exclusively through X/Open Company, Limited

Do you want to continue? (yes/no) **yes**

11. The emulated AM environment is restored automatically, verify that this has occurred.
12. If the *UNIX* console page is displayed, switch to the MCC of the AW by holding down the Ctrl key and pressing **Enter** (not Return).
13. **STOP. YOU HAVE COMPLETED THIS PROCEDURE.**

5.9 Compact Switch Processor Patch Space

OVERVIEW

The patch space compaction is normally used when the target's switching module patch space becomes insufficient and failed the program update process. The patch space compaction operation will try to increase the size of the target's patch space and make the program update process successful.

Note: If there is a need to backout of patch space compaction after it has been made official, the backout last official (BOLO) process can be used for backout. See "Backout Last Official Software Update(s)," Procedure 5.6.

The target's patch space may become so fragmented or insufficient that even this procedure will be unable to generate sufficient patch space for a successful program update process.

PROCEDURE

1. Enter the following command:

UPD:PATCH:TARGET=a,ACTION=b;

Where: a = SM, SM2K, or CMP
 b = APPLY, OFC, or BKOUT

APPLY = Execute patch space compaction and APPLY on requested target.

OFC = make official for APPLIED target.

BKOUT = Backout previously requested APPLIED target.

The system responds with:

NG = No good.

PF = Printout follows. The ALW:TRFC30 output message will be printed.

INPROG = In progress. The message was accepted and the action is in progress.

CMPL,action = complete action's process. The valid values for action are: APPLY, OFC or BKOUT.

2. **STOP. YOU HAVE COMPLETED THIS PROCEDURE.**

5.10 Activate/Deactivate Balance Feature

OVERVIEW

This procedure activates the ability to provide data for blocked-call identification on analog line units (LU1, LU2, and LU3) in a switching module. The data (high CCS users that cause blocking) is delivered to the Administrative Module (AM) by human machine messages. But to collect the data the balance feature must be activated.

The balance data may be directed to either the TTY port or the 3B21 emulator log files. Activity in the ECD accomplishes this. It is assumed the TTY port has already been defined in the ECD.

Once the ECD is populated, the balance feature is activated, deactivated, and re-activated with Recent Change/Verify (RC/V). The ECD update is a one-time effort.

There are variations in the software release. These differences are noted in the procedure.

PROCEDURE

1. Select the type of activity to be performed from Table 5.10-1.

Table 5.10-1 — Activate/Deactivate Balance Feature Activity Selection

Activity	Go to . . .
First time activation with data directed to 3B21 emulator log file.	Subprocedure 5.10.1
First time activation with data directed to non-balance specific TTY Port.	Subprocedure 5.10.2
Activate balance session	Subprocedure 5.10.4
Deactivate balance session	Subprocedure 5.10.5

5.10.1 Populate Low Level ECD Forms for Log File Retrieval

PROCEDURE

Note: The following low level ECD activity allows the balance output to be redirected to a 3B21 emulator log file.

1. At the MCC terminal, type and enter: **199** to access the Equipment Configuration Database (ECD).
Response: 1. database_name:
2. Type and enter: **incore**
Response: review only:
3. Type and enter: **n**
Response: journaling:
4. Type and enter: *****
Response: Enter Form Name:
5. Type and enter: **trbegin**
Response: tr_name:
6. Enter CARRIAGE RETURN
Response: Enter Execute, Change. . .
7. Type and enter: **e**
Response: Enter Form Name:
8. Type and enter: **classdef**
Response: Enter Database Operation
I=Insert, R=Review, U=Update, D=Delete
9. Type and enter: **u**
Response: class_name
10. Type and enter:
196
Response: Enter Update, Change . . .
11. Type and enter: **c**
Response: Change Field
12. Type and enter: **3**
Response: row
13. Type and enter:
1 (if row 1 value is null or value is being replaced)
or
20 (if additional devices are being added to the current list)
Response: 1) or 20)

14. Type and enter: **balance**
Response: row
15. Type and enter: **<ret>**
Response: Change field
16. Type and enter: **<ret>**
Response: Enter Update, Change . . .
17. Type and enter: **u**
Response: class_name
18. Type and enter: **<**
Response: Enter Form Name:
19. Type and enter: **trend**
Response: tr_name
20. Type and enter: **<ret>** 4 times
Response: Enter Execute, Change. . .
21. Type and enter: **e**
Response: Enter Form Name:
22. Type and enter: **<**
Response: Transaction ended successfully
23. Go to "Backup Incore ECD to Disk," Subprocedure 5.10.3.

5.10.2 Populate Low Level ECD Forms for TTY Port

PROCEDURE

Note: The following low level ECD activity allows the balance output to be directed to an existing TTY port.

1. At the MCC terminal, type and enter: **199** to access the Equipment Configuration Database (ECD).
Response: 1. database_name:
2. Type and enter: **incore**
Response: 2. review only
3. Type and enter: **n**
Response: 3. journaling
4. Type and enter: *****
Response: Enter Form Name:
5. Type and enter: **trbegin**
Response: tr_name
6. Type and enter: **<ret>**
Response: Enter Execute, Change. . .
7. Type and enter: **e**
Response: Enter Form Name:
8. Type and enter: **classdef**
Response: Enter Database Operation
I=Insert, R=Review, U=Update, D=Delete
9. Type and enter: **u**
Response: class_name
10. Type and enter:
196
Response: Enter Update, Change . . .
11. Type and enter: **c**
Response: Change field
12. Type and enter: **3**
Response: row
13. Type and enter:
1 (if row 1 value is null or value is being replaced)
or
20 (if additional devices are being added to the current list)
Response: 1) or 20)
14. Type and enter: (logical device port assignment, for example, rop0)

- Note 1:** To redirect balance output to the ROP, the logical device port assignment would be **rop0**.
- Note 2:** To determine the logical device for other existing TTY ports, refer to 235-600-3XX, *Equipment Configuration Data/System Generation (ECD/SG)*, where XX = the manual number associated with the applicable software release.
- Response: row
15. Enter CARIAGE RETURN
Response: Change field
 16. Type and enter: **<ret>**
Response: Enter Update, Change . . .
 17. Type and enter: **u**
Response: class_name
 18. Type and enter: **<**
Response: Enter Form Name:
 19. Type and enter: **trend**
Response: tr_name
 20. Type and enter: **<ret>** 4 times
Response: Enter Execute, Change. . .
 21. Type and enter: **e**
Response: Enter Form Name:
 22. Type and enter: **<**
Response: Transaction ended successfully
 23. Continue with "Backup Incore ECD to Disk," Subprocedure 5.10.3.

5.10.3 Backup Incore ECD to Disk

PROCEDURE

1. At the MCC terminal, type and enter: **199** to access the ECD.
Response: 1. database_name:
2. Type and enter: **incore**
Response: 2. review only
3. Type and enter: **n**
Response: 3. journaling
4. Type and enter: *****
Response: Enter Form Name:
5. Type and enter: **activate**
Response: 1.copy_inc_to_disk:
6. Enter CARRIAGE RETURN
Response: ODIN requests action desired.
7. Type and enter: **e**
Response: ODIN returns to the DATA ENTRY page.
8. Type and enter: **<**
Response: Transaction ended successfully
9. Continue with "Activate Balance Feature," Subprocedure 5.10.4.

5.10.4 Activate Balance Feature

PROCEDURE

1. Select and prepare terminal for Recent Change and Verify (RC/V) activities using the following steps:
 - (a) At the MCC or STLWS, ensure terminal is in command mode.
 - (b) Is RECENT CHANGE AND VERIFY view displayed?
If **YES**, go to Step **e**.
If **NO**, continue with Step **c**.
 - (c) At the MCC, do Steps **d** through **g**.
 - (d) Type and enter: **196**
Response: RECENT CHANGE AND VERIFY view is displayed with cursor at PRINT OPTION.
 - (e) Type and enter: **n**
Response: Cursor at DETAIL OPTION.
 - (f) Type and enter: **n**
Response: Cursor at VERBOSE OPTION.
 - (g) Type and enter: **y**
Response: RECENT CHANGE AND VERIFY CLASSES page is displayed.
YOU HAVE COMPLETED SELECT AND PREPARE TERMINAL FOR RECENT CHANGE AND VERIFY (RC/V).
2. At the RC/V terminal, type and enter: **8.31U**
Response: OPTIONED FEATURES page displayed. Cursor at FEATURE ID attribute.
3. To activate the balance feature, type and enter the values for each KEY attribute.

```
OPTIONED FEATURES 8.31
*1. FEATURE ID  723
*2. MODULE     OFC
3. ACTIVE      _____
   FEATURE NAME _____
   RELEASE     _____
```

- Response: System completes remainder of view.
Enter Update, Change, Validate, or Print:
4. Type and enter: **c**
Response: Change Field:
 5. Type and enter: **active** or field number 3.
Response: Cursor at ACTIVE attribute.

6. Type and enter: **y**
Response: Change Field:
7. Enter CARRIAGE RETURN
Response: Enter Update, Change, Validate, or Print:
8. Type and enter: **u**
Response: updatingFORM UPDATED
9. Exit Recent Change and Verify.
10. Backup Office Dependent Data using Subprocedure 5.10.6.
11. **STOP. YOU HAVE COMPLETED THIS PROCEDURE.**

5.10.5 Deactivate Balance Feature

PROCEDURE

1. Select and prepare terminal for Recent Change and Verify (RC/V) activities using the following steps:
 - (a) At the MCC or STLWS, ensure terminal is in command mode.
 - (b) Is RECENT CHANGE AND VERIFY view displayed?
If **YES**, go to Step **e**.
If **NO**, continue with Step **c**.
 - (c) At the MCC, do Steps **d** through **g**.
 - (d) Type and enter: **196**
Response: RECENT CHANGE AND VERIFY view is displayed with cursor at PRINT OPTION.
 - (e) Type and enter: **n**
Response: Cursor at DETAIL OPTION.
 - (f) Type and enter: **n**
Response: Cursor at VERBOSE OPTION.
 - (g) Type and enter: **y**
Response: RECENT CHANGE AND VERIFY CLASSES page is displayed.
YOU HAVE COMPLETED SELECT AND PREPARE TERMINAL FOR RECENT CHANGE AND VERIFY (RC/V).
2. At the RC/V terminal, type and enter: **8.31U**
Response: OPTIONED FEATURES page displayed. Cursor at FEATURE ID attribute.
3. To deactivate the balance feature, type and enter the values for each KEY attribute.

```
OPTIONED FEATURES 8.31
*1. FEATURE ID  723
*2. MODULE     OFC
 3. ACTIVE     _____
   FEATURE NAME _____
   RELEASE     _____
```

- Response: System completes remainder of view.
Enter Update, Change, Validate, or Print:
4. Type and enter: **c**
Response: Change Field:
 5. Type and enter: **active** or field number 3.
Response: Cursor at ACTIVE attribute.

6. Type and enter: **n**
Response: Change Field:
7. Enter CARRIAGE RETURN
Response: Enter Update, Change, Validate, or Print:
8. Type and enter: **u**
Response: updatingFORM UPDATED
9. Exit Recent Change and Verify.
10. Backup Office Dependent Data using Subprocedure 5.10.6.
11. **STOP. YOU HAVE COMPLETED THIS PROCEDURE.**

5.10.6 Backup Office Dependent Data

PROCEDURE

1. **Note 1:** Prior to the response, there will be completed responses for the switching module, the AM, and the CMP.

At the MCC, type and enter:

BKUP:ODD,NRODD=xx,RODD,AM,CMP=0;

Where: xx = The switching module number.

Response: BKUP NRODD COMPLETED

Note 2: Database backup will take several minutes to complete.

2. **STOP. YOU HAVE COMPLETED THIS PROCEDURE.**

5.11 Integrate Vendor Stratum 3 Bits Timing Source

OVERVIEW

This procedure performs the following three major activities:

- Verifies that the timing references are connected for the vendor BITS (Building Integrated Timing Supply) clock (referred to later in this procedure as the "BITS box"), with Stratum 3 capability.
- Installs error detection scan points.
- Upgrades the TSICOM circuit pack with UM74D.

For offices configured with an EXM-2000 (Extended Switch Module-2000) refer to 235-105-210, **5ESS**[®] *Switch Routine Operations and Maintenance Procedures*.

- Procedure must be performed at the DRM office.

PROCEDURE

5.11.1 Safe Stop Point

1. Safe Stop Points are provided in the procedure set where progress in the performance of a procedure may be suspended temporarily without causing degradation in the operation of the equipment. Execution of the procedure can be halted at one of these points only if all prior steps within the procedure have been successfully completed.

5.11.2 Prerequisite Conversion Conditions

1. The following prerequisites must be satisfied before performing this procedure.
 - The vendor supplied BITS clock:
*HP55400A*¹ or *Telecom Solutions*² DCD-523 is installed and operational and is supplying a reference signal for the existing switching module.
Note: This procedure is based on the use of a *Telecom Solutions* BITS clock being in place.
 - The following cables must be connected (see Figure 5.11-1):
 - a. Input clock reference cables (2).
 - b. Output clock reference cables (2) to TSIU4/TSIU4-2.
 - c. Scan points wired to the Main Distribution Frame (MDF) for the BITS box.
 - d. Scan point alarm cable (1) from the MDF to the Modular Metallic Service Unit (MMSU).
 - Two UM74D circuit packs must be available.
 - The user must be familiar with Electrostatic Discharge (ESD) protection requirements.

1. HP55400A is a trademark of Hewlett Packard Inc. in the United States and other countries.

2. Telecom Solutions is a registered trademark of Symmetric Com, Inc. in the United States and other countries.

- Customer-supplied Recent Change Verify (RC/V) view for view 8.11 must be available.

5.11.3 PRECONDITIONING

5.11.3.1 Verify and Set Initial Conditions

1. At the MCC, observe Summary Status Area for a SYS NORM indication.
2. If a SYS NORM indication is not obtained, type and enter: **OP:SYSSTAT;**
3. At the MCC, type and enter: **OP:OFFNORM,SM=a;**

Where: a = Switching module number.

Comment: Evaluate system response to determine if system status is acceptable to continue. Specific attention is required for areas that can cause an switching module isolation or service impact during this conversion procedure. Correct any deficiency as required.

Caution: *Steps 4 through 6 are recommended but not required. Local practices should control their use. If routine exercise (REX) is inhibited, it must be allowed at the conclusion of this conversion procedure.*

4. At the MCC, type and enter: **INH:REX,SM=a;**

Where: a = Switching module number.

Response: OK

5. At the MCC, type and enter: **OP:REXINH;**

Response: The inhibit status will be printed. Verify this printout.

6. To backup ODD, at the MCC, type and enter: **BKUP:ODD,NRODD=a,RODD,AM;**

Where: a = Switching module number.

Note: Prior to the response there will be completed responses for the switching module, and the AM.

Response: BKUP NRODD COMPLETED

Note: Database backup will take several minutes to complete.

5.11.3.2 Turn On Fault Recovery Reports

1. At the MCC, either:
type and enter: **SET:PERPH,SM=a,VERBOSE;**
or
type and enter: **412** (1800,a CMD)

Where: a = Switching module number.

Response: OK

5.11.3.3 Save Office Message Class Print Options

1. At the MCC, type and enter: **CHG:LPS,MSGCLS=ALL,TOBKUP;**

Response: OK (with exception)

5.11.3.4 Allow All Message Classes to Print

- At the MCC, type and enter: **CHG:LPS,MSGCLS=ALL,PRINT=ON,LOG=ON;**
Response: OK (with exception)

5.11.3.5 Inhibit Brevity Control

Caution: *Brevity control should not be inhibited for more than ten switching modules, concurrently. This can cause the loss of receive-only printer (ROP) messages.*

- At the MCC, either:
type and enter: **INH:BREVC,SM=a;**
or
type and enter: **609** (1800,a CMD)
Where: a = Switching module number.
Response: OK

5.11.4 SAFE STOP POINT

- This is a **Safe Stop Point**.

5.11.5 VERIFY TIMING REFERENCE CONNECTIONS

- Verify that timing reference cables are installed (see Figure 5.11-1):
 - Input clock reference cables to BITS box.
 - Output clock reference cables between BITS box and TSIU4/TSIU4-2.

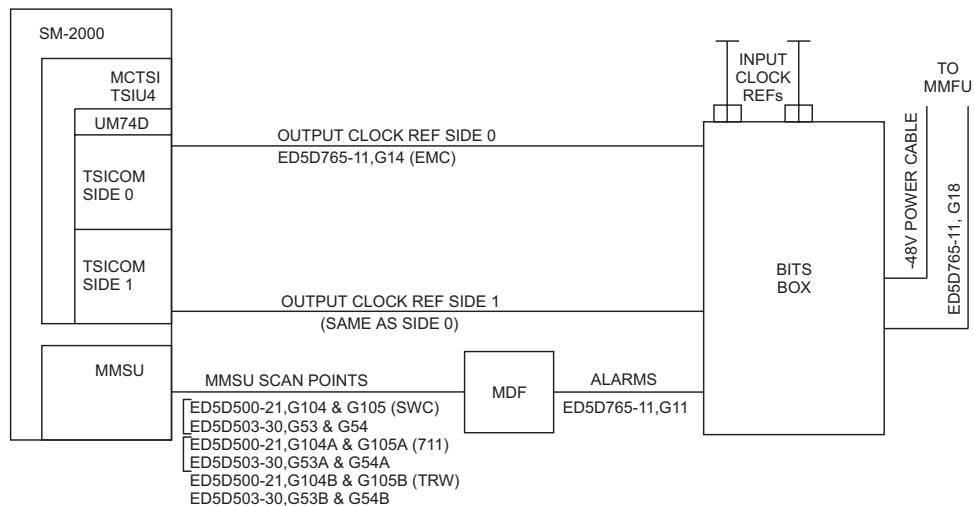

Figure 5.11-1 — BITS BOX Cabling

- At the MCC Page 1190, verify that both Module Controller/Time Slot Interchange (MCTSI) 0 and 1 are ACT/STBY.

5.11.5.1 Verify Timing Reference Connections for MCTSI Side 1

1. With MCTSI-0 active, remove MCTSI-1 from service: type and enter: **201** (1190,a CMD)

Response: RMV MCTSI = a-1 COMPLETED

Where: a = Switching module number.

2. At the MCTSI cabinet, side 1, Power and Control Display (PCD) pack, depress: **OFF** button.

Response: REPT PWR OFF MCTSI = a-1

Where: a = Switching module number.

3. Visually verify connection of output clock reference cable as shown below.

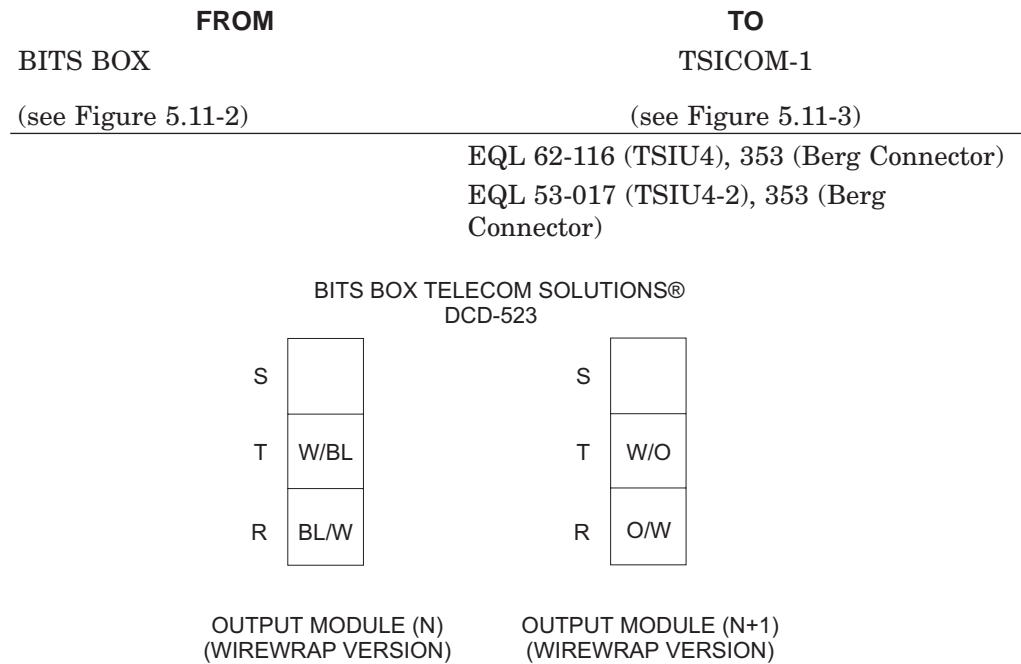

Figure 5.11-2 — Telecom Solutions BITS BOX Cabling Connection

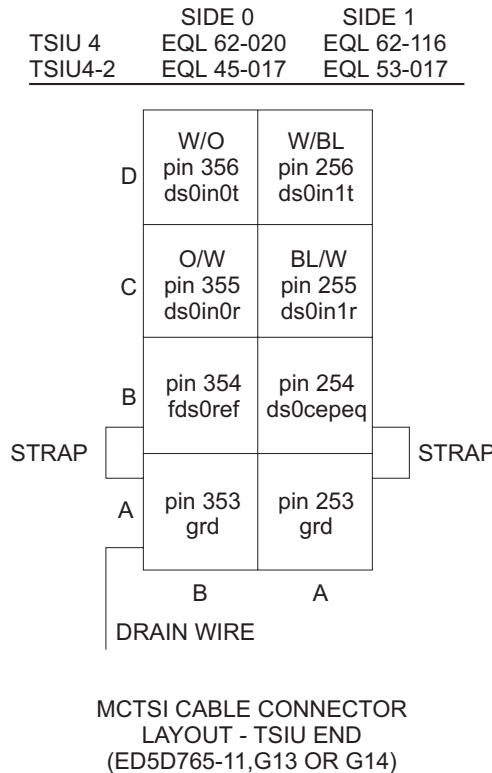

Figure 5.11-3 — TSICOM Cabling Connection

4. Perform BITS Box acceptance tests. Refer to vendor documentation.
5. At the MCTSI cabinet, side 1 PCD pack, depress the **ON** button.
Response: REPT PWR ON MCTSI=a-1
Where: a = Switching module number.
6. At the MCC Page 1190 diagnose MCTSI-1, type and enter: **501**
7. Did MCTSI-1 pass all diagnostics?
If **YES**, continue with Step **8**.
If **NO**, resolve problem, contact next level of technical support as required. Do not continue until problem is resolved.
8. At the MCC Page 1190, are MCTSI-1 external references 0 and 1 in STBY state?
If **YES**, continue with next Subprocedure.
If **NO**, resolve problem, contact next level of technical support as required. Do not continue until problem is resolved.

5.11.5.2 Verify Timing Reference Connections for MCTSI Side 0

1. At the MCC Page 1190 switch MCTSI-1 to active side, enter command **403**.
Response: MCTSI-1 REF 0 and 1 ACTIVE
MCTSI-0 REF 0 and 1 STBY
2. Observe a 15-minute soak period.

- Note:** Should problems occur, contact the next level of technical support and resolve problem. Do not continue until problem is resolved.
3. At the MCC Page 1190, with MCTSI-1 active remove MCTSI-0 from service: type and enter: **200**
 Response: RMV MCTSI = a-0 COMPLETED
 Where: a = Switching module number.
 4. At the MCTSI cabinet, side 0 PCD pack, depress the **OFF** button.
 Response: REPT PWR OFF MCTSI = a-0
 Where: a = Switching module number.
 5. Visually verify connection of output clock reference cable as shown here.

FROM	TO
BITS BOX	TSICOM-0
(see Figure 5.11-2)	(see Figure 5.11-3)
	EQL 62-020 (TSIU4), 353 (Berg Connector)
	EQL 45-017 (TSIU4-2), 353 (Berg Connector)

6. Perform BITS Box acceptance tests. Refer to vendor documentation.
7. At the MCTSI cabinet, side 0 PCD pack, depress the **ON** button.
 Response: REPT PWR ON MCTSI=a-0
 Where: a = Switching module number.
8. At the MCC Page 1190 diagnose MCTSI-0, type and enter: **500**
9. Did MCTSI-0 pass all diagnostics?
 If, **YES**, continue with Step **10**.
 If, **NO**, resolve problem, contact next level of technical support as required. Do not continue until problem is resolved.
10. At the MCC Page 1190, are MCTSI-0 external clock references 0 and 1 in STBY state?
 If, **YES**, continue with Step **11**.
 If, **NO**, resolve problem, contact next level of technical support as required. Do not continue until problem is resolved.
11. Observe a 15-minute soak period.

Note: Should problems occur, contact the next level of technical support and resolve problem. Do not continue until problem is resolved.

5.11.5.3 Install MMSU Scan Points

1. Select customer-supplied RC/V 8.11 forms identifying BITS BOX scan points.
2. From the DCD-523, cross connect terminals (two audible **minor** alarms), connect to an available pair of scan leads from the MMSU. Record scan point used for the minor alarm connection.

3. From the DCD-523, cross connect terminals (two audible **major** alarms), connect to an available pair of scan leads from the MMSU. Record scan point used for the major alarm connection.

4. Select and prepare terminal for RC/V activities.

Note: The identification of the scan points should be known before continuing with the RC/V activity.

5. To provision the first alarm scan point, at the RC/V terminal, type and enter:
8.11i

Response: The REMOTE ALARM ASSIGNMENT page is displayed. The cursor is positioned at the REMOTE MODULE field.

6. To assign alarms, type and enter data for the following fields:

REMOTE MODULE ____

ALARM POINT ____ (000-054, refer to completed 8.11 form for assignment)

SCAN POINT = aaabcddee

Where: aaa = Switching module number
 b = Metallic service unit (MSU) number, 0,1
 c = MSU service group, 0,1
 dd = MSU board number, 00-31
 ee = MSU scan point number, 00-31.

Response: Enter Insert, Change, Validate, or Print:

7. To insert, type and enter:*i*

Response: inserting . . . FORM INSERTED.

8. Repeat Steps **6** and **7** to insert additional scan point.

9. With all scan points assigned, exit RC/V.

10. To backup ODD, at the MCC, type and enter:

BKUP:ODD,NRODD=a,RODD,AM;

Where: a = Switching module number.

Note: Prior to the response, there will be completed responses for the switching module and the AM.

Response: BKUP NRODD COMPLETED

Note: Database backup will take several minutes to complete.

5.11.5.4 Test BITS Box Alarms

1. Disconnect one of the input clocks from the BITS box.

Response: A MINOR alarm output message is generated.
MINOR alarm LED on the BITS Box SAI/MTS card is lighted.

2. Reconnect the clock input that was disconnected in the previous Step.

3. At the BITS Box press the ACO switch on the SAI/MTS card to clear the MINOR alarm.

Response: MINOR alarm LED on the BITS box SAI/MTS card is off.

4. **Warning:** *An antistatic wrist strap must be worn while handling circuit packs or system cables to prevent damage to components by static electricity.*

At the BITS Box temporarily remove the active CI card.

Response: A MAJOR alarm output message is generated.
MAJOR alarm LED on the BITS box SAI/MTS card is lighted.

5. Re-install the **CI** card and press the **ACO** switch on the **SAI/MTS** card to clear the MAJOR alarm.

Response: MAJOR alarm LED on the BITS box SAI/MTS card is off.

5.11.6 UPGRADE TSICOM PACK

5.11.6.1 Remove MCTSI 0 From Service

1. With MCTSI-1 active, remove (MCTSI) side 0 from service. At the MCC, either:
type and enter: **RMV:MCTSI=a-0**;
or
type and enter: **200** (1190,a CMD)

Where: a = Switching module number.

Response: RMV MCTSI=a-0 COMPLETED

5.11.6.2 Update TSICOM 0 CLI

1. Select and prepare terminal for RC/V activities.
2. At the RC/V terminal, type and enter: **18.1U**
Response: SWITCHING MODULE (RC_EQIM) 18V1 page displayed.
Cursor at SM attribute.
3. Type and enter switching module number.
Response: System populates remainder of view.
Enter Update, Change, Validate, or Print:
4. Type and enter: **c**
Response: Change field:
5. Type and enter: **TSICOM 0 CLI** or field number.
Response: Cursor at TSICOM 0 CLI attribute.
6. Type and enter the appropriate hex value:

DESCRIPTION	HEX VALUE
TSIU4 with external clock reference	23
TSIU4-2 with external clock eference	33

Response: Change field:

7. Enter CARRIAGE RETURN
Response: Enter Update, Change, Validate, or Print:

8. Type and enter: **u**
Response: updating...FORM UPDATED
SWITCHING MODULE (RC_EQIM) 18V1 page displayed.
Cursor at SM attribute.
9. Type and enter: **<**
Response: 18.0 SM & REMOTE TERMINALS VIEWS page displayed.
10. Type and enter **q**
Response: RCV-196 COMPLETED

5.11.6.3 Power Down MCTSI Side 0 And Replace Circuit Pack

1. At the MCTSI cabinet, side 0 PCD pack, depress the **OFF** button.
Response: REPT PWR OFF MCTSI=a-0
Where: a = Switching module number.
2. **Warning: An antistatic wrist strap must be worn while handling circuit packs or system cables to prevent damage to components by static electricity.**

Remove the UM74B/UM74C circuit pack from MCTSI side 0 (per EQL) and replace with UM74D.

EQL 62-020	TSIU4
EQL 45-017	TSIU4-2

5.11.6.4 Power Up MCTSI Side 0

1. At the MCTSI cabinet, Side 0 PCD pack, depress the **ON** button.
Response: REPT PWR ON MCTSI=a-0
Where: a = Switching module number.

5.11.6.5 Diagnose MCTSI Side 0

1. At the MCC, either:
type and enter: **DGN:MCTSI=a-0,PH=33,RAW,TLP;**
or
type and enter: **500,PH=33** (1190,a CMD)
Where: a = Switching module number.
Response: DGN MCTSI=a-0 COMPLETED ATP

5.11.6.6 Unconditionally Restore MCTSI Side 0

1. At the MCC, either:
type and enter: **RST:MCTSI=a-0,UCL;**
or
type and enter: **300,UCL** (1190,a CMD)

Where: a = Switching module number.
Response: RST MCTSI=a-0 COMPLETED

5.11.6.7 Remove MCTSI 1 From Service

1. Switch MCTSI-0 to active side, enter input command **403**
2. With MCTSI-0 active, remove (MCTSI) Side 1 from service. At the MCC, either:
type and enter: **RMV:MCTSI=a-1;**
or
type and enter: **201** (1190,a CMD)

Where: a = Switching module number.
Response: RMV MCTSI=a-1 COMPLETED

5.11.6.8 Update TSICOM 1 CLI

1. Select and prepare terminal for RC/V activities.
2. At the RC/V terminal, type and enter: **18.1U**
Response: SWITCHING MODULE (RC_EQIM) 18V1 page displayed.
Cursor at SM attribute.
3. Type and enter switching module number.
Response: System populates remainder of view.
Enter Update, Change, Validate, or Print:
4. Type and enter: **c**
Response: Change field:
5. Type and enter: **TSICOM 1 CLI** or field number.
Response: Cursor at TSICOM 1 CLI attribute.
6. Type and enter the appropriate hex value:

DESCRIPTION	HEX VALUE
TSIU4 with external clock reference	23
TSIU4-2 with external clock eference	33

Response: Change field:

7. Enter CARRIAGE RETURN
Response: Enter Update, Change, Validate, or Print:
8. Type and enter: **u**
Response: updating...FORM UPDATED
SWITCHING MODULE (RC_EQIM) 18V1 page displayed.
Cursor at SM attribute.
9. Type and enter: **<**
Response: 18.0 SM & REMOTE TERMINALS VIEWS page displayed.

10. Type and enter: **q**

Response: RCV-196 COMPLETED

5.11.6.9 Power Down MCTSI Side 1 And Replace Circuit Pack

1. At the MCTSI cabinet, side 1 PCD pack, depress the **OFF** button.

Response: REPT PWR OFF MCTSI=a-1

Where: a = Switching module number.

2. **Warning: An antistatic wrist strap must be worn while handling circuit packs or system cables to prevent damage to components by static electricity.**

Remove the UM74B/UM74C circuit pack from MCTSI side 1 (per EQL) and replace with UM74D.

EQL 62-116	TSIU4
EQL 53-017	TSIU4-2

5.11.6.10 Power Up MCTSI Side 1

1. At the MCTSI cabinet, side 1 PCD pack, depress the **ON** button.

Response: REPT PWR ON MCTSI=a-1

Where: a = Switching module number.

5.11.6.11 Diagnose MCTSI Side 1

1. At the MCC, either:
type and enter: **DGN:MCTSI=a-1,PH=33,RAW,TLP;**
or
type and enter: **501,PH=33** (1190,a CMD)

Where: a = Switching module number.

Response: DGN MCTSI=a-1 COMPLETED ATP

5.11.6.12 Unconditionally Restore MCTSI Side 1

1. At the MCC, either:
type and enter: **RST:MCTSI=a-1,UCL;**
or
type and enter: **301,UCL** (1190,a CMD)

Where: a = Switching module number.

Response: RST MCTSI=a-1 COMPLETED

5.11.7 SAFE STOP POINT

1. This is a **Safe Stop Point**.

5.11.8 RESTORE CONTROLS

5.11.8.1 Allow Brevity Control

1. At the MCC, either:
type and enter: **ALW:BREVC,SM=a;**
or
type and enter: **709** (1800,a CMD)
Where: a = Switching module number.
Response: OK

5.11.8.2 Return Message Classes to Previous Print Status

1. At the MCC, type and enter:
CHG:LPS,MSGCLS=ALL,FROMBKUP;
Response: OK

5.11.8.3 Turn Off Fault Recovery Reports

1. At the MCC, either:
type and enter: **CLR:PERPH,SM=a,VERBOSE;**
or
type and enter: **512** (1800,a CMD)
Where: a = Switching module number.
Response: OK

5.11.8.4 Allow Routine Exercises

Caution: *All routine exercises inhibited earlier in the procedure must be allowed. Failure to do this may result in office degradation over time.*

1. At the MCC, type and enter:
ALW:DMQ,SRC=REX;
Response: ALW DMQ ENABLED REX
2. At the MCC, either:
type and enter: **ALW:REX,SM=a;**
or
type and enter: **702** (1800,a CMD)
Where: a = Switching module number.
Response: OK

5.11.8.5 BackUp Office Dependent Data

1. At the MCC, type and enter:
BKUP:ODD,NRODD=a,RODD,AM;
Where: a = Switching module number.

Note: Prior to the response, there will be completed responses for the switching module, and the AM.

Response: BKUP NRODD COMPLETED

Note: Database backup will take several minutes to complete.

5.11.8.6 Reschedule Automatic Office Dependent Data Backup, If Necessary

1. At the MCC, type and enter: **BKUP:ODD,EVERY=c,AT=d;**

Where: c = Interval in days (0-90) between successive ODD backup runs
d = Time of day in hours and minutes (0-2359).

Response: OK

5.11.8.7 Recommended Soak Period

1. Monitor the ROP output for any peripheral fault recovery error messages. If any such messages occur within a period of 30 minutes take appropriate action to determine the reason; and, correct the reported error(s), if necessary, before continuing.
2. **STOP. YOU HAVE COMPLETED THIS PROCEDURE.**

Distinctive Remote Module (DRM)

CONTENTS		PAGE
6. CORRECTIVE MAINTENANCE		6 - 1
6.1 Respond to and Restore a Locked-Up Video Terminal		6.1-1
6.2 Perform Office Terminal Software Initialization		6.2-1
6.3 Remove and Insert Line Unit (LU) Circuit Packs.		6.3-1
6.4 Invoke the Automatic Circuit Pack Return Tag Tool		6.4-1
6.5 Analyze and Clear Non-Diagnosable Switching Module Memory Errors.		6.5-1
6.6 Replace EI Paddle Board.		6.6-1
6.7 Replace CPI Paddle Board		6.7-1

LIST OF FIGURES

Figure 6.6-1 — <i>Ethernet</i> Interface Paddle Board	6.6-1
Figure 6.6-2 — SM-2000 DIP Switch Settings	6.6-2
Figure 6.7-1 — CPI Paddle Board	6.7-1

LIST OF TABLES

Table 6.6-1 — Switching Module DIP Switch Settings.	6.6-3
---	-------

6. CORRECTIVE MAINTENANCE

Overview

Note: Although procedure steps involving software commands can be performed via the ASM (via an OA&M cut-through), someone must be present at the DRM office to perform any hardware portions.

Corrective maintenance procedures are only performed when a fault condition warrants intervention to restore Switching Complex equipment to proper operation.

Before performing any maintenance procedure, become familiar with the procedure steps and pay particular attention to any **Notes**, **Cautions**, or **Dangers** that accompany a maintenance operation.

When handling circuit packs, **ALWAYS** observe the following cautions:

Caution 1: *Handle circuit packs by their edges or face plate to avoid deforming components and leads or scratching the gold plated connector contacts. Contact damage or contamination can cause poor connections.*

Caution 2: *Before removing or inserting a circuit pack, power down the circuit, unless otherwise specifically directed in a maintenance procedure.*

Caution 3: *When changing circuit packs in an attempt to locate a trouble, always restore a pack to its original location if the replacement pack does not clear the trouble. This will aid in isolating the trouble by returning the circuit to its original configuration which existed at the time the failure was first detected.*

Caution 4: *When handling circuit packs, always use care to avoid static discharges. Circuit packs should remain in the antistatic shipping container or in some other antistatic container until they are to be inserted. When inserting or removing circuit packs, personnel should be properly grounded, using a wrist strap connected to a frame ground or a designated ground connect point.*

6.1 Respond to and Restore a Locked-Up Video Terminal

OVERVIEW

This procedure restores a video terminal at a DRM site that is not responding to keystrokes. For this procedure, personnel need a good understanding of terminal configurations and should know how to use the MCC video terminal to locate the display page(s) that can be helpful in restoring the locked-up video terminal.

For *Sun*¹ and MCC console terminal settings, see “*Sun* Console/Master Control Center (MCC) Terminal Settings,” Appendix A1.

PROCEDURE

1. Determine if this is the only terminal not responding to keystrokes.
If this is the only terminal that is locked-up, go to step 4.
If all terminals are failing to respond, continue with step 2.
2. Can the EAI page be displayed on the MCC terminal?
If all terminals are locked-up but the EAI page can be displayed on the MCC, go to step 8.
If all terminals including the MCC are locked-up, continue with step 3.
3. Verify the MCC terminal option settings (see “*Sun* Console/Master Control Center (MCC) Terminal Settings,” Appendix A1).
4. Identify the locked up terminal’s Teletypewriter (TTY) member number. In this procedure the TTY member number and the video terminal number are synonymous. The video terminal number is probably at the top of the status indicator on the MCC or the STLWS.
5. Locate another operational video terminal that is assigned to the same switch as the locked-up video terminal.
6. At the operational video terminal, enter either (a) or (b) to restore the faulty video terminal to service. If the terminal to be restored is the MCC, enter (b), otherwise enter (a).
 - (a) **RST:TTY=a[,UCL];**
 - (b) **RST:MTTY=a[,UCL];**Where: a = TTY member number (0-255).
Response: A **PF** entry (on the same line as the input message), followed by a **RST TTY** output message.
7. Does the **RST TTY** output message and video terminal being restored indicate restoration? (For example, the **RST TTY** output message contains the TTY member number (0-255), followed by **COMPLETED**.) The restored video terminal should display a **CFTSHL TERMINAL IN SERVICE** message.
If these two conditions do not exist, go to Step 5.
If these two conditions do exist, **STOP. YOU HAVE COMPLETED THIS PROCEDURE.**

1. Trademark of Sun Microsystems, Inc.

Note: Step **5** is performed **ONLY** when the **RST** input messages (**RST:TTY** and **RST:TTYC**) fail to restore the locked-up terminal. To perform Step **8**, the video terminal at the MCC must be operational.

8. Go to "Perform Office Terminal Software Initialization," Procedure 6.2.

6.2 Perform Office Terminal Software Initialization

OVERVIEW

Initialize office terminal software at a DRM site.

Warning: *Performing the following procedure will disable the terminal equipment until initialization is completed.*

PROCEDURE

1. At Master Control Center (MCC) video terminal, is the **EMERGENCY ACTION INTERFACE (EAI) PAGE** displayed?

If **YES**, proceed to Step 3

If **NO**, continue with next step.

2. At MCC video terminal, depress **EA DISP** key to display **EMERGENCY ACTION PAGE**

Response: **EMERGENCY ACTION PAGE** is displayed.

3. On the EAI PAGE, type and enter: **42; n; 15;**

Where: n = The level of craft initialization 1, 2, or 3 (start with level 1 and escalate to level 3).

- | | |
|----------|--|
| 1 | Craft initialization level 1 terminates and restarts all craft processes and also restarts MTTY controllers. |
| 2 | Craft initialization level 2 terminates and restarts all killable nonessential user and supervisor processes and also restarts all MTTY and TTY controllers. |
| 3 | Craft initialization level 3 terminates and restarts all killable essential and non-essential user and supervisor processes. |

Response: craft initialize? (y/n)

4. Type and enter: **y**.

Response: **PRM vBda 7400 xxyy zzzz hh hh hh** printed on ROP.

Where: v = E or F.
xx = craft initialization level (0103o 03)
yy = craft initialization phase (0104o 04)
zzzz = 0000=current phase proceeds normally
0001=phase timed out
0002=craft initialization aborted
0003=craft initialization failed
0004=craft initialization completed successfully

Note: **PRM EBda 7500 0000 0000 hh hh hh** indicates that craft initialization was denied because another craft initialization is already in progress.

5. Is craft terminal initialization successful?

If **YES**, **STOP. YOU HAVE COMPLETED THIS PROCEDURE.**

If **NO**, continue with next step.

6. Was APPLICATION PARAMETER = 3?
If **YES**, continue with next step.
If **NO**, increase APPLICATION PARAMETER by one and repeat from Step **3**.
7. On the EAI PAGE, type and enter: **43**
8. Type and enter: **15** to perform Craft Terminal Initialization.
9. **STOP. YOU HAVE COMPLETED THIS PROCEDURE.**

6.3 Remove and Insert Line Unit (LU) Circuit Packs

OVERVIEW

This procedure provides the proper sequence(s) for removal (or unseating) and insertion (or reseating) of Line Unit (LU) circuit packs. Unseating of all grid and Gated Diode Crosspoints Access (GDXACC) packs is required before -48 V DC is restored if the LU is not equipped for Line Unit Auto Power Recovery (LUARP). Unseating and reseating in the proper sequence(s) is/are required to avoid potential damage to certain packs that can occur when other packs are missing or not powered up. For this reason, the following **Cautions** should be observed. Also, for personal safety, observe the following **DANGER**.

Caution 1: *Do not remove any -48 V DC fuse at the LU cabinet or at the Power Distribution Frame (PDF) or in any other way interrupt the -48VDC power to the LU packs as a troubleshooting technique.*

Caution 2: *Removal of an entire LU from service should only be done when necessary (rarely). Once power is lost, the system may remove working lines, marking them "OOS, MAN." These lines must be restored via Step 9 to complete this procedure and minimize the interruption of service on those lines connected to the LU.*

Danger: *Hazardous voltages are present on LU packs (even shortly after they are removed from the cabinet). Do not touch exposed components or wiring paths on the pack. When removing or inserting a pack, use the latch and hold the pack at its edges without touching components or paths.*

PROCEDURE

1. For LU Model 3 (J5D004AD):
 - a. For the entire LU, perform Step 3.
 - b. For a TN832(B) pack only, remove the GDXACC circuit in the SG from service with the appropriate **RMV** input messages and unseat the TN831(B) (first) and then the TN832(B) pack.
 - c. **STOP. YOU HAVE COMPLETED THE PACK REMOVAL PORTION OF THIS PROCEDURE.**
2. For insertion or reseating of LU packs:
 - a. For LU Model 3 (J5D004AD):
 1. For the entire LU, perform Step 3.
 2. For a TN832(B) pack only, insert and latch the TN832(B) pack and (last) the TN831(B) pack. Unconditionally restore the packs with the appropriate **RST** input messages.
 3. **STOP. YOU HAVE COMPLETED THIS PROCEDURE.**
3. Before removing/unseating any LU packs, verify that the LU's equipment groups (Service Group SG 0 and SG 1) and GRIDs (0-7/9) are out of service (OOS). Use of the appropriate **RMV** input messages with the unconditional (UCL) option may be required to remove the entire LU from service.

4. Use the appropriate pack removal/unseat procedure as follows:
 - a. Circuit Pack Removal Sequence for LU Model 3 (J5D004AD):
 1. For each equipped GRID (GRID 0 - GRID 9), unseat the two GRID packs [TN838s, TN1048s, TN1058(B,C)s].
 2. For each equipment group (SG 0 and SG 1), unseat the TN831(B) (first) and the TN832(B) (last).

5. **STOP. YOU HAVE COMPLETED THE PACK REMOVAL PORTION OF THIS PROCEDURE.**

6. Before inserting or reseating the packs in the LU, verify that no fuses are blown for the -48 V DC power to the LU (either at the LU cabinet or at the Power Distribution Frame (PDF)).

Note: In Step 7, when inserting the packs (one at a time), be alert to a fuse blowing at the LU cabinet or at the PDF. The blowing of the fuse may be due to a faulty pack being inserted or some other trouble causing excessive current load that should be cleared before proceeding with the pack insertion procedure.

7. Use the appropriate pack inserting/reseating procedure as follows (be alert for the blowing of a fuse):
 - a. Circuit Pack Insertion Sequence for LU Model 3 (J5D004AD):
 1. Insert and latch (one at a time, in the order specified) the UN322(B), TN335(C,E)s, TN844s, TN832(B), and (last) the TN831(B).
 2. For each equipped GRID (GRID 0 - GRID 9), insert and latch (one at a time) the GRID packs [TN838s, TN1048s, TN1058(B,C)s].
8. Unconditionally restore both SGs and all GRIDs of the LU to service, using the appropriate **RESTORE** commands at the Master Control Center (MCC) display pages or via the appropriate **RST** input messages.
9. List the OOS lines, type and enter:
OP:LIST,LINES,FULL:OOS.
Type and enter: **RST:LINE** to restore the OOS lines. Sample test for dial tone.
10. **STOP. YOU HAVE COMPLETED THIS PROCEDURE.**

6.4 Invoke the Automatic Circuit Pack Return Tag Tool

OVERVIEW

The automatic circuit pack Return Tag (RTAG) tool allows maintenance personnel to display and print recent diagnostic and fabric test faults, as well as generate (in an interactive fashion) circuit pack return tags to be used in returning faulty circuit packs to the Lucent Technologies factory for repair. The following shows the basic menu of the tool.

PROCEDURE

1. The return tag tool can be invoked by any of the following methods:
 - (a) At an ASM workstation, cut-through to the Control Display Page, type and enter: **194**, then select **RTAG**.
 - (b) At the *UNIX*¹ terminal, type and enter: **/usr/bin/rtag**
 - (c) At the *STLWS* terminal, type and enter: **RCV:MENU:RTAG**;
 - (d) At the MCC Page 194, select **RTAG**

The following interface menu is first printed:

```
Depress PF3 key twice to reconnect to the SCREEN process if
the Command Message Key (PF3) has been used during this procedure.
```

```
What is the desired command?
```

```
o) ODBE      c) CNIDBOC
a) ACCED    r) RTAG
u) UNIX SHELL  Q) TO QUIT
```

```
Please enter o,a,u,c, r, or Q:
```

```
Character mappings
\:, \1, \s, \0, -, \a, \/, \\\, \
;, !, $, &, -, @, ?, \,
```

Note: When RTAG is invoked from the MCC, the screen will not be drawn exactly like those shown on the following pages. This is due to the unique display capabilities of the MCC. The screens shown will scroll on the MCC rather than be redrawn. This may cause some confusion when entering selections. For this reason it is strongly recommended that this tool be invoked from an *STLWS*, if available.

2. After the RTAG tool is invoked, the following interface header is printed:

```
WELCOME TO THE AUTOMATED CIRCUIT PACK RETURN TAG TOOL
```

1. Registered trademark in the United States and other countries, licensed exclusively through X/Open Company, Limited

If running RTAG from the MCC and not an STLWS, press **RETURN**. The following menu is displayed:

```
Please select one of the following commands:  
(1) Select diagnostic failure(s) by circuit identifier  
(2) Select diagnostic failure(s) by circuit identifier and number  
(3) Select diagnostic failure(s) by date  
(4) Select diagnostic failure(s) by number of last fault(s)  
(5) Select diagnostic failure(s) by all faults  
(6) Generate a circuit pack return tag for update  
(7) Empty the fault database and/or change password  
  
(! to go back, h for Help, q to quit)
```

(a) For selection **1**, the following display is shown:

```
Please enter the circuit identifier  
(e.g., MCTSI, MASC):  
(! to go back, h for Help, q to quit)
```

(b) Go to Step **3**.

(c) For selection **2**, the following display is shown:

```
Please enter the circuit identifier and number  
(e.g., MCTSI=15-1, CU=0 MASC=2):  
(! to go back, h for Help, q to quit)
```

(d) Go to Step **3**.

(e) For selection **3**, the following display is shown:

```
Please enter the date  
(Format mm-dd-y):  
(! to go back, h for Help, q to quit)
```

(f) Go to Step **3**.

(g) For selection **4**, the following display is shown:

```
Please enter the number of last faults to review  
(Valid number is 1 - n):  
(! to go back, h for Help, q to quit)
```

Where: n = Number of existing fault entries in the circular database.

Go to Step **3**.

(h) For selection **5**, the menu in Step **3** is displayed

Go to Step **3**.

(i) For selection **6**, the five questions in Step **4b** are asked, then an update tag is printed on the Receive-Only Printer (ROP). The menu is redisplayed.

(j) For selection **7**, if there is no password (initially), the following will be displayed.

Note: This initial condition indicates when the software release is first retrofitted or the database file is removed by **rm** command from a *UNIX* system terminal.

Otherwise, the following will be displayed:

```
There is no password.  
Please enter a password  
(NOTE: The length of the password cannot exceed 6 characters)  
(! to go back, h for Help, q to quit)  
Enter the password again:
```

```
Please enter the password
```

If the password does not match, the access of this command to empty the database is denied, and the main menu is redisplayed. If the password matches, then the following will be displayed:

```
Do you want to flush the fault database?  
Please enter y for yes, or n for no, or q to quit  
default is no  
(! to go back, h for Help, q to quit)
```

If the answer is **y**, the fault database is flushed. Then, the following will be displayed:

```
Do you want to change the password?  
Please enter y for yes, or n for no, or q to quit:
```

If the answer is **y**, the following will be displayed:

```
Please enter the new password:  
Enter the new password again:
```

and go back to main menu.

3. The following menu is displayed:

```
Please select one of the following commands:  
(1) Print the summary of the fault entries on ROP  
(2) Display the summary of the fault entries  
  
(! to go back, h for Help, q to quit)
```

- (a) For selection **1**, the summary of the fault entries that satisfy the selection is first dumped into a temporary file. Then the file is printed at the ROP. The menu is redisplayed.
- (b) For selection **2**, the fault entries are displayed as follows:

```
The following shows the fault entries that satisfy
the selected key (YYY):
(1) M 04-10-94 12:50 PSUPH=8-0-1-7 STF PH 1 SEG 2 TEST 19 MM H'fa72
(2) A 03-12-94 01:05 MCTSI=10-0 STF PH 4 SEG 1050 TEST 1 MM H'2
.
.
(10) M 10-15-94 03:45 MCTSI=10-0 STF PH 4 SEG 1050 TEST 1 MM H'2
To display a tag, enter the fault number.
To page down the fault list, hit the <ENTER> key.
To page up the fault list, enter u.
To print the current screen to the ROP, enter p.
(! to go back, h for Help, q to quit)
```

(c) After selecting a tag, go to Step 4.

4. The selected tag is displayed as follows:

```
OFFICE BASE: T9997-d7
SOFTWARE RELEASE: 5e11
REASON FOR RETURN: DEFECT
EQUIPMENT STATUS:
24 HOUR INDICATOR:
SOURCE OF DIAGNOSTIC REQUEST: AUTOMATIC
DATE/TIME FAILED: 03-12-94 01:05
MCTSI=10-0 PH 4 SEG 1050
TEST      MM
1         H'2
CIRCUIT PACK CODE:
SERIES:
SERIAL NUMBER:
```

Note: The previous step shows an unedited tag. Then, the next prompt is as follows:

```
Please enter the number that corresponds to your selection:
(1) Print the tag
(2) Edit the tag
(3) Select another fault
(! to go back, h for Help, q to quit)
```

(a) For selection 1, the OP TAG REPORT output message is printed on ROP. This will take the dialogue flow back to Step 3.

(b) For selection **2**, the following questions are displayed:

```
QUESTION 1:
Equipment status (default XXX)?
(1) INSTALLING
(2) PRE-CUT
(3) IN SERVICE

Please enter the selected number, or <ENTER> for no change:

QUESTION 2:
24 hour indicator (default XXX)?
(1) YES
(2) NO

Please enter the selected number, or <ENTER> for no change:

QUESTION 3:
Circuit Pack Code (default XXX)
Please enter new circuit pack code or <ENTER> for no change:

QUESTION 4:
Series (default XXX)
Please enter new series/version number or <ENTER> for no change:

QUESTION 5:
Serial number (default XXX)
Please enter new serial number for the circuit pack
or <ENTER> for no change:
```

Where: XXX = The respective current default data.

After getting all the answers to the five questions, redisplay what the user has entered. Then the following will be displayed:

```
Do you want to save these changes?
Please enter y for yes, or n for no, or q to quit:
```

This will take the dialogue flow back to Step **4**.

- (c) For selection **3**, this will take the dialogue flow back to Step **3**.
 - (d) For selection **4**, quit the RTAG user interface.
5. **STOP. YOU HAVE COMPLETED THIS PROCEDURE.**

6.5 Analyze and Clear Non-Diagnosable Switching Module Memory Errors

OVERVIEW

This procedure contains information for clearing an intermittent memory fault in the Module Controller/Time Slot Interchange (MCTSI) in a switching module.

Typically, the fault causes either "REPT SM HWLVL MP PARITY-ERROR" "CORRBITERR" or "MEMSYSTEM" interrupts when the affected side of the MCTSI is active (ACT) or an attempt to restore that side of the MCTSI is failing with an "REPT SM HASHSUM FAILURE" printout. However, the fault is so intermittently "soft" that it cannot be detected by the normal MCTSI diagnostics.

The switching module may have degenerated to a very undesirable state where the ACT side of the MCTSI is detecting memory errors, but it cannot be removed from service because the standby side is out of service (OOS) and cannot be restored due to the errors in the ACT side. Step 3 of the procedure addresses this special case.

PROCEDURE

1. Collect the associated "REPT SM HWLVL" interrupt or "REPT SM HASHSUM FAILURE" printouts.
 2. Using the printouts, determine which side of the MCTSI and which memory pack (TN1661) is most likely causing the problem. To identify a switching module memory board from an address, refer to the appropriate Figures and Tables in 235-600-750, *Output Messages Manual*, for the "REPT SM HWLVL" and the "REPT SM HASHSUM" output messages.
 3. Determine the status of the affected MCTSI side and its mate side. At an ASM workstation, cut-through to the Control Display Page, then type and enter: **1190**
 - (a) If the affected side is OOS and the mate side is ACT, proceed to Step 4.
 - (b) If the affected side is standby (STBY) and the mate side is ACT, using the **REMOVE** poke (or **RMV** input message), remove the affected MCTSI side from service and proceed to Step 4.
 - (c) If the affected side is ACT and the mate side is STBY, using the **SWITCH** poke (or **SW** input message), switch the MCTSI, then remove the affected (now STBY) side and proceed to Step 4.
 - (d) If the affected side is ACT and the mate side is OOS, take the following action:
 1. Diagnose the mate side and verify it is All Tests Passed (ATP).
 2. Using the **INH** input message, temporarily inhibit hardware (HW) error checks in the ACT side.
- Note:** Inhibiting hardware checks may degrade switching module capacity.
3. Using the **RST:MCTSI** input message with the unconditional (UCL) and STBY options, request an unconditional restore of the mate (OOS) side to STBY. Wait for the restore to complete.
 4. Using the **ALW** input message, remove the HW check inhibits previously activated.
 5. Using the **SWITCH** poke (or **SW:MCTSI** input message), switch the MCTSI.

6. Using the **REMOVE** poke (or **RMV:MCTSI** input message), remove the STBY (affected) side from service and proceed to Step 4.

Caution: *Updating the STBY MCTSI from an active MCTSI with errors could potentially corrupt the STBY MCTSI memory.*

4. On the affected MCTSI, execute the MCTSI diagnostic demand Phase 7 (with the Trouble Locating Procedure [TLP] option) several times. Type and enter:

DGN:MCTSI=a-b, PH=7,RPT=3,TLP;

Where: a = The switching module number.
 b = The MCTSI number (0 or 1).

5. Perform Substep (a) or (b) as follows:
 - (a) If the Phase 7 result is ATP, replace the suspected faulty memory pack (as determined in Steps 1 & 2), repeat Step 4, and verify that Phase 7 of the MCTSI diagnostic runs consistently ATP.
 - (b) If the Phase 7 result is not ATP, using the SUSPECTED FAULTY EQUIPMENT printout, determine which pack is most likely causing the failure, replace this pack, and verify that Phase 7 of the MCTSI diagnostic now runs consistently ATP.
6. Once the previous steps have been completed successfully, using the **RESTORE** poke command or the **RST:MCTSI** input message, restore the MCTSI.
7. Verify that the MCTSI restored successfully (no hashsum failure after memory update).

Note: If after restoring the MCTSI the switching module errors continue, the UN517 circuit pack could be the faulty pack.

If the MCTSI restores successfully, perform Substep (a). If the MCTSI does not restore successfully, perform Substep (b).

- (a) Hold the interrupt and diagnostic printouts along with the suspected faulty memory pack for a few days to verify that the memory errors have cleared. Once it is determined that the memory errors have been cleared, attach the interrupt and diagnostic printouts to the faulty memory pack and return the pack to the appropriate repair center.
 - (b) Hold the interrupt and diagnostic printouts along with the suspected faulty memory pack and seek the next higher level of technical assistance to clear the problem.
8. **STOP. YOU HAVE COMPLETED THIS PROCEDURE.**

6.6 Replace EI Paddle Board

OVERVIEW

This procedure provides the necessary steps to replace the *Ethernet*¹ Interface (EI) paddle board at a DRM site and should only be used when the Module Controller/Time Slot Interchange (MCTSI) Trouble Location Procedure (TLP) has indicated the 982YP *Ethernet* Interface paddle board for SM-2000. See Figure 6.6-1.

PROCEDURE

1. At the front of the cabinet, go to the Power/Display pack (410AA) of the SG for the MCTSI that is OOS.
 - The 410AA for MCTSI SG 0 is at position 019-162.
 - The 410AA for MCTSI SG 1 is at position 028-162.

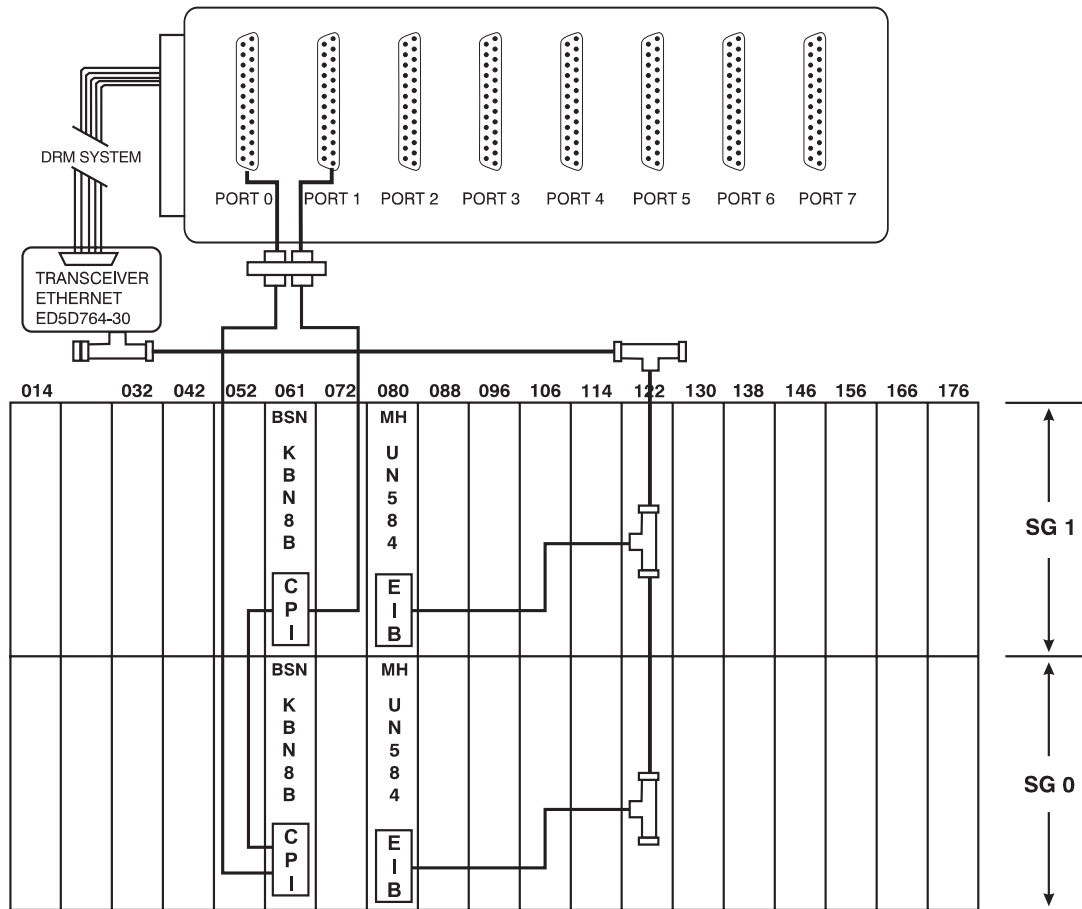

Figure 6.6-1 — *Ethernet* Interface Paddle Board

1. Registered trademark of Xerox Corporation.

Warning: *The static discharge wrist strap must be used to prevent damage to the sensitive circuit pack components from static charges. The wrist strap should be tested before it is used.*

- At the equipment frame, attach the static discharge wrist strap securely to the ESD lug mounted at the top of the frame.
- Power down OOS SG of the MCTSI. To do this, press the OFF button on the 410AA.

Response: 410AA OFF lamp lights.

- Unseat the corresponding UN584 circuit pack. This will prevent possible damage to this circuit pack during the EI paddle board replacement.
 - The UN584 for MCTSI SG 0 is at position 019-088.
 - The UN584 for MCTSI SG 1 is at position 028-088.

Warning: *Do not disconnect the coaxial cables from the T-connectors. Doing so will cause communication loss between the workstation and the switching module.*

- At the MCTSI backplane, disconnect the coaxial EI bus cable that connects to the 982YP MHEIB paddle board.
 - The 982YP for MCTSI SG 0 is at position 019-088.
 - The 982YP for MCTSI SG 1 is at position 028-088.

Warning: *The MHEIB paddle boards are very thin. Handle with care!*

- Gently remove the MHEIB paddle board.

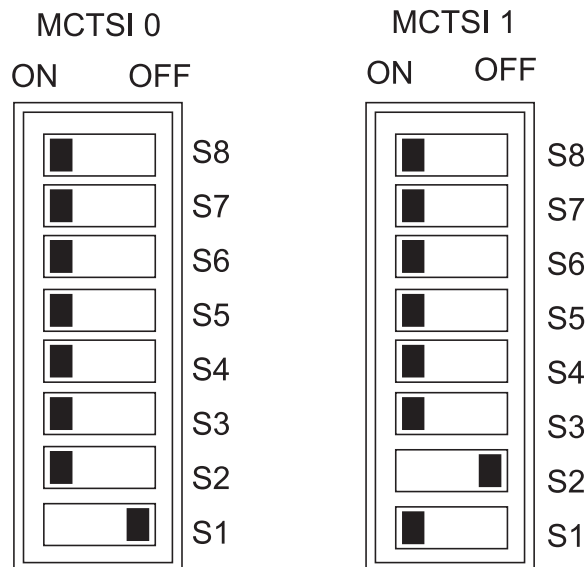

Figure 6.6-2 — SM-2000 DIP Switch Settings

Note: The paddle board contains the *Ethernet* address, verify that the new board's DIP switches are set to the same address as the one being replaced. See Figure 6.6-2 and Table 6.6-1.

Table 6.6-1 — Switching Module DIP Switch Settings

MCTSI	SWITCH SETTINGS
0	S1=OFF, S2-S8=ON
1	S1=ON, S2=OFF, S3-S8=ON

7. Using the same degree of caution, install the new EI paddle board. Be careful not to bend the pins or damage the backplane.
8. Connect the coaxial EI bus cable to the new EI paddle board.
9. At the front of the frame, reseal the UN584 circuit pack.
10. At the out-of-service 410AA, power up the MCTSI SG by pressing the ON button.
Response: The OFF lamp is extinguished.
11. Test the new paddle board. At the MCC terminal, type and enter:
DGN:MCTSI=a-b,PH=12,TLP;
Where: a = The switching module number.
b = The MCTSI number (0 or 1).
12. Is the diagnostic response ATP?
If **YES**, **STOP. YOU HAVE COMPLETED THIS PROCEDURE**
If **NO**, continue with Step 13.
13. **Warning: The following step will cause an expected loss of communication between the switching module and the workstation.**
Replace the T-connector of the new paddle board.
14. Test the new T-connector. Type and enter the input command used in Step 11.
15. Is the diagnostic response ATP?
If **YES**, **STOP. YOU HAVE COMPLETED THIS PROCEDURE**
If **NO**, continue with Step 16.
16. **Warning: The following step will cause an expected loss of communication between the switching module and the workstation.**
Repeat steps 3 and 4, then replace the other T-connector.
17. Test the second new T-connector. Type and enter the input command used in Step 11.
18. Is the diagnostic response ATP?
If **YES**, **STOP. YOU HAVE COMPLETED THIS PROCEDURE.**
If **NO**, continue with Step 19.
19. **Warning: The following step will cause an expected loss of communication between the switching module and the workstation.**

Replace Cable B.

20. Test Cable B. Type and enter the input command used in Step 11.
21. Is the diagnostic response ATP?

If YES, STOP. YOU HAVE COMPLETED THIS PROCEDURE.

If NO, seek technical assistance.

6.7 Replace CPI Paddle Board

OVERVIEW

This procedure provides the necessary steps to replace the Central Processor Intervention (CPI) paddle board at a DRM site and should only be used when the Module Controller/Time Slot Interchange (MCTSI) Trouble Location Procedure (TLP) has indicated the CPI paddle board. See Figure 6.7-1.

PROCEDURE

1. At the front of the cabinet, go to the Power/Display pack (410AA) of the SG for the MCTSI that is OOS.
 - The 410AA for SG 0 is at position 19-021.
 - The 410AA for SG 1 is at position 28-021.

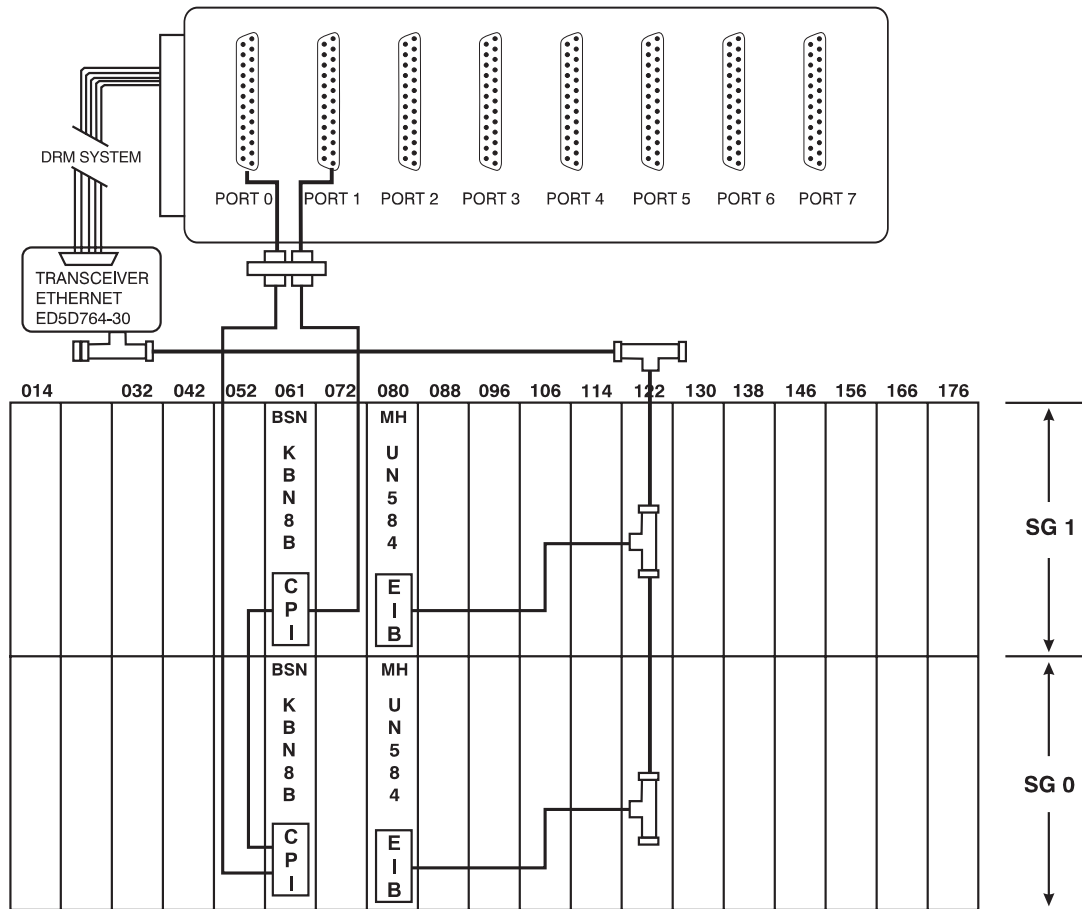

Figure 6.7-1 — CPI Paddle Board

Warning: *The static discharge wrist strap must be used to prevent damage to the sensitive circuit pack components from static charges. The wrist strap should be tested before it is used.*

2. At the equipment frame, attach the static discharge wrist strap securely to the ESD lug mounted at the top of the frame.
3. Power down OOS SG of the MCTSI. To do this, press the OFF button on the 410AA.

Response: 410AA OFF lamp lights.

4. Unseat the corresponding KBN8 circuit pack. This will prevent possible damage to this circuit pack during the CPI paddle board replacement.
 - The KBN8 for MCTSI SG 0 is at position 28-084.
 - The KBN8 for MCTSI SG 1 is at position 19-084.
5. At the MCTSI backplane, disconnect the CPI cable that connects to the 982AAH CPI paddle board.
 - The 982AAH for MCTSI SG 0 is at position 28-084.
 - The 982AAH for MCTSI SG 1 is at position 19-084.

Warning: The CPI paddle boards are very thin. Handle with care!

6. Gently remove the CPI paddle board.
7. Using the same degree of caution, install the new CPI paddle board. Be careful not to bend the pins or damage the backplane.
8. Connect the CPI cable to the new CPI paddle board.
9. At the front of the frame, reseal the KBN8 circuit pack.
10. At the out-of-service 410AA, power up the MCTSI SG by pressing the ON button.

Response: The OFF lamp is extinguished.

11. Test the new paddle board. At the MCC terminal, type and enter:

DGN:MCTSI=a-b,PH=9,TLP;

Where: a = The switching module number.
b = The MCTSI number (0 or 1).

12. Is the diagnostic response ATP?
If **YES**, **STOP. YOU HAVE COMPLETED THIS PROCEDURE.**
If **NO**, continue with Step 13.
13. Replace the appropriate CPI cable to the workstation.
14. Test the new cable. Type and enter the input command used in Step 11.
15. Is the diagnostic response ATP?
If **YES**, **STOP. YOU HAVE COMPLETED THIS PROCEDURE.**
If **NO**, continue with Step 16.
16. Replace the cross-couple CPI cable between the two CPI paddle boards.
17. Test the new cable. Type and enter the input command used in Step 11.
18. Is the diagnostic response ATP?
If **YES**, **STOP. YOU HAVE COMPLETED THIS PROCEDURE.**

If **NO**, seek technical assistance.

Distinctive Remote Module (DRM)

CONTENTS		PAGE
7. SYSTEM RECOVERY		7 - 1
7.1 Perform Office Dead Start Recovery		7.1-1
7.1.1 Load the 3B21 Emulator and Operating System CD-ROM and Boot the AW		7.1.1-1
7.1.2 Propagate Primary Disk to Secondary Disk		7.1.2-1
7.1.3 Load TOP, AM Text, and AM ODD from Multi-Volume Formatted Backup Tapes.		7.1.3-1
7.1.4 Attempt Recovery Boot		7.1.4-1
7.2 Post AM Recovery Cleanup.		7.2-1
7.2.1 Post AM Recovery Cleanup.		7.2.1-1
7.2.2 Restore Switching Module Text on Outboard MHDs		7.2.2-1
7.2.3 Restore the Switching Module ODD		7.2.3-1
7.2.4 Recover from BROOT Configuration		7.2.4-1
7.3 Establish Communication with an Isolated Switching Module.		7.3-1

LIST OF TABLES

Table 7.1.3-1 — Configurations for Dead Start	7.1.3-1
Table 7.2-1 — Recovery Actions	7.2-1

7. SYSTEM RECOVERY

Overview

Note: Although procedure steps involving software commands can be performed via the ASM (via an OA&M cut-through), someone must be present at the DRM office to perform any hardware portions.

This chapter contains system recovery procedures that are unique to the DRM. For more information regarding system recovery, see 235-105-250, **5ESS**[®] *Switch System Recovery Manual*.

Problems that are associated with service outage should be escalated to Lucent Technologies support, either the North American Regional Technical Assistance Center (NARTAC) at 1-800-225-RTAC (1-800-225-7822) or Technical Support Services (TSS) at 1-866-582-3688, as soon as possible. It is understood that some local recovery efforts may be attempted before contacting Lucent Technologies support.

7.1 Perform Office Dead Start Recovery

OVERVIEW

The text and Office Dependent Data (ODD) tapes used in this procedure should be the latest set of backup tapes made for the office.

The AM text tape for the system disk pair must be at the same software update level as the *smtxt* partition on the switching module text tape for vtoc1-MHD2/MHD3.

The first part of this procedure deals with loading the OS/3BEM, Tape Operating Procedure (TOP), text (and ODD) backup tapes, and booting the emulated Administrative Module (AM). The recovery of a completely powered down system may require software and hardware checks being set during the AM recovery. If the ODD is recovered from the backup tape, the Recent Change log files may no longer be consistent with the recovered ODD and a text mismatch may be created between the AM and the switching module.

The second part of the recovery is to have the AM running on the root configuration. This is required because after booting the AM, the AM is running on the backup root partitions. The backup root partitions are normally used for recovery situations; therefore, it is necessary to copy the backup root partitions to the root partitions and reboot the AM.

- Boot the AW using a 3B21 Emulator and Operating System CD-ROM.
 - Initialize the secondary disk.
 - Load the AW disk from the 3B21 Emulator and Operating System CD-ROM or a backup tape, and Boot the AW.
- Propagate the new primary disk to the secondary disk.
- Load TOP, AM text, and AM ODD from multi-volume formatted backup tapes.
- Try recovery boot (in backup root) with 54 (on all configurations).
- If AM recovers, check */no5text/rcv/aimrc* files, and reload AM ODD if needed.
- The following post-AM recovery actions are performed by “Post AM Recovery Cleanup,” Procedure 7.2:
 - Recover the vtoc of any outboard MHD that is new or duplex failed.
 - Initialize AMA disk writer.
 - Recover the switching module text on the second disk pair if software update levels of AM text and switching module text are not matched.
 - Restore switching module ODD from switching module ODD tape(s).
 - Clear Recent Change Logs and RC Backout flag.
 - If the switching module is not running, initialize the switching module.
 - Restore MHDs to duplex.
 - LATER: Copy backup partitions to root partitions (duplexed disks) and boot the AM on root configuration with EAI poke 53.

Note: In the event that errors are detected during this procedure, take appropriate corrective action using the output messages manual as a first-level reference; and then if necessary, **seek technical assistance**.

PROCEDURE

1. For an AW with a 3B21 Emulator and Operating System CD-ROM, begin office dead start recovery with “Load the 3B21 Emulator and Operating System CD-ROM and Boot the AW,” Procedure 7.1.1.

7.1.1 Load the 3B21 Emulator and Operating System CD-ROM and Boot the AW

OVERVIEW

This part of the procedure provides a description for recovering the Administrative Workstation (AW) operating system and the 3B21 emulator. It uses the 3B21 Emulator and Operating System CD-ROM to restore the AW system boot disk, either from the CD-ROM or from a backup tape.

PROCEDURE

1. Stop the AW. See “Halt the Administrative Workstation,” Procedure 4.2.
2. Load the 3B21 Emulator and Operating System CD-ROM into the DVD/CD-ROM drive.

Caution: *Booting from this CD-ROM and loading from the CD-ROM or a backup tape will format the AW disks and overwrite the operating system and emulator with data from the CD-ROM or tape. After this procedure is executed, load the remaining generic backup tapes.*

3. Enter the following command at the **ok** prompt to boot the AW from the CD-ROM:

boot cdrom

If “cdrom” is not defined correctly, use the following commands to verify the DVD/CD-ROM drive device ID and set the CD-ROM device alias:

For *Netra*¹ t 1120

```
probe-scsi  
devalias  
nvalias cdrom /pci@1f,4000/scsi@3/disk@5,0:f
```

For *Netra* 20

```
devalias  
nvalias cdrom /pci@8,700000/scsi@6/disk@6,0:f
```

For *Netra* 240

```
devalias  
nvalias cdrom /pci@1e,600000/ide@d/cdrom@0,0:f
```

When the AW starts to boot from the CD-ROM, messages similar to those shown in the following examples are output on the system console:

For *Netra* t 1120

```
Resetting ...  
screen not found.  
Can't open input device  
Keyboard not present. Using ttya for input and output.
```

```
Sun Ultra 60 UPA/PCI (UltraSPARC-II 440 MHz), No keyboard  
OpenBoot 3.29, 512 MB memory installed, Serial #13079967  
Ethernet address 8:0:20:c7:95:9f, Host ID: 80c7959f.
```

```
Initializing Memory
```

1. Trademark of Sun Microsystems, Inc.

```
Rebooting with command: boot cdrom
Boot device: /pci@1f,4000/scsi@3/disk@5,0:f File and args:
SunOS Release 5.8 Version Generic-108528-13 64-bit
Copyright 1983-2001 Sun Microsystems, Inc. All rights reserved.
```

```
·
·
```

For Netra 20

Resetting ...

```
Sun Netra T4 (UltraSPARC-III+), No keyboard
Copyright 1998-2002 Sun Microsystems, Inc. All rights reserved.
OpenBoot 4.5, 512 MB memory installed, Serial #51344136.
Ethernet address 0:3:ba:f:73:8, Host ID: 830f7308.
```

```
Initializing Memory
Rebooting with command: boot cdrom
Boot device: /pci@8,700000/scsi@6/disk@6,0:f File and args:
SunOS Release 5.8 Version Generic-108528-13 64-bit
Copyright 1983-2001 Sun Microsystems, Inc. All rights reserved.
```

```
·
·
```

For Netra 240

Resetting ...

```
Netra 240, No keyboard
Copyright 1998-2003 Sun Microsystems, Inc. All rights reserved.
OpenBoot 4.11.4, 1024 MB memory installed, Serial #59810525.
Ethernet address 0:3:ba:90:a2:dd, Host ID: 8390a2dd.
```

```
Initializing Memory
Rebooting with command: boot cdrom
Boot device: /pci@1e,600000/ide@d/cdrom@0,0:f File and args:
SunOS Release 5.8 Version Generic-108528-29 64-bit
Copyright 1983-2003 Sun Microsystems, Inc. All rights reserved.
```

```
·
·
```

After the system boots on the CD-ROM, the 3B21 Emulator and Operating System CD-ROM Installation main menu is displayed.

4. If the Emulator and Operating System backup tape is available, skip to Step 7 to restore the AW boot disk from the backup tape.

Otherwise, continue with the next step to restart the AW boot disk from the CD-ROM.

5. From the main menu, select "Format and Load the Primary Disk from CD-ROM." Answer **yes** to the confirmation. If you select a task by mistake, answer **no** to the confirmation.

Response:

You have chosen to format and load the primary disk from CD-ROM.

WARNING:

If you continue, the primary disk operating system partitions will be overwritten with data from the CD-ROM and its MHD

partitions are
preserved.

Do you want to continue? (yes/no) **yes**

This task will take approximately 30 minutes. When it is completed, you will be prompted to press Return. When the prompt appears, press **Return**.

6. Skip to Step 9.
7. Insert the Emulator and Operating System backup tape into the DAT drive using "Load Tape in DAT Tape Drive Unit," Procedure 4.19.
8. From the main menu, select "Format and Load the Primary Disk from Backup Tape." Answer **yes** to the confirmation. If you select a task by mistake, answer **no** to the confirmation.

Response:

You have chosen to format and load the primary disk from a backup tape. Please ensure that an Emulator and Sun OS backup tape is in the DAT drive.

WARNING:

If you continue, the primary disk operating system partitions will be overwritten with data from the backup tape and its MHD partitions are preserved.

Do you want to continue? (yes/no) **yes**

This task will take approximately 30 minutes. When it is completed, you will be prompted to press Return. When the prompt appears, press **Return**.

9. From the main menu, select "Exit and Boot the Workstation" (5e14.1 – 5e16.1) or "Boot the Workstation on the Default Boot Disk" (5e16.2 and later). Answer **yes** to the following confirmation. If you select a task by mistake, answer **no** to the confirmation

Response:

You have chosen to boot the workstation...

Do you want to continue? (yes/no) **yes**

The AW will boot and automatically start the AM emulator.

10. Is the AW booted?

If **YES**, Continue with "Propagate Primary Disk to Secondary Disk," Procedure 7.1.2.

If **NO**, seek technical assistance.

7.1.2 Propagate Primary Disk to Secondary Disk

PROCEDURE

1. If the *UNIX*¹ console page is displayed, switch to the MCC of the AW, by holding down the Ctrl key and pressing Enter (not Return).
2. If the emulator is running, halt the emulator. See "Halt the Administrative Module (AM) Emulator," Procedure 4.1.
3. Switch to the *UNIX* Console of the AW by holding down the Ctrl key and pressing Enter (not Return).
4. If a login prompt does not appear, press Return repeatedly until one appears.
5. At the login prompt, login as **awadmin**, for example:
attaws console login: **awadmin**
6. From the Administrative Workstation Main Menu, select "Initialize a New Workstation Disk".
7. From the Disk Initialization menu, select "Execute initialization of a new workstation disk." Answer **yes** to the following confirmation. If you select a task by mistake, answer **no** to the confirmation.

Response:

You have chosen to initialize a new workstation disk. If the Emulator is running, it must be halted before continuing. Refer to the Main Menu item of Halt the Emulator.

Do you want to continue? (yes/no) **yes**

This operation will take approximately 30 minutes.

8. Has the Initialize a New Workstation Disk operation completed with the following response?
Newdisk completed ...
Press return to continue
If **YES**, press return and proceed with Step 9.
If **NO**, seek technical assistance.
9. From the "Disk Initialization Menu", select "Return to the main menu".
10. Is the AW a *Netra*² 20 or *Netra* 240?
If **YES**, proceed with Step 11.
If **NO**, proceed with Step 15.
11. From the Administrative Workstation Main Menu, select "Backup the workstation Operating System/Emulator to disk". If you select a task by mistake, answer **no** to the confirmation, and the main menu will return.

1. Registered trademark of The Open Group in the United States and other countries.

2. Registered trademark of Sun Microsystems, Inc.

12. From the Operating System/Emulator Backup To Secondary Disk Menu, select “Execute backup of the workstation Operating System/Emulator to disk”. Answer **yes** to the following confirmation. If you select a task by mistake, answer **no** to the confirmation.

Response:

You have chosen to backup the workstation Operating System/Emulator to disk.

Do you want to continue? (yes/no) **yes**

This task will take approximately 15 minutes.

13. Set the *Netra 20* or *Netra 240* secondary disk bootable. Enter **yes** to the following response:

Do you want to set the secondary disk bootable? **yes**

When completed, you will be prompted to press return. When the prompt appears, press return.

14. From the “Operating System/Emulator Backup To Secondary Disk Menu”, select “Return to the main menu”.

15. From the Administrative Workstation Main Menu, select “Boot the Workstation”. Answer **yes** to the following confirmation. If you select a task by mistake, answer **no** to the confirmation.

Response:

You have chosen to boot the workstation. If the Emulator is running, it must be halted before continuing. Refer to the Main Menu item of Halt the Emulator.

Do you want to continue? (yes/no) **yes**

16. If the *UNIX* console page is displayed, switch to the MCC of the AW, by holding down the Ctrl key and pressing Enter (not Return).

17. Is the AW booted with the AM EAI page available from the MCC?

If **YES**, press return and proceed with Step **19**.

If **NO**, seek technical assistance.

18. Proceed to the “Load TOP, AM Text, and AM ODD from Multi-Volume Formatted Backup Tapes”, Procedure 7.1.3.

7.1.3 Load TOP, AM Text, and AM ODD from Multi-Volume Formatted Backup Tapes

OVERVIEW

The steps in this procedure loads AM text first; then if needed, loads the AM ODD. A multi-volume DAT should contain all of the software media needed to dead start the office (TOP, AM text, and AM ODD logical volumes).

PROCEDURE

1. Switch to the MCC by holding down the Ctrl key and pressing **Enter** (not Return) key.
Load the backup tape.
2. In the following step, select the first configuration from Table 7.1.3-1.

Table 7.1.3-1 — Configurations for Dead Start

No.	Configuration to Enter	Configuration
1	20,30,33	CU0 MHD0 Pri Disk
2	22,30,33	CU0 MHD1 Sec Disk

Note: If the tape loading fails the initial loading, try rewinding the tape and entering another **55**. If the tape operation continues to fail, take action described in 235-600-601, *Process Recovery Manual*, and/or **seek technical assistance**.

3. Enter the EAI page commands for the selected configuration from Table 7.1.3-1.
Response: Disk indicators are SET,
Backup indicator is SET,
Min Config indicator is clear.
4. Obtain the latest AM ODD and AM text backup tape.
5. Mount the DAT backup that contains AM text into the tape drive.
6. On EAI page, type and enter: **55**.
7. Did the EAI Page respond with one of the following:
Boot? (y/n) or
BkRt Set! Boot (y/n)?
If **YES**, then type and enter **y** and continue with the next step.
If **NO**, then continue with the next step.
8. If the response is **ignored**, enter **55** again.
9. Response:
DAT moves.
PRM_0 E151 33xx EEEE EEEE hh hh hh displayed on EAI page (when completed and DAT tape rewinds).
Note: PRM_0 F0da zz00 0000 0000 xx xx xx (Where zz = 27, 28, 29, 2A)
Indicates a bad TOP tape.

The following provides LDFT descriptions applicable to PRMs encountered during this procedure.

PRM	Description
PRM_0 E151 54xx xxxx xx xx xx	Tape version
PRM_0 E151 57xx xxxx xx xx xx	Tape loading in progress
PRM_0 E151 58xx xxxx xx xx xx	Mount next tape
PRM_0 E151 59xx xxxx xx xx xx	Tape load complete
PRM_0 F151 xxxx xxxx xx xx xx	Tape load problem

10. Is **PRM_0 E151 33xx EEEE EEEE hh hh hh** present on EAI page? Note: the PRM displayed on the EAI Page may take from 2 to 5 minutes.

If **YES**, then continue with the next step.

If **NO**, then consult 235-600-601, *Process Recovery Manual*. Using Table 7.1.3-1 in Step 2, select the next configuration and repeat from Step 3.

11. Does the multi-volume DAT contain more than one backup session?

If **YES**, continue with the next step.

If **NO**, go to Step 13.

12. Enter the application parameter to output the DAT header.

Enter the following poke: **42**.

Enter the following parameter type: **h**.

Note: Be patient. A series of PRMs should be displayed (or printed) that list the backup sessions and logical volumes on the DAT. Decode the record the DAT session/volume numbers. Once the header dump is completed, PRMs print that indicate the tape load program is waiting for the next request. The volume numbers, which are fixed values, correspond to the following logical volumes:

Waiting For Next Request: **PRM_0 E151 33xx EEEE EEEE**

Volume Information: **PRM_0E151 35yy mmdd SSvv** Volume Information:

PRM_0E151 35yy mmdd SSvv

Where:

- SS = Session number.
- vv = Volume number.
- mm = Month (in hex) of session.
- dd = Day (in hex) of session.
- yy = Year (in hex) of session.
- vv = Volume Number
 - 0 = TOP TAPE
 - 1 = AM TEXT
 - 2 = AM ODD
 - 3 = SM TEXT
 - 4 = SM ODD 1
 - 5 = SM ODD 2
 - 6 = SM ODD 3

13. Is the DAT header information displayed (or printed)?

If **YES**, wait for the next request PRM; then continue with next step.

If **NO**, enter EAI poke **43** (clear application parameters), then repeat from Step **3**.
If tape read problems continue, **seek technical assistance**.

14. Enter the parameters for the AM text session/volume you want to load (perform the following substeps, then observe Notes 1, 2, and 3).

(a) Type and enter: **42**

(b) Type and enter: **s** (session)

(c) Type and enter: **42**

(d) Enter the session number for the AM text you want to load: **1**

Observe the session **PRM_0 E151 3331 FF01 EEEE** displayed on the EAI page. (See Note 1.)

(e) Type and enter: **42**

(f) Type and enter: **v** (volume)

Observe the volume **PRM_0 E151 3376 FF01 FFEE** displayed on the EAI page.

(g) Type and enter: **42**

(h) Type and enter: **1** (AM text=1)

Observe the volume **PRM_0 E151 3331 FF01** displayed on the EAI page.

(i) Observe **PRM_0 E151 3600 FF01 FF01**.

Sample Volume Search Results: **PRM_0 E151 36xx FFss FFvv**

Where: xx = 00 for volume was found.
 xx = ff for volume was not found.
 ss = Session number entered.
 vv = Volume number entered.

Note 1: Step **14.d** assumes that this is a single session multi-volume DAT.
If other session is to be used, enter the correct session number.

Note 2: If the session/volume request PRM is never printed, type and enter: **43** to clear all application parameters, then repeat this step.

Note 3: If the volume was found, it takes approximately 20 minutes to load AM text. A progression PRM prints while the tape is being loaded. If the volume is not found, check the values entered or select another session/volume, or **seek technical assistance**.

Tape Version	PRM_0 E151 54xx xxxx xxxx xx xx xx
Program Version	PRM_0 E151 7400 xxxx 0000 hh hh
Tape Load Progression	PRM_0 E151 57xx xxxx xxxx
Tape Load Completion	PRM_0 E151 59xx xxxx xxxx
Ready for Next Request	PRM_0 E151 33xx EEEE EEEE hh hh hh
Tape Load Problem	PRM_0 E151 xxxx xxxx xxxx
Disk Initialization	PRM_0 E151 88xx xxxx xxxx

15. Did the tape load completion PRM print after the progression PRMs?

If YES, AM text has been loaded, continue with the next step.

- If NO, analyze any failure PRMs. **Seek technical assistance.**
16. Is the AM ODD on the disk being loaded known to be bad (that is, this disk has just been replaced and never been on line or is known to be corrupted)?
- If YES, proceed to Step **18**.
- If NO, continue with the next step.
17. Has the configuration being loaded been tried unsuccessfully while loading AM text only?
- Load AM ODD
- If **YES**, continue with the next step.
- If **NO**, proceed to "Attempt Recovery Boot," Section 7.1.4, Step **4**.
18. With the DAT that contains the AM ODD in DAT drive, enter the EAI parameters to load AM ODD (perform the following substeps, then observe Notes 1, 2, and 3).
- (a) Type and enter: **42**
- (b) Type and enter: **d** (database)
- Observe the database **PRM_0 E151 3364 EEEE EEEE** displayed on the EAI page.
- (c) Type and enter: **42**
- (d) Type and enter: **s** (session)
- Observe the session **PRM_0 E151 3373 FFEE EEEE** displayed on the EAI page.
- (e) Type and enter: **42**
- (f) Enter the session number for the AM ODD you want to load: **1**
- Observe the session **PRM_0 E151 3331 FF01 EEEE** displayed on the EAI page. (See Note 1.)
- (g) Type and enter: **42**
- (h) Type and enter: **v** (volume)
- Observe the volume **PRM_0 E151 3376 FF01 FFEE** displayed on the EAI page.
- (i) Type and enter: **42**
- (j) Enter the following volume number for AM ODD: **2**
- Observe the volume **PRM_0 E151 3332 FF02** displayed on the EAI page.
- (k) Observe **PRM_0 E151 3600 FF01 FF02**.
- Sample Volume Search Results: **PRM_0 E151 36xx FFss FFvv**
- Where: **xx** = 00 for volume was found.
 xx = ff for volume was not found.
 ss = Session number entered.
 vv = Volume number entered.

Note 1: Step **18d** assumes that this is a single session multi-volume DAT. If other session is to be used, enter the correct session number.

Note 2: If the session/volume request PRM is never printed, type and enter: **43** to clear all application parameters, then repeat this step.

Note 3: If the volume was found, it takes approximately 10 minutes to load AM ODD. A progression PRM prints while the tape is being loaded. If the volume is not found, check the values entered or select another session/volume, or **seek technical assistance**.

Tape Version	PRM_0 E151 54xx xxxx xxxx xx xx xx
Program Version	PRM_0 E151 7400 xxxx 0000 hh hh
Tape Load Progression	PRM_0 E151 57xx xxxx xxxx xx xx xx
Tape Load Completion	PRM_0 E151 59xx xxxx xxxx xx xx xx
Ready for Next Request	PRM_0 E151 33xx EEEE EEEE hh hh hh
Tape Load Problem	PRM_0 E151 xxxx xxxx xxxx xx xx xx

19. Did the tape load completion PRM follow the progression PRMs?

If YES, AM ODD has been loaded., continue with the next step.

If NO, analyze any failure PRMs. **Seek technical assistance**.

20. At this point in the procedure, the loading of the AM text and AM ODD tapes is completed. The next step is to perform a system initialization while requesting a backout of recent changes. The reason for requesting the backout of AM recent changes is that any recent change log files which may exist on the disk will be inconsistent with the Office Dependent Data (ODD) disk image just read into the system. Before performing the system initialization, be sure that the **Backup Root** indicator is **SET** and the **Min Config** indicator is **clear** on the EAI page.

Note: If the system has been thrashing because of switching module communication problems or if communication to the switching module is known to be bad, then set hardware and software checks on the EAI page (Poke **34** and **36**).

7.1.4 Attempt Recovery Boot

PROCEDURE

1. On the EAI page, type and enter: **42;h;54;** to boot the AM.
2. Did the EAI Page respond with one of the following:
Boot? (y/n) or
BkRt Set! Boot (y/n)?

If **YES**, type and enter: **y** and continue with the next step.

If **NO**, continue with the next step.

3. Did the AM initialization complete (Page 111/112 displayed)?
If **YES**, proceed to Step **47**.
If **NO**, proceed to Step **7**.

4. The next step is to perform an AM initialization.

Note 1: If the system has been thrashing because of switching module communication problems or if communication to the switching module is known to be bad, then set hardware and software checks on the EAI page (Poke **34** and **36**).

Note 2: Forces must not be changed.

Before performing the AM initialization, be sure that the **Backup Root** indicator is **SET** and the **Min Config** indicator is **clear** on the EAI page.

On EAI page, type and enter: **54** to initialize the AM.

5. Did the EAI Page respond with one of the following:
Boot? (y/n) or
BkRt Set! Boot (y/n)?

If **YES**, type and enter: **y** and continue with the next step.

If **NO**, continue with the next step.

6. Did the AM initialization complete (Page 111-112 displayed)?
If **YES**, proceed to Step **9**.

If **NO**, analyze the initialization failure and continue with the next step.

7. Have both configurations in "Load TOP, AM Text, and AM ODD from Multi-Volume Formatted Backup Tapes," Section 7.1.3, Step **2**, been tried?

If **YES**, continue with the next step.

If **NO**, using Table 7.1.3-1, select the next configuration, and repeat "Load TOP, AM Text, and AM ODD from Multi-Volume Formatted Backup Tapes," Section 7.1.3, Step **3**.

8. Have both configurations in "Load TOP, AM Text, and AM ODD from Multi-Volume Formatted Backup Tapes," Section 7.1.3, Step **2**, been tried loading both AM text and AM ODD?

If **YES**, **seek technical assistance** or consult 235-600-601, **5ESS® Switch Process Recovery Messages Manual**.

If **NO**, select the other configuration using Table 7.1.3-1, select the next configuration, and repeat "Load TOP, AM Text, and AM ODD from Multi-Volume Formatted Backup Tapes," Section 7.1.3, Step 3, loading both AM text and AM ODD backup tapes.

9. The AM has booted with only AM text being loaded from backup tape. The AM ODD and **ALL** disks containing switching module ODD must be recovered from tape if any MHD pairs that contain switching module ODD are shown as duplexed failed. On MCC Page 111, is the MHD pair that contains switching module ODD shown as duplexed failed so that the switching module ODD on that disk is known to be bad?

If **YES**, proceed to Step 20.

If **NO**, continue with the next step.

10. When the system booted, ODD1 partitions were loaded. However, the system may have been running on ODD2 before the recovery of the AM TEXT from tape. Verify which is the more recent AM ODD file.
11. Read the backup ODD pointer from the ODD partition.

Enter message: **DUMP:FILE:ALL, FN="/no5odd/data0/bk.aimrc";**

Response: **DUMP FILE ALL COMPLETED x no5doddx is the current disk odd**

Where: x = Indicator of previously active odd (1 or 2).

12. What was the previously active ODD?

If **1**, proceed to Step 47.

If **2**, continue with the next step.

13. Pointers to the AM ODD files must be switched and the AM rebooted.

Type and enter:

COPY:FILESYS:FILE, SRC="/no5text/rcv/aimrc", DEST="/no5text/rcv/aimrc.tmp";

Response: COPY FILESYS FILE COMPLETED

14. Type and enter:

COPY:FILESYS:FILE, SRC="/no5text/rcv/aimrc2", DEST="/no5text/rcv/aimrc";

Response: COPY FILESYS FILE COMPLETED

15. Type and enter:

COPY:FILESYS:FILE, SRC="/no5text/rcv/aimrc.tmp", DEST="/no5text/rcv/aimrc2";

Response: COPY FILESYS FILE COMPLETED

16. Type and enter:

CLR:FILESYS:FILE, FN="/no5text/rcv/aimrc.tmp";

Response: CLR FILESYS FILE COMPLETED

17. On EAI page, type and enter: **53** to boot the AM.

18. Did the EAI Page respond with one of the following:
Boot? (y/n) or
BkRt Set! Boot (y/n)?
If **YES**, type and enter: **y** and continue with the next step.
If **NO**, continue with the next step.
19. Did the AM initialization complete successfully?
If **YES**, proceed to Step **47**.
If **NO**, **seek technical assistance** and analyze the initialization failure.
20. Since switching module ODD must be loaded from tape because of a duplex outboard disk failure, AM ODD must be loaded from tape.
Inhibit Recent Change. At the MCC Page 110, type and enter either: **605** or
INH:CORCS!
21. At the MCC Page 110, type and enter either: **606** or
INH:RC!
22. Type and enter:
INH:REORG!
23. Access the MCC Page 120.
Note: If the AM boots before the tapes are read in, the AM ODD that will become active is the ODD BEFORE the last AM Backup.
24. Unmount the active partition (/dev/no5aodd1). Type and enter:
INH:FILESYS:UMOUNT, FN= "/dev/no5aodd1";
Response: INH FILESYS UMOUNT COMPLETED
25. To determine if the no5aodd1 partition is mounted, type and enter:
OP:STATUS:FILESYS;
26. Is the inactive partition /dev/no5aodd1 shown as mounted on /no5odd/data0?
If **YES**, **seek technical assistance**
If **NO**, continue with the next step.
27. Make the active partitions inactive and the inactive partitions active. Type and enter:
COPY:FILESYS:FILE, SRC= "/no5text/rcv/aimrc", DEST="/no5text/rcv/aimrc.tmp";
Response: COPY FILESYS FILE COMPLETED
28. Type and enter:
COPY:FILESYS:FILE, SRC="/no5text/rcv/aimrc2", DEST= "/no5text/rcv/aimrc";
Response: COPY FILESYS FILE COMPLETED
29. Type and enter:

```
COPY:FILESYS:FILE, SRC = "/no5text/rcv/aimrc.tmp  
"DEST="/no5text/rcv/aimrc2";
```

Response: COPY FILESYS FILE COMPLETED

30. Type and enter:

```
CLR:FILESYS:FILE, FN="/no5text/rcv/aimrc.tmp";
```

Response: CLR FILESYS FILE COMPLETED

31. Load AM ODD. Type and enter:

```
DUMP:FILE:ALL, FN = "/no5text/bkup/aodd.ptn";
```

32. Does contents of /no5text/bkup/aodd.ptn agree line-for-line with either of the following:

```
/dev/no5aodd1/  
dev/no5dodd1
```

If **YES**, continue with the next step.

If **NO**, seek technical assistance.

33. Type and enter:

```
COPY:FILESYS:FILE, SRC="/no5text/bkup/aodd.ptn", DEST = "/tmp/tmpodd.ptn";
```

Response: COPY FILESYS FILE COMPLETED

34. Mount the AM ODD backup tape on the tape drive.

35. To read the AM ODD backup tape into the ODD partitions, type and enter:

```
EXC:ENVIR:UPROC, FN= "/etc/mkdsk", ARGS= "-i"-"/dev/mt00"-"-d"-  
/dev/vtoc"-"-p"-"/tmp/tmpodd.ptn";
```

Response: EXC ENVIR UPROC COMPLETED

36. Was the set of AM ODD backup tapes read into the AM ODD partitions successfully?

If **YES**, continue with the next step.

If **NO**, seek technical assistance

37. Type and enter:

```
CLR:FILESYS:FILE, FN = "/tmp/tmpodd.ptn";
```

Response: CLR FILESYS FILE COMPLETED

38. Type and enter:

```
COPY:FILESYS:FILE, SRC="/no5text/rcv/aimrc", DEST="/no5text/rcv/aimrc.tmp";
```

Response: COPY FILESYS FILE COMPLETED

39. Type and enter:

```
COPY:FILESYS:FILE, SRC="/no5text/rcv/aimrc2", DEST="/no5text/rcv/aimrc";
```

Response: COPY FILESYS FILE COMPLETED

40. Type and enter:

```
COPY:FILESYS:FILE,SRC ="/no5text/rcv/aimrc.tmp", DEST  
="/no5text/rcv/aimrc2";
```

Response: COPY FILESYS FILE COMPLETED

41. Type and enter:

```
CLR:FILESYS:FILE,FN="/no5text/rcv/aimrc.tmp";
```

Response: CLR FILESYS FILE COMPLETED

42. Type and enter:

```
DUMP:FILE:ALL,FN= "/no5text/rcv/aimrc";
```

Response: DUMP FILE ALL COMPLETED 1 no5dodd1 is the current disk odd

43. Was no5dodd1 printed in the previous step?

Note: At this point in the procedure, the loading of the AM text and AM ODD tapes is completed. The next step is to perform a system initialization while requesting a backout of recent changes. The reason for requesting the backout of AM recent changes is that any recent change log files which may exist on the disk will be inconsistent with the Office Dependent Data (ODD) disk image just read into the system. Before performing the system initialization, be sure that the **Backup Root** indicator is **SET** and the **Min Config** indicator is **clear** on the EAI page.

If **YES**, continue with the next step.

If **NO**, **seek technical assistance**.

44. On the EAI page, type and enter: **42;h;54;** to boot the AM.

45. Did the EAI Page respond with one of the following:

```
Boot? (y/n) or  
BkRt Set! Boot (y/n)?
```

If **YES**, type and enter: **y** and continue with the next step.

If **NO**, continue with the next step.

46. Did the AM initialization complete (Page 111/112 displayed)?

If **YES**, continue with the next step.

If **NO**, **seek technical assistance**.

47. The AM is now running on the backup root file system with a different AMODD. Now do post-AM recovery actions to recover the switching module ODD and switching module text (if necessary), and return to the primary root file system.

Go to "Post AM Recovery Cleanup," Procedure 7.2.

48. **STOP. YOU HAVE COMPLETED THIS PROCEDURE.**

7.2 Post AM Recovery Cleanup

OVERVIEW

You have reached this point because the Administrative Module (AM) was booted such that further recovery action is required. This procedure will deal with switching module related recoveries. This procedure will also deal with outboard disks that have experienced failures that have rendered those disks unusable (duplex disk failure).

The overall objective of this procedure is to have the AM running in the root configuration on the system moving head disks (MHD). If the AM was booted from a disk that was loaded from tape, the AM is running on the backup root partitions. The backup root partitions are normally used for recovery from tape situations; therefore, it is necessary to copy the backup root partitions to the root partitions and reboot the AM. If the AM was booted from a disk that was a software backup disk, the system MHDs must be restored to normal and the software backup disk returned to backup status.

Once the office is processing calls and has stabilized, the AM and disks should be returned to a duplex configuration. Also, the AM backout indicator on Master Control Center (MCC) Page 110 should be returned to normal. This is accomplished by first clearing the recent change log files and then clearing the AM recent change backout indicator. Also, switching module ODD of the same vintage as the AM ODD must be loaded in from tape so there is consistency between the AM and switching module ODDs.

If no MHD2/MHD3 text tape (switching module text tape) at the same software update level as the AM text restored from the backup media is available, install an older switching module text tape now and obtain a tape of the same software update level as the AM text to install later. The Backout Last Overwrite (BOLO) feature may not be usable following an AM recovery from tape or Software Backup (SWBU) disk and will not be usable if MHD2/MHD3 must be replaced with a new disk.

Table 7.2-1 — Recovery Actions

AM RECOVERY FROM:	RECOVERY ACTION SM TEXT, PUMP SM	SM TEXT, SM ODD PUMP SM	RECOVER BASE MHD	RESTORE ROOT & REBOOT
Original Disk	—	—	—	Z
AM Text Tape	X	—	—	X
AM Text & ODD Tapes	—	X	—	X
X = Actions that are required. Z = Actions that are required if AM recovered on the backup root.				

Post AM Recovery Subprocedure Overview

- Recover the Volume Table Of Contents (VTOC) of any outboard MHD that is new or duplex failed, and initialize Automatic Message Accounting (AMA) Disk Writer.
- Recover the switching module text on the second disk pair if necessary to maintain consistent software update levels between AM text and switching module text.

- If AM recovered from backup tape or disk, restore switching module ODD from switching module ODD tape(s), and pump the switching module.
- Restore primary MHDs.
- If AM recovery was from a software backup disk, restore that disk to spare status.
- Allow Power Switch Monitor scanning of software backup disks.
- Restore control units (CU) and all MHDs to duplex.
- LATER: If the AM recovered on the backup root file system, copy backup partitions to root partitions. Then after duplexing the disks, reboot the AM on root configuration with 53.

PROCEDURE

1. Follow these subprocedures in the order in which they are presented.
 - “Post AM Recovery Cleanup,” Subprocedure 7.2.1.
 - “Restore Switching Module Text on Outboard MHDs,” Subprocedure 7.2.2.
 - “Restore the Switching Module ODD,” Subprocedure 7.2.3.
 - “Recover from BROOT Configuration,” Subprocedure 7.2.4.

7.2.1 Post AM Recovery Cleanup

PROCEDURE

- Inhibit diagnostic sources until disk restore activities are complete. Type and enter:
**INH:DMQ:SRC=ADP;
INH:AUD=SODD,FULL;**
- Clear any active diagnostics from the system. Type and enter:
OP:DMQ;
Response: **REQUEST ACTIVE
0 RST MHD 1 BPH=1 EPH=100
SOURCE = ADP PRIORITY = 512
STATUS = ACTIVE

REQUEST WAITING

1 RST MHD 3 BPH=1 EPH=100
SOURCE = MAN PRIORITY = 0
STATUS = WAITING

INHIBIT SOURCES

NONE

OP DMQ COMPLETED**
- If MHD actions are active or waiting, type and enter:
STP:DMQ:MHD=x,zzzzzz;
Where: x = Unit number of MHD
zzzzzz = **ACTIVE** and/or **WAITING** as per output message from previous step.
- On MCC Page 111, are MHD 2/3 shown as duplexed failed?
If **YES**, continue with the next step.
If **NO**, continue with Step 8.
- At the MCC, write the VTOC file to the MHD being recovered. Type and enter:
EXC:ENVIR:UPROC,FN="/etc/rcvtoc",ARGS=2;
Where: 2 = MHD number to be restored
Response: **EXC ENVIR UPROC COMPLETED
vcp: disk copy completed
vcp: disk copy completed
/etc/rcvtoc VTOC READ AND COMPARE
SUCCESSFUL**
- Restore MHD 2. Type and enter:
RST:MHD=2

Where: 2 = MHD number to be restored

Response: RST MHD 2 TASK y MSG STARTED
RST MHD 2 IN PROGRESS
RST MHD 2 COMPLETED

7. The AMA partitions must now be cleaned up. Initialize AMA Disk Writer. Type and enter:

INIT:AM,AMDW1,FPI;

Response: REPT AMA DISK WRITER FOR STREAM ST1
RECORDING TO DISK SUSPENDED
REPT AMA DISK WRITER FOR STREAM ST1
TERMINATION CODE 2
REPT AMA DISK WRITER FOR STREAM ST1
ERROR CODE 6
REPT AMA DISK WRITER FOR STREAM ST1
INITIALIZATION COMPLETE
REPT AMA DISK WRITER FOR STREAM ST1
RECORDING TO DISK RESUMED

8. Verify software update levels of AM text (/no5text) and switching module (/no5text/im). Type and enter:

OP:VERSION;

OP VERSION	mm dd, yyyy	
PARTITION	VERSION	BWM
ECD	5ex(x)xx.xx	
/	5ex(x)xx.xx	BWMnn-nnnn
/etc	5ex(x)xx.xx	BWMnn-nnnn
/unixa	5ex(x)xx.xx	BWMnn-nnnn
/no5text/im	5ex(x)xx.xx	BWMnn-nnnn
/no5text	5ex(x)xx.xx	BWMnn-nnnn

9. Are the software update levels of /no5text and /no5text/im the same?

If **YES**, continue with the next step.

If **NO**, go to "Restore Switching Module Text on Outboard MHDs," Subprocedure 7.2.2, to recover switching module text, then return to the next step.

10. **ALL** disks containing switching module ODD must be recovered from tape if any of the following conditions exist:

- AM ODD recovered on an MHD restored from AM ODD backup tapes,
- Any outboard MHD containing switching module ODD was duplexed failed so that the switching module ODD on that disk is known to be bad.

Do any of these conditions exist?

If **YES**, go to "Restore the Switching Module ODD," Subprocedure 7.2.3, to recover switching module ODD, then return to the next step.

If **NO**, continue with the next step.

11. Obtain status from Page 141 or type and enter:

OP:SYSSTAT:SM=x;

Response: **OP SYSSTAT SUMMARY LAST RECORD**
L LSM n,n: rrr

Where: rrr = Switching module off-normal status.

12. Using the response from the previous step, does the switching module have a progress marker status of:

Any Init-in-progress state?
INIT ISOL
COMM LOST
ISOLATED
STNDALONE

If **YES**, continue with the next step.

If **NO**, proceed to Step 17.

13. For the switching module: type and enter either: **923** or

INIT:SM=a,FI,PUMP;

Where: a = The switching module number.

Response: INIT SM=a LVL=FI SUMMARY EVENT = xxxxx
CALL PROCESSING DOWNTIME=x:xx:xx
CALLS LOST: STABLE=x TRANSIENT=x

14. Clear forces on MHD and allow the CU to be restored. On EAI page, type and enter: **21** and **23**.

15. Allow MHD diagnostics again and restore MHDs to duplex operation. Type and enter:

ALW:DMQ:SRC=ADP;

16. Restart diagnostics if necessary. Type and enter:

OP:DMQ;

17. If MHD diagnostics are not active or waiting, from MCC Page 111, type and enter: **30x** to restore the MHDs.

Where: x = MHD Number

Response: RST MHD x TASK y MSG STARTED
RST MHD x IN PROGRESS
(will be output every 2 minutes)
RST MHD x COMPLETED

18. Was either switching module text or switching module ODD reloaded from tape?

If **YES**, use "Off-Line Pump for Recovery of a Functional Switching Module," 235-105-250, **5ESS**® *Switch System Recovery*, to off-line pump and switch the switching module, then return to the next step.

If **NO**, continue with the next step.

19. On the EAI Page, is the **INH** indicator for **Inh Hdw Chk** or **Inh Sft Chk** backlighted?
If **YES**, type and enter: **35** and **37**
If **NO**, continue with the next step.
20. On the EAI Page, is the **Backup Root** indicator **SET**?
If **YES**, use "Recover from BROOT Configuration," Subprocedure 7.2.4, to recover root file system, and return to next step.
If **NO**, continue with next step.
21. Type and enter:
ALW:AUD=SODD,FULL;
22. Reschedule ODD Backup. Type and enter:
BKUP:ODD:EVERY=a,AT=b;
Where: a = Number of days between ODD backups
 b = Time of day in hours and minutes (for example 2330 = 11:30 p.m.)
23. **STOP. YOU HAVE COMPLETED THIS PROCEDURE.**

7.2.2 Restore Switching Module Text on Outboard MHDs

OVERVIEW

If an MHD2/MHD3 switching module text tape (/dev/vtoc1) at the same software update level as the AM text (/dev/vtoc) restored from the backup media is not available, install an older tape now and obtain a tape of the same software update level as the /no5text partition to install later.

PROCEDURE

1. Mount the tape on the tape drive.

At the MCC, type and enter: **DUMP:BKTAPE:TD="x"**

Where: x = Pathname of the tape special device file.

Response: DUMP BKTAPE TD x STARTED

For each logical volume on the tape, the following response appears:

Response: DUMP BKTAPE TD x IN PROGRESS

SESSION	VOLUME	NAME	BLOCKS	SOURCE	DATE
a	b	c	d	e	f

Where:

- a = Backup session number.
- b = Logical volume number.
- c = Logical volume name.
- d = Number of blocks for the logical volume.
- e = Source disk(s) logical volume was written from.
- f = Date logical volume was written.

After all logical volumes have been processed, the following response appears:

Response: DUMP BKTAPE TD x COMPLETED
CUMULATIVE BLOCKS a

Where: a = Cumulative number of blocks for all logical volumes.

Note the session number and volume number of the SM TEXT backup to be read into the partitions.

2. Is an STLWS available?

If **YES**, go to Step 7.

If **NO**, continue with the next step.

3. At the MCC, type and enter: **194**

Response:

Depress PF3 key twice to reconnect to the SCREEN process if the Command Message Key (PF3) has been used during this procedure.

What is the desired command?

- | | |
|---------------|------------|
| o) ODBE | c) CNIDBOC |
| a) ACCED | r) RTAG |
| u) UNIX SHELL | Q) TO QUIT |

Please enter o,a,u,c, r, or Q:

Character mappings
\\:, \\1, \\s, \\8, \\-, \\a, \\/, \\|, \\
; , ! , \$, & , - , @ , ? , \ ,

4. Enter the *UNIX*¹ mode. Type and enter: **u**

5. Invoke rlddft. Type and enter: **/usr/bin/rlddft**

Note: When using the MCC, the screens displayed by rlddft will not paint as it does when used with an STLWS. Some lines in the screens which follow may not be displayed. Commands are entered in the upper left corner and displayed next to the rlddft prompt after pressing the **RETURN** key.

6. Go to Step 9.

7. Clear the screen with a **120** poke.

8. The tape to be mounted is the switching module text tape for MHD2/MHD3 (/dev/vtoc1) with the same software update level marking on the tape label as the software update level of the AM text that was just booted.

Type and enter: **RCV:MENU:RDLDFI;**

Response:

Please enter the tape drive number.
Please enter the number '0' for tape drive MT0 or
the number '1' for tape drive MT1, etc.:

9. At the RDLDFI display prompt, type and enter: **0**

Response:

Please enter the letter 'x' for SM TEXT or
the letter 's' for SM ODD:

10. At the RDLDFI display prompt, type and enter: **x** to load SM Text.

Response:

What tape volume format is to be used?
Please enter 'm' for Multi-volume format or
's' for Single-volume format:

1. Registered trademark in the United States and other countries, licensed exclusively through X/Open Company, Limited

11. At the RDLDFt display prompt, type and enter: **m**

Response:

```
Please enter session number:
```

12. At the RDLDFt display prompt, type and enter: **the session number [1-9]** from Step 1.

Response:

```
Please enter volume number:
```

13. At the RDLDFt display prompt, enter **3** for the volume number for SM Text.

Response:

```
What tape density is to be used?  
Please enter the number '8' for low density or  
the number '0' for high density:
```

14. At the RDLDFt display prompt, type and enter: **8** for the low tape density identifier.

15. Once the tape density identifier has been selected, the following statement will be displayed. Observe the statement, then continue with next step.

```
RDLDFt: SM TEXT tape sequence chosen for /dev/vtocl on /dev/mtxx  
RDLDFt: Please mount the first backup tape on the tape drive  
and insure that the ONLINE button is ON.  
Please enter 'go' after the tape is mounted:
```

Note: If this statement is not received within a few seconds, monitor ROP for REPT FMGR UMount FAILED output message and **seek technical assistance** to identify process that is blocking UNMount of SM text file system.

16. Make sure the switching module text tape is mounted, ensure that the tape drive **ONLINE** button is **ON**, and then type and enter: **: go**

Note: As the tape is being loaded to disk, a tape load forward progressing dot will appear on the terminal approximately every 30 seconds. Once the tape load has completed, the following message will be printed.

Response: RDLDFt COMPLETED
RCV MENU RDLDFt COMPLETED

17. Was the RDLDFt COMPLETED message received?

If **YES**, switching module text has been loaded. Continue with the next step.

If **NO**, **seek technical assistance**.

18. Was rdlldft invoked from the MCC?

If **YES**, exit from *UNIX* shell, type and enter: **q** and exit from the MCC Page 194, type and enter: **q**

If **NO**, continue with the next step.

19. Did the switching module text backup tape read into the text partitions successfully?

If **YES**, **STOP. YOU HAVE COMPLETED THIS PROCEDURE.**

If **NO**, **seek technical assistance.**

7.2.3 Restore the Switching Module ODD

OVERVIEW

The following steps will install the switching module ODD disk image from backup switching module ODD tapes.

PROCEDURE

1. Mount the tape on the tape drive.

At the MCC, type and enter: **DUMP:BKTAPE:TD="x"**

Where: x = Pathname of the tape special device file.

Response: DUMP BKTAPE TD x STARTED

For each logical volume on the tape, the following response appears:

Response: DUMP BKTAPE TD x IN PROGRESS

SESSION	VOLUME	NAME	BLOCKS	SOURCE	DATE
a	b	c	d	e	f

Where:

- a = Backup session number.
- b = Logical volume number.
- c = Logical volume name.
- d = Number of blocks for the logical volume.
- e = Source disk(s) logical volume was written from.
- f = Date logical volume was written.

After all logical volumes have been processed, the following response appears:

Response: DUMP BKTAPE TD x COMPLETED
CUMULATIVE BLOCKS a

Where: a = Cumulative number of blocks for all logical volumes.

Note the session number and volume number of the SM TEXT backup to be read into the partitions.

2. Is an STLWS available?

If **YES**, go to Step 7.

If **NO**, continue with the next step.

3. At the MCC, type and enter: **194**

Response:

Depress PF3 key twice to reconnect to the SCREEN process if the Command Message Key (PF3) has been used during this procedure.

What is the desired command?

o) ODBE	c) CNIDBOC
a) ACCED	r) RTAG
u) UNIX SHELL	Q) TO QUIT

Please enter o,a,u,c, r, or Q:

Character mappings
\\:, \\1, \\s, \\8, \\-, \\a, \\/, \\\\, \\
;, !, \$, &, -, @, ?, \\,

4. Enter *UNIX*¹ shell. Type and enter: **u**
5. Invoke rlddft. Type and enter: **/usr/bin/rlddft**

Note: When using the MCC, the screens displayed by rlddft will not paint as it does when used with an STLWS. Some lines in the screens which follow may not be displayed. Commands are entered in the upper left corner and displayed next to the rlddft prompt after pressing the **RETURN** key.

6. Go to Step **9**.
7. Clear the screen, type and enter: **120**
8. At the command prompt, start the load disk from tape program.

The Volume Table Of Contents (VTOC) to be selected must be the same as the /dev/vtocx on each of the switching module ODD backup tape labels. The switching module ODD tape must have been made in the same software release backup session as the AM ODD tape which was used in the recovery.

Type and enter: **RCV:MENU:RDLDFI;**

Response:

```
Please enter the tape drive number.  
Please enter the number '0' for tape drive MT0 or  
the number '1' for tape drive MT1, etc.:
```

9. At the RDLDFI display prompt, type and enter: **0**

Response:

```
Please enter the letter 'x' for SM TEXT or  
the letter 's' for SM ODD:
```

10. At the RDLDFI display prompt, type and enter: **s** to load SM ODD.

Response:

```
What tape volume format is to be used?  
Please enter 'm' for Multi-volume format or  
's' for Single-volume format:
```

11. At the RDLDFI display prompt, type and enter: **m**

Response:

```
Please enter session number:
```

12. At the RDLDFI display prompt, type and enter: **the session number [1-9]** from Step 1.

Response:

1. Registered trademark in the United States and other countries, licensed exclusively through X/Open Company, Limited

Please enter volume number:

13. At the RDLDF'T display prompt, type and enter: **the volume number [4-9]** from Step 1.

Response:

What tape density is to be used?
Please enter the number '8' for low density or
the number '0' for high density:

14. At the RDLDF'T display prompt, type and enter: **8** for the low tape density identifier.

Response:

What vtoc is to be used?
Please enter ONLY one number for the below choices:

1	for /dev/vtoc1
2	for /dev/vtoc2
3	for /dev/vtoc3
4	for /dev/vtoc4
5	for /dev/vtoc5
6	for /dev/vtoc6:

15. At the RDLDF'T display prompt, type and enter: **1**

16. Once the VTOC has been selected, the following statement will be displayed. Observe the statement, then continue with the next step. If this statement is not received within a few seconds, then monitor ROP for REPT FMGR UMount FAILED output message and **seek technical assistance** to identify process that is blocking UNMount of SM ODD file system.

Response:

RDLDF'T: SM ODD tape sequence chosen for /dev/vtoc1 on /dev/mtxx
RDLDF'T: Please mount the first backup tape on the tape drive
and insure that the ONLINE button is ON.
Please enter 'go' after the tape is mounted:

17. Make sure the switching module ODD backup tape is mounted, ensure that the tape drive **ONLINE** button is **ON**, and then enter the following: **go**

Note: As the tape is being loaded to disk, a tape load forward progression dot will appear on the terminal every 30 seconds. Once the tape load has completed, the following messages will be printed:

RDLDF'T COMPLETED
RCV MENU RDLDF'T COMPLETED

18. Was the RDLDF'T COMPLETED message received?

If **YES**, the tape load using the VTOC selected in Step 15 has completed; continue with the next step.

If **NO**, **seek technical assistance**.

19. Was rlddft invoked from the MCC?

If **YES**, exit from *UNIX* shell, type and enter: **q** and exit from the MCC Page 194, type and enter: **q**

If **NO**, continue with the next step.

20. Did the switching module ODD backup tape read into the ODD partitions successfully?

If **YES**, continue with the next step.

If **NO**, **seek technical assistance**.

21. Type and enter:

EXC:ENVIR:UPROC,FN="/no5text/bkup/clrlg";

Note: The Recent Change (RC) and Customer-Originated Recent Change (CORC) log files in the system are no longer consistent with the ODD just read in from tape. The AM Backout indicator should be returned to normal. This is accomplished by first clearing the RC and CORC recent change log files (AM and switching module) and then clearing the AM recent change backout indicator.

Response: EXC ENVIR UPROC /no5text/bkup/clrlg STOPPED rm:cni directory
OR
EXC ENVIR UPROC STOPPED (If log files do not exist) rm *
non-existent

22. Type and enter:

STP:EXC:ANY,FN="/no5text/rcv/lglg",UCL;

Response: REPT ULARP ATTEMPTING TO RESTART LGLOG xx STOP EXC
ANY COMPLETED

23. Clear backup schedule. Type and enter:

CLR:ODDBKUP;

Response: **CLR ODDBKUP COMPLETED**

24. Type and enter:

EXC:ODDRCVY=SKIPLOG,AM;

Warning: *Inappropriate use of this message may interrupt or degrade application service. Refer to 235-600-700/750, Input/Output Messages Manual.*

Response: EXC ODDRCVY=SKIPLOG AM COMPLETED

25. Type and enter: **521** to clear RC BKOUT box on MCC Page 110.

Response: RC BKOUT box clears.

Note: The AM is currently running on a different version of the ODD than the switching module. To correct this situation, the switching module must be initialized.

26. **STOP. YOU HAVE COMPLETED THIS PROCEDURE.** Return to "Post AM Recovery Cleanup," Subprocedure 7.2.1.

7.2.4 Recover from BROOT Configuration

OVERVIEW

Warning: *The AM is currently running on the backup root configuration. Therefore, ECD recent changes should not be made to the root or rootdmly copies of the ECD/SG database until this procedure is completed.*

Note: The following steps should be performed during a low-traffic period. The objective is to have the AM running on the root configuration. This is accomplished by copying the backup root partitions to the root partitions and booting the AM.

PROCEDURE

1. Type and enter:

```
DUMP:FILE:ALL,FN="/no5text/bkup/prim.ptn";
```

```
Response: DUMP FILE ALL COMPLETE
          Contents of /no5text/bkup/prim.ptn printed:
          /dev/root
          /dev/db
          /dev/etc
          /dev/boot
```

2. Type and enter:

```
DUMP:FILE:ALL,FN="/no5text/bkup/bkup.ptn";
```

```
Response: DUMP FILE ALL COMPLETE
          Contents of /no5text/bkup/bkup.ptn printed:
          /dev/broot
          /dev/bdb
          /dev/betc
          /dev/boot
```

3. Do the contents of `/no5text/bkup/prim.ptn` and `/no5text/bkup/bkup.ptn` agree with the responses listed in Steps 1 and 2?

If **YES**, continue with the next step.

If **NO**, **STOP. DO NOT CONTINUE. Seek technical assistance.**

4. Both MHD0 and MHD1 must be active at this point. Type and enter:

```
COPY:PTN:ALL,SRC="/no5text/bkup/bkup.ptn",
DEST="/no5text/bkup/prim.ptn";
```

```
Response: RMV MHD x TASK y MSG STARTED
          RMV MHD x COMPLETED
          RST MHD x TASK y MSG STARTED
          RST MHD x IN PROGRESS (is output every 2 minutes)
          RST MHD x COMPLETED
          COPY PTN FILE COMPLETED
          xxxx BLOCKS COPIED (repeated 4 times)
```

5. On EAI page, type and enter: **31** to clear the backup configuration.
6. On EAI page, type and enter: **53** to boot the AM.
7. Is the response to the previous step **boot? (y/n)**?
If **YES**, type and enter **y** and continue.

- If **NO**, continue with the next step.
8. Did the initialization complete?
If **YES**, continue with the next step.
If **NO**, analyze the initialization failure.
 9. **STOP. YOU HAVE COMPLETED THIS PROCEDURE.** Return to “Post AM Recovery Cleanup,” Subprocedure 7.2.1

7.3 Establish Communication with an Isolated Switching Module

OVERVIEW

This procedure is used to recover an isolated switching module. The loss of communication can be indicated on MCC display Page **1800,x** by one of the following status indications: COMM LOST, INIT PEND, STNDALONE, or ISOLATED. To simplify this procedure, all of these states will be referred to as COMM LOST.

It should be noted that MCC display Page **1800,x** is partially updated from the switching module. When AW/switching module communication is lost, this page will display the AW's stored information about the switching module. Therefore, not all indicators on the page will reflect the true status of the unit when the switching module has lost communication. When AW/switching module communication is restored, the page will be updated to reflect the current status of the unit. Following each recovery action specified by this procedure, pause briefly to allow the switching module to reestablish communication (if possible) and update the MCC display.

PROCEDURE

1. Perform a visual check to ensure that the *Ethernet*¹ cabling between the switching module and the Administrative Workstation is intact.
2. On MCC Page 111/112, is the communication link to the switching module broken?
If **YES**, continue with Step 3.
If **NO**, **STOP. YOU HAVE COMPLETED THIS PROCEDURE**
3. At the MCC Page 1800,x, type and enter: **403** to manually isolate the switching module.
Response: ISOLATE? (y/n).
Type and enter: **y**
Response: SET present in box 03.
4. At the MCC Page 1800,x, type and enter: **503** to clear the manual isolation. Wait 3 minutes.
Response: SET cleared in box 03.
5. On the MCC Page 111/112, is the communication link to the switching module broken?
If **YES**, continue with Step 6.
If **NO**, **STOP. YOU HAVE COMPLETED THIS PROCEDURE.**
6. At the MCC Page 1800,x, type and enter: **ORD:CPI=x,CMD=CLR,UCL;** to clear forces on the switching module.
Where: x = The switching module number.

1. Registered trademark of Xerox Corporation.

Perform this command even if the MCC Page 1800,x does not indicate forces are there. There can be two different responses:

Response: ORD CPI x CMD CLR COMPLETED
OR
ORD CPI x CMD CLR NOT COMPLETED
UNIT RESULT x STATUS UNKNOWN

Where: x = The switching module number.

7. At the MCC Page 1800,x, type and enter: **705,UCL** to allow the sanity timer. Perform this command even if the MCC display page 1800,X does not indicate the sanity timer has been inhibited. There can be two different responses to this command.

Response: ORD CPI x CMD ALW COMPLETED
OR
ORD CPI x CMD ALW NOT COMPLETED
UNIT RESULT
x STATUS UNKNOWN

Where: x = The switching module number.

8. On the MCC Page 111/112, is the communication link to the switching module broken?

If **YES**, continue with Step 9.

If **NO**, **STOP. YOU HAVE COMPLETED THIS PROCEDURE.**

9. Halt the Administrative Workstation by executing Procedure 4.2.
10. Restore the Administrative Workstation by executing Procedure 4.3.
11. Restore MHDs 1 and 3 by poking 301 and 303 on the MCC 111/112 page.
12. On the MCC Page 111/112, is the communication link to the switching module broken?

Warning: Steps 13-16 will stop all call processing and will drop all stable calls! Do you wish to proceed?

13. Power down MCTSI 0 using only the **OFF** button located on MCTSI 0s Control and Display Pack. **DO NOT USE the MOR SWITCH.**
14. At MCTSI 0 control and display pack, power up MCTSI 0.
15. Power down MCTSI 1 using only the **OFF** button located on MCTSI 1s Control and Display Pack. **DO NOT USE the MOR SWITCH.**
16. At MCTSI 1 control and display pack, power up MCTSI 1.
17. On the MCC Page 111/112, is the communication link to the switching module no longer broken?

If **YES**, **STOP. YOU HAVE COMPLETED THIS PROCEDURE.**

If **NO**, **seek technical assistance.**

Distinctive Remote Module (DRM)

CONTENTS		PAGE
8.	GROWTH AND DEGROWTH	8 - 1
8.1	Perform Virtual TTY Growth	8.1-1
8.2	Perform Virtual TTY Controller Growth	8.2-1
8.3	Perform STLWS Growth	8.3-1
8.4	Perform RC/V Terminal Growth	8.4-1
8.5	Grow MCC Dial-Up Modem Access	8.5-1
8.6	Grow Remote <i>Sun</i> Console Dial-Up Modem Access	8.6-1
8.7	Perform SCANS Data Link Growth	8.7-1
8.8	Perform AMA Data Link Growth	8.8-1
8.9	Perform SCC Data Link Growth	8.9-1
8.10	Perform ConnectVu (ATPRC) Data Link Growth	8.10-1
8.11	Perform TDMS/EADAS Data Link Growth	8 . 1 1 - 1
8.11.1	Grow in TDMS/EADAS Data Link in ECD	8.11.1-1
8.11.2	Update RC/V 8.1 for TDMS/EADAS Data Link	8.11.2-1
8.11.3	Connect Hardware for TDMS/EADAS Data Link	8.11.3-1
8.11.4	Define TDMS/EADAS Port on TDMS System	8.11.4-1
8.11.5	Initialize TDMS/EADAS Processes	8.11.5-1
8.11.6	Restore TDMS/EADAS Data Link to Service	8.11.6-1
8.11.7	Verify Operation of TDMS/EADAS Data Link	8.11.7-1
8.11.8	Backup Office Dependent Data	8.11.8-1
8.12	Perform RMAS Data Link Growth	8.12-1
8.12.1	Grow in RMAS Data Link in ECD.	8.12.1-1
8.12.2	Connect Hardware for RMAS Data Link	8.12.2-1
8.12.3	Configure RMAS RC Access	8.12.3-1

8.12.4	Verify Operation of RMAS Data Link	8.12.4-1
8.13	Perform Traffic Printer Growth	8.13-1
8.14	Perform Office Record Printer Growth	8.14-1
8.14.1	Update the Office Record Printer Baud Rate	8.14.1-1
8.15	Perform Virtual TTY Controller Degrowth	8.15-1
8.16	Perform Virtual TTY Degrowth.	8.16-1
8.17	Perform STLWS Degrowth	8.17-1
8.18	Perform RC/V Terminal Degrowth	8.18-1
8.19	Perform SCC Data Link Degrowth	8.19-1
8.20	Perform Traffic Printer Degrowth	8.20-1
8.21	Perform Office Record Printer Degrowth	8.21-1

LIST OF FIGURES

Figure 8.3-1	— STLWS Installation (<i>Netra t 1120</i>)	8.3-5
Figure 8.3-2	— STLWS Installation (<i>Netra 20</i>)	8.3-5
Figure 8.3-3	— STLWS Installation (<i>Netra 240</i>)	8.3-6
Figure 8.4-1	— Recent Change Terminal Installation (<i>Netra t 1120</i>)	8.4-3
Figure 8.4-2	— Recent Change Terminal Installation (<i>Netra 20</i>)	8.4-3
Figure 8.4-3	— Recent Change Terminal Installation (<i>Netra 240</i>)	8.4-4
Figure 8.5-1	— Dial-Up MCC Hardware Connections	8.5-4
Figure 8.6-1	— Dial-Up <i>Sun</i> Console Hardware Connections	8.6-4
Figure 8.7-1	— SCANS Data Link Hardware Installation (<i>Netra t 1120</i>)	8.7-2
Figure 8.7-2	— SCANS Data Link Hardware Installation (<i>Netra 20</i>).	8.7-3
Figure 8.7-3	— SCANS Data Link Hardware Installation (<i>Netra 240</i>)	8.7-4
Figure 8.8-1	— AMA Data Link Hardware Connection (<i>Netra t 1120</i>)	8.8-3
Figure 8.8-2	— AMA Data Link Hardware Installation (<i>Netra 20</i>).	8.8-3
Figure 8.8-3	— AMA Data Link Hardware Installation (<i>Netra 240</i>)	8.8-4
Figure 8.9-1	— SCC Data Link Hardware Connection (<i>Netra t 1120</i>)	8.9-4

Figure 8.9-2 — SCC Data Link Hardware Connection (<i>Netra</i> 20).	8.9-4
Figure 8.9-3 — SCC Data Link Hardware Connection (<i>Netra</i> 240)	8.9-5
Figure 8.10-1 — ATPRC Data Link Hardware Connection (<i>Netra</i> t 1120).	8.10-2
Figure 8.10-2 — ATPRC Data Link Hardware Connection (<i>Netra</i> 20)	8.10-3
Figure 8.10-3 — ATPRC Data Link Hardware Connection (<i>Netra</i> 240).	8.10-4
Figure 8.11.3-1 — DIP Shunt Settings for IC456A-R2	8.11.3-1
Figure 8.11.3-2 — Wiring Diagram for TDMS/EADAS or RMAS Data Link (<i>Netra</i> t 1120)	8.11.3-2
Figure 8.11.3-3 — Wiring Diagram for TDMS/EADAS or RMAS Data Link (<i>Netra</i> 20).	8.11.3-2
Figure 8.11.3-4 — Wiring Diagram for TDMS/EADAS or RMAS Data Link (<i>Netra</i> 240)	8.11.3-3
Figure 8.13-1 — Traffic Printer Installation (<i>Netra</i> t 1120)	8.13-3
Figure 8.13-2 — Traffic Printer Installation (<i>Netra</i> 20)	8.13-3
Figure 8.13-3 — Traffic Printer Installation (<i>Netra</i> 240)	8.13-4
Figure 8.14-1 — Office Record Printer Installation (<i>Netra</i> t 1120)	8.14-3
Figure 8.14-2 — Office Record Printer Installation (<i>Netra</i> 20)	8.14-3
Figure 8.14-3 — Office Record Printer Installation (<i>Netra</i> 240)	8.14-4

LIST OF TABLES

Table 8.3-1 — <i>Netra</i> ^b t 1120 and <i>Netra</i> 20 Terminal Locations	8.3-3
Table 8.3-2 — <i>Netra</i> 240 Terminal Locations	8.3-4
Table 8.5-1 — Dial-Up MCC Hardware Requirements	8.5-1
Table 8.6-1 — Dial-Up <i>Sun</i> Console Hardware Requirements	8.6-1

See note(s) at end of table.

8. GROWTH AND DEGROWTH

Overview

Note: Although procedure steps involving software commands can be performed via the ASM (via an OA&M cut-through), someone must be present at the DRM office to perform any hardware portions.

The term growth, relative to switch hardware, refers to the addition of equipment units to the office and/or the expansion of equipment units already present. The term degrowth refers to the removal of equipment units and the removal of packs or circuits from an equipment unit. All of the equipment which may be grown must also be considered for degrowth. The procedures in this chapter refer to hardware in the DRM office.

For more information on switch growth and degrowth, see 235-105-231, **5ESS**[®] *Switch Hardware Change Procedures - Growth* and 235-105-331, **5ESS** *Switch Hardware Change Procedures - Degrowth*.

See note(s) at end of table.

8.1 Perform Virtual TTY Growth

OVERVIEW

This procedure is used to grow a virtual TTY. For more information, see 235-600-315, **5ESS**[®] *Switch ECD/SG Database Manual*.

PROCEDURE

1. Enter *UNIX*¹ RTR Recent Change and Verify.
 - (a) Is MCC or STLWS terminal to be used?
For MCC, proceed to Step **b**.
For STLWS proceed to Step **i**.
 - (b) At MCC, ensure terminal is in command mode.
 - (c) At MCC, do Steps **d** through **h**.
 - (d) Type and enter: **199**
Response: RCV PARAMETER INFO page displayed with cursor at 1.
database_name
 - (e) Type and enter: **incore**
Response: 2. review only
 - (f) Type and enter: **n**
Response: 3. journaling
 - (g) Type and enter: *****
Response: RCV INITIALIZATION IN PROGRESS message displayed.
UNIX RTR RCV (ODIN) - Data Entry page displayed.
 - (h) You have completed Enter *UNIX* RTR Recent Change and Verify, proceed to Step **2**.
 - (i) At STLWS terminal, type and enter: **RCV:MENU:DATA,RCVECD**
Response: RCV ECD PARAMETER INFO page displayed with cursor at 1.
database_name
 - (j) Type and enter: **incore**
Response: 2. review only
 - (k) Type and enter: **n**
Response: 3. journaling
 - (l) Type and enter: *****
Response: RCV INITIALIZATION IN PROGRESS message displayed.
UNIX RTR RCV (ODIN) - Data Entry page displayed. Cursor
at Enter Form Name:
2. Enter high-level forms.

1. Registered trademark in the United States and other countries, licensed exclusively through X/Open Company, Limited.
See note(s) at end of table.

- (a) Type and enter: **toggle**

Response: Will take you to the high-level forms.

3. Insert virtual TTY data.

Note: An ! may be entered any time prompted to abort the form and return to the state when the form was started.

- (a) Type and enter: **v ttyadd**

Response: v ttyadd form displayed. Cursor at 1.v tty_name:

- (b) Type and enter the following data:

1.v tty_name: enter TTY name (see the following **TTY NAMES** list)

2.shared^a: enter y or n

3.port^b: enter 0, 1, 2, or 3

4.v ttyc_number enter VTTYC controller number

Note(s):

a. VTTY7, VTTY23, VTTY43, and VTTY45 will always be inserted as non-shared VTTYs.

b. To determine the port availability on VTTYC, at a selected terminal, type and enter the command: **OP:CFGSTAT:VIOP;**

TTY NAMES

VTTY0 or tty!
VTTY2 or tty#
VTTY7 or ttyh or VTRAFFPRT
VTTY9 or ttyj
VTTY10 or ttyk
VTTY11 or ttyl
VTTY12 or ttym
VTTY13 or ttyn
VTTY14 or ttyo
VTTY22 or ttyw
VTTY23 or tty8 or VBALANCE
VTTY28 or ttyC
VTTY29 or ttyD
VTTY30 or ttyE
VTTY31 or ttyF
VTTY32 or ttyG
VTTY33 or ttyH
VTTY34 or ttyI
VTTY43 or ttyR or VOFFRECPRT
VTTY45 or ttyT or VCOT
VTTY50 or ttyY
VTTY56 or tty%
VTTY57 or tty'
VTTY58 or tty&
VTTY59 or tty(
VTTY60 or tty_
VTTY61 or tty[
VTTY62 or ttyJ
VTTY63 or ttyV
VTTY64 or ttyW
VTTY65 or ttyX
VTTY66 or ttyZ

- (c) Type and enter: **i**
Note: An error message will be displayed if you have a physical TTY with the same TTY letter as the VTTY being grown. Select another VTTY or degrow the physical TTY. Refer to 235-105-331, **5ESS Switch Hardware Change Procedures — Degrowth** or 235-600-315, **5ESS Switch ECD/SG Database Manual**.
 - (d) First prompt: Remove VTTYC/VTTY x from service. Enter CARRIAGE RETURN to continue. At DRM MCC terminal, type and enter command:
RMV:[VTTYC,VTTY]=x
Where: x = VTTYC/VTTY number of the previous logical unit.
Response: RMV [VTTYC,VTTY] x COMPLETED
 - (e) Second prompt: Restore VTTYC/VTTY x to service. Enter CARRIAGE RETURN to continue. At DRM MCC terminal, type and enter command:
RST:[VTTYC,VTTY]=x
Where: x = VTTYC/VTTY number of the previous logical unit.
Response: RST [VTTYC,VTTY] x COMPLETED
 - (f) Third prompt: Restore VTTY x to service. Enter CARRIAGE RETURN to continue. At DRM MCC terminal, type and enter command: **RST:VTTY=x**
Where: x = appropriate VTTY number.
Response: RST VTTY x COMPLETED
 - (g) The low-level forms will now be added automatically.
Response: FORM INSERTED
4. Exit high-level forms.
- (a) Type and enter: **<**
Response: Exit the vttyadd form UNIX RTR RCV (ODIN) - Data Entry page displayed. Cursor at Enter Form Name:
 - (b) Type and enter: **toggle**
Response: Will take you to the low-level forms.
5. Backup Incore ECD to disk.
- (a) Type and enter: **activate**
Response: Activate form displayed with cursor at 1.copy_inc_to_disk:YES
 - (b) Enter CARRIAGE RETURN
Response: ODIN will request the action desired.
 - (c) Type and enter: **e**
Response: ODIN returns to the UNIX RTR (ODIN) - Data Entry page.
 - (d) Type and enter: **<**
Response: RCV ECD COMPLETED
6. Change Security (optional).

- (a) At DRM MCC, type and enter:
SET:RCACCESS,TTY="xxxx",ACCESS=a;
- Where: a = Value obtained from the 235-600-700, *Input Messages Manual*
xxxx = TTY name from **TTY NAMES** list in Step **3b** (for example, if growing VTTY12, xxxx = ttym)
- (b) Check the access code, type and enter: **OP:RCACCESS,TTY="xxxx"**
- Where: xxxx = TTY name from **TTY NAMES** list in Step **3b** (for example, if growing VTTY12, xxxx = ttym)
- Response: The access code will be returned in hexadecimal.
7. Backup primary disk.
- It is recommended that Primary Disk Backup be performed and a shelf copy of the disks made.
8. **STOP. YOU HAVE COMPLETED THIS PROCEDURE.**

8.2 Perform Virtual TTY Controller Growth

OVERVIEW

This procedure is used to grow a virtual TTY controller. For more information, see 235-600-315, **5ESS**[®] *Switch ECD/SG Database Manual*.

PROCEDURE

1. Enter *UNIX*¹ RTR Recent Change and Verify.
 - (a) Is MCC or STLWS terminal to be used?
For MCC, proceed to Step **b**.
For STLWS proceed to Step **i**.
 - (b) At MCC, ensure terminal is in command mode.
 - (c) At MCC, do Steps **d** through **h**.
 - (d) Type and enter: **199**
Response: RCV PARAMETER INFO page displayed with cursor at 1.
database_name
 - (e) Type and enter: **incore**
Response: 2. review only
 - (f) Type and enter: **n**
Response: 3. journaling
 - (g) Type and enter: *****
Response: RCV INITIALIZATION IN PROGRESS message displayed.
UNIX RTR RCV (ODIN) - Data Entry page displayed.
 - (h) You have completed Enter *UNIX* RTR Recent Change and Verify, proceed to Step **2**.
 - (i) At STLWS terminal, type and enter: **RCV:MENU:DATA,RCVECD**
Response: RCV ECD PARAMETER INFO page displayed with cursor at 1.
database_name
 - (j) Type and enter: **incore**
Response: 2. review only
 - (k) Type and enter: **n**
Response: 3. journaling
 - (l) Type and enter: *****
Response: RCV INITIALIZATION IN PROGRESS message displayed.
UNIX RTR RCV (ODIN) - Data Entry page displayed. Cursor
at Enter Form Name:
2. Enter high-level forms.

1. Registered trademark in the United States and other countries, licensed exclusively through X/Open Company, Limited.

- (a) Type and enter: **toggle**

Response: Will take you to the high-level forms.

- 3. Insert virtual TTY controller data.

Note: An ! may be entered any time prompted to abort the form and return to the state when the form was started.

- (a) Type and enter: **vttycadd**

Response: vttycadd form displayed. Cursor at 1. ttyc_name:

- (b) Type and enter the following data:

1.vttyc_name: enter VTTYC name (VTTYC0 - VTTYC10,
VTTYC30 - VTTYC34)

2.slot^a: enter 0 - 15 to select a slot on VIOP 0

3.VIOP_number enter 0 as specified

Note(s):

- a. To determine the slot availability on VIOP 0, at a selected terminal, type and enter the command: **OP:CFGSTAT:VIOP;**.

- (c) Type and enter: **i**

- (d) First prompt: Remove VTTYC x from service. Enter CARRIAGE RETURN to continue. At DRM MCC terminal, type and enter command: **RMV:VTTYC=x**

Where: x = VTTYC number of the previous logical unit.

Response: **RMV VTTYC x COMPLETED**

- (e) Second prompt: Restore VTTYC x to service. Enter CARRIAGE RETURN to continue. At DRM MCC terminal, type and enter command: **RST:VTTYC=x**

Where: x = VTTYC number of the previous logical unit.

Response: **RST VTTYC x COMPLETED**

Note: During the growth of the first VTTYC, the VIOP 0 low-level forms will automatically be added and there will be no prompts to remove/restore previous logical units. There will be a prompt to restore the VIOP:

Prompt: Restore VIOP 0 to service. Enter CARRIAGE RETURN to continue. At DRM MCC terminal, type and enter command: **RST:VIOP=0**

Response: **RST VIOP 0 COMPLETED**

- (f) The low-level forms will now be added automatically.

Response: **FORM INSERTED**

- 4. Exit high-level forms.

- (a) Type and enter: **<**

Response: Exit the vttycadd form UNIX RTR RCV (ODIN) - Data Entry page displayed. Cursor at Enter Form Name:

- (b) Type and enter: **toggle**

Response: Will take you to the low-level forms.

5. Backup Incore ECD to disk.
 - (a) Type and enter: **activate**
Response: Activate form displayed with cursor at 1.copy_inc_to_disk:YES
 - (b) Enter CARRIAGE RETURN
Response: ODIN will request the action desired.
 - (c) Type and enter: **e**
Response: ODIN returns to the UNIX RTR (ODIN) - Data Entry page.
 - (d) Type and enter: **<**
Response: RCV ECD COMPLETED
6. Restore VTTYC x to service.

Note: If the Perform Virtual TTY Growth procedure is planned to be executed concurrently, Steps **6** and **7** can be omitted.

 - (a) At DRM MCC, type and enter: **RST:VTTYC=x**
Where: x = appropriate VTTYC number.
Response: RST VTTYC x COMPLETED
7. Backup primary disk.

It is recommended that Primary Disk Backup be performed and a shelf copy of the disks made.
8. **STOP. YOU HAVE COMPLETED THIS PROCEDURE.**

8.3 Perform STLWS Growth

PROCEDURE

1. Enter *UNIX*¹ RTR Recent Change and Verify.
 - (a) Is MCC or STLWS terminal to be used?
For MCC, proceed to Step **b**.
For STLWS proceed to Step **i**.
 - (b) At MCC, ensure terminal is in command mode.
 - (c) At MCC, do Steps **d** through **h**.
 - (d) Type and enter: **199**
Response: RCV PARAMETER INFO page displayed with cursor at 1.
database_name
 - (e) Type and enter: **incore**
Response: 2. review only
 - (f) Type and enter: **n**
Response: 3. journaling
 - (g) Type and enter: *****
Response: RCV INITIALIZATION IN PROGRESS message displayed.
UNIX RTR RCV (ODIN) - Data Entry page displayed.
 - (h) You have completed Enter *UNIX* RTR Recent Change and Verify, proceed to Step **2**.
 - (i) At STLWS terminal, type and enter: **RCV:MENU:DATA,RCVECD**
Response: RCV ECD PARAMETER INFO page displayed with cursor at 1.
database_name
 - (j) Type and enter: **incore**
Response: 2. review only
 - (k) Type and enter: **n**
Response: 3. journaling
 - (l) Type and enter: *****
Response: RCV INITIALIZATION IN PROGRESS message displayed.
UNIX RTR RCV (ODIN) - Data Entry page displayed. Cursor
at Enter Form Name:
2. Enter high-level forms.
 - (a) Type and enter: **toggle**
Response: Will take you to the high-level forms.
3. Insert TTY data.

1. Registered trademark in the United States and other countries, licensed exclusively through X/Open Company, Limited.

Note: An ! may be entered any time prompted to abort the form and return to the state when the form was started.

(a) Type and enter: **ttyadd**

Response: ttyadd form displayed. Cursor at 1.tty_name:

Note: Fields not specified receive the default value by entering a CARRIAGE RETURN.

(b) Type and enter the following data:

1. tty_name^a: enter TTY terminal name (TTY9-TTY14, TTY28-TTY34, or TTY50)
2. baud_rate: enter (as specified or CARRIAGE RETURN)
3. login_term: enter (as specified or CARRIAGE RETURN)
4. auth_chk: enter (as specified or CARRIAGE RETURN)
5. term_type: enter (as specified or CARRIAGE RETURN)
6. line_mode: enter (as specified or CARRIAGE RETURN)
7. port: enter 2 or 3 for TTYC port (see Tables 8.3-1 and 8.3-2)
8. ttyc_number: enter TTYC number base on SAI port (see Tables 8.3-1 and 8.3-2)
9. plu_unit_name: enter CARRIAGE RETURN
10. plu_unit_number: enter CARRIAGE RETURN

Note(s):

- a. tty_name must be entered in all capital letters.

Note: Entering **STLWS** will choose the first available STLWS type terminal and grow it automatically.

Table 8.3-1 — *Netra*^a t 1120 and *Netra* 20 Terminal Locations

SAI No.	AW PCI SLOT No.	SAI PORT	TTYC PORT	TTYC No.
0	2	2	2	11
0	2	3	3	11
0	2	4	2	12
0	2	5	3	12
0	2	6	2	13
0	2	7	3	13
1	1	0	2	14
1	1	1	3	14
1	1	2	2	15
1	1	3	3	15
1	1	4	2	16
1	1	5	3	16
1	1	6	2	17
1	1	7	3	17

Table 8.3-2 — *Netra* 240 Terminal Locations

SAI No.	AW PCI SLOT No.	SAI PORT	TTYC PORT	TTYC No.
0	1	2	2	11
0	1	3	3	11
0	1	4	2	12
0	1	5	3	12
0	1	6	2	13
0	1	7	3	13
1	0	0	2	14
1	0	1	3	14
1	0	2	2	15
1	0	3	3	15
1	0	4	2	16
1	0	5	3	16
1	0	6 ^a	NA	NA
1	0	7 ^b	NA	NA

Note(s):

- a. SAI 1 Port 6 is reserved for the MTTY on a *Netra* 240.
- b. SAI 1 Port 7 is reserved for the ROP on a *Netra* 240.

(c) Type and enter: i

Note: When growing a TTY terminal a defensive check failure message REPT CONFIG FAULT Assert = 412 may be received. This failure message may be ignored.

4. Install the STLWS to the SAI port corresponding to the TTYC port and TTYC number chosen in Tables 8.3-1 and 8.3-2 (see Figure 8.3-1 , 8.3-2) and 8.3-3.

(a) Enter CARRIAGE RETURN

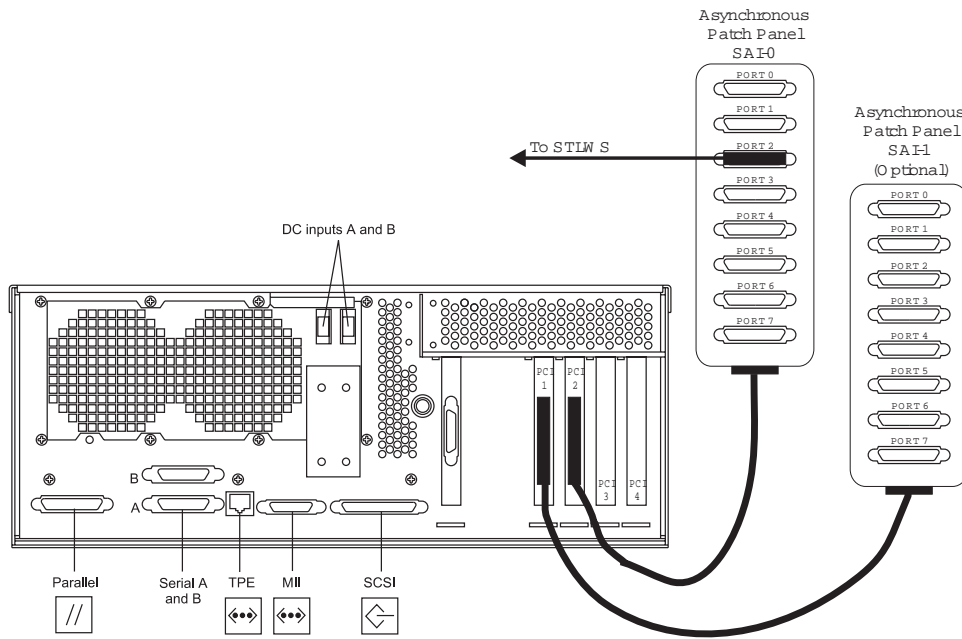

Figure 8.3-1 — STLWS Installation (Netra t 1120)

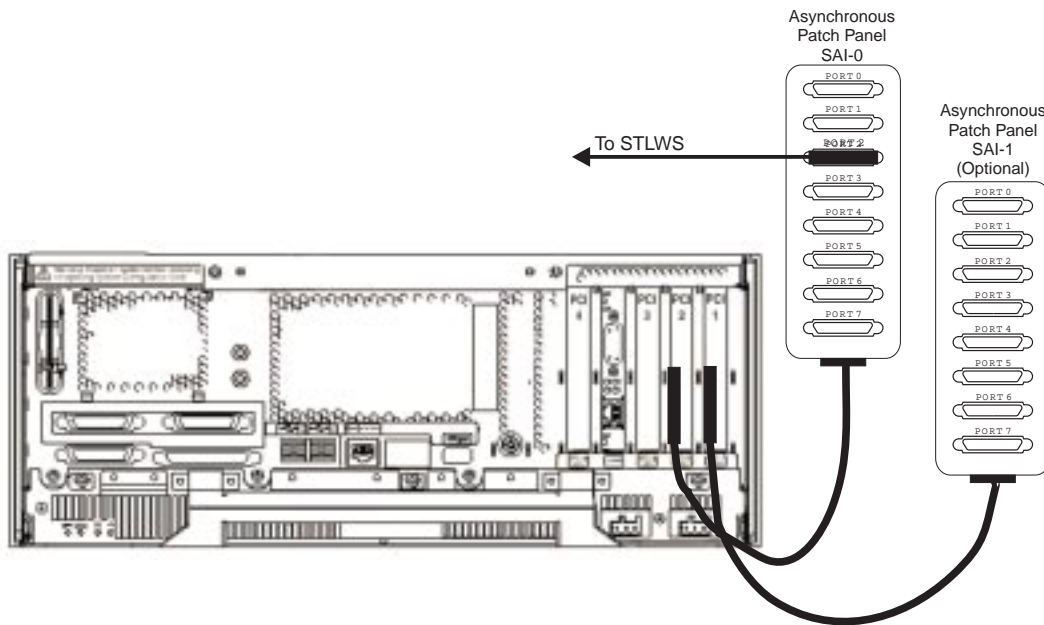

Figure 8.3-2 — STLWS Installation (Netra 20)

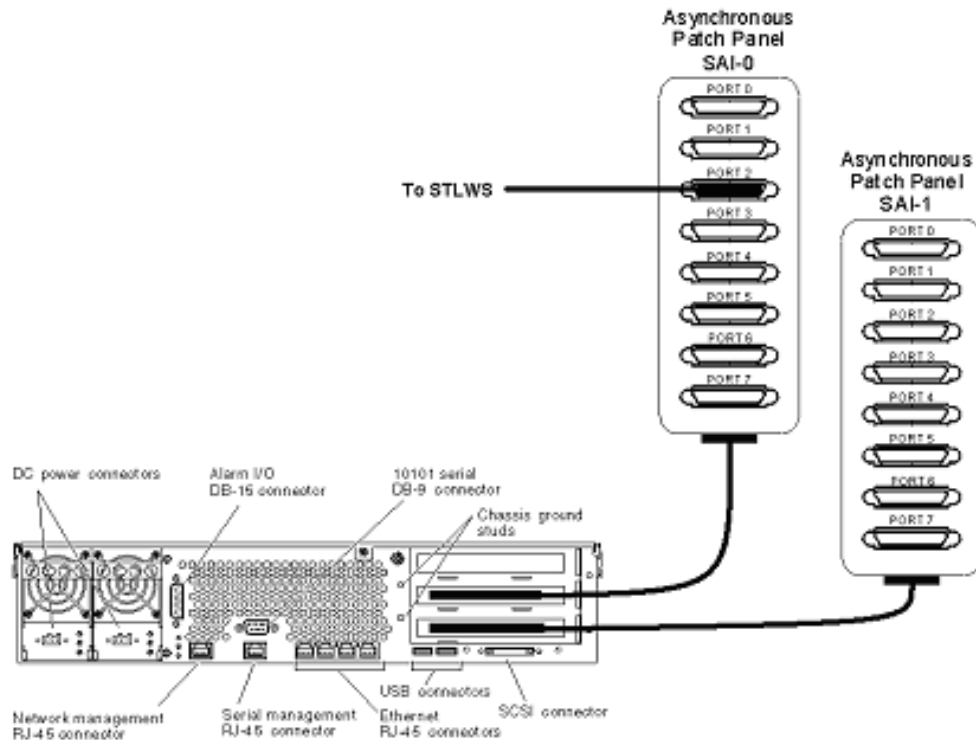

Figure 8.3-3 — STLWS Installation (Netra 240)

5. Restore TTY x to service.
 - (a) At MCC, type and enter the appropriate message:
RST:TTY=x
Where: x = appropriate TTY number.
If the Test Access Unit (TAU) is not being added to the STLWS, continue with Step 11.
 - (b) Enter CARRIAGE RETURN
Response: FORM INSERTED
 - (c) Type and enter: <
Response: Exit the ttyadd form.
 - (d) Type and enter: <
Response: Exit this recent change session.
If the TAU is not being added to the STLWS, continue with Step 11.
6. Define the STLWS trunk group.
 - (a) Select and prepare terminal for Recent Change and Verify activities.
 1. Is MCC or STLWS terminal to be used?
If MCC, proceed to substep a2.

- If STLWS, proceed to substep **a9**.
2. At MCC, ensure terminal is in command mode.
 3. Type and enter: **196**
Response: **RCV PARAMETER INFO** page displayed with cursor at PRINT OPTION.
 4. Type and enter: **y**
Response: Cursor at DETAIL OPTION
 5. Type and enter: **n**
Response: Cursor at VERBOSE OPTION
 6. Type and enter: **y**
Response: **RECENT CHANGE AND VERIFY CLASSES** menu page displayed.
 7. You have completed the Select and Prepare Terminal for the MCC, proceed to Step **b**.
 8. At the RC/V terminal, type and enter the following message:
RCV:MENU:APPRC:VERBOSE,PRINT
Response: **RECENT CHANGE AND VERIFY CLASS** menu page displayed.
- (b) Type and enter: **5.1**
Response: Enter Database Operation
I=Insert, R=Review, U=Update, D=Delete
- (c) Type and enter: **i**
Response: TRUNK GROUP page displayed. Cursor at TGN attribute.
- (d) Using the Translation Guide (TG-5) and Office Records, select and enter a TGN and the following characteristics for an STLWS trunk group:
TGN - Number from View 8.1, field 10
TRK DIR - INCOM
HUNT TYPE - NONE
TRK CLASS - ACJACK
IAPT - Y
RMK - ACJ FOR STLWS 1
INPLS - MF
Response: Enter Insert, Change, Validate, or Print
- (e) Type and enter: **i**
Response: inserting.....FORM INSERTED TRUNK GROUP page displayed.
- (f) Type and enter: **<**
Response: 5.0 TRUNKS - - TGN & MEMBER VIEWS page displayed.
7. Define the STLWS trunk group members.

- (a) Type and enter: **5**
Response: Enter Database Operation
I=Insert, R=Review, U=Update, D=Delete
 - (b) Type and enter: **i**
Response: TRUNK MEMBER page displayed. Cursor at TGN attribute.
 - (c) Using the Translation Guide (TG-5) and Office Records, enter the STLWS TGN and the following characteristics for an STLWS trunk group member.

TGN - (STLWS Trunk Group Number)
MEMB NBR - (1 to 4)
TEN - (Selected Trunk Equipment Number)
CLEI code - E54E100AXX
SUPV - EM2

Response: Enter Insert, Change, Validate, or Print:
 - (d) Type and enter: **i**
Response: inserting.....FORM INSERTED TRUNK MEMBER page displayed. Cursor at TGN attribute.
 - (e) Repeat Steps **c** and **d** for second member number.
 - (f) Type and enter: **<**
Response: 5.0 TRUNKS — TGN & MEMBER VIEWS page displayed.
 - (g) Type and enter: **q**
8. Update the STLWS trunk group.
- (a) Select and prepare terminal for Recent Change and Verify activities.
Reference: Step **6a**, substeps **1** through **9**.
 - (b) Type and enter: **5.1**
Response: Enter Database Operation
I=Insert, R=Review, U=Update, D=Delete
 - (c) Type and enter: **u**
Response: TRUNK GROUP page displayed. Cursor at TGN attribute.
 - (d) Type and enter the appropriate TGN.
Response: System completes remainder of view.
Enter Update, Change, Validate, or Print:
 - (e) Type and enter: **c**
Response: Change Field:
 - (f) Update the following characteristics for an STLWS trunk group:

TRK DIR - OUTGO
TRK CLASS - LTPDCJCK
RMK - DCJ FOR STLWS 1

Response: Enter Insert, Change, Validate, or Print:

- (g) Type and enter: **u**

Response: updating.....FORM UPDATED
TRUNK GROUP page displayed.

- (h) Type and enter: **<**

Response: 5.0 TRUNKS — TGN & MEMBER VIEWS page displayed.

9. Update the STLWS trunk group members.

- (a) Type and enter: **5**

Response: Enter Database Operation
I=Insert, R=Review, U=Update, D=Delete

- (b) Type and enter: **u**

Response: TRUNK MEMBER page displayed. Cursor at TGN attribute.

- (c) Input the appropriate TGN and MEMB NBR.

Response: System completes remainder of view.
Enter Update, Change, Validate, or Print:

- (d) Type and enter: **c**

Response: Change Field:

- (e) Using the Translation Guide TG-5 and Office Records, update the following characteristics for an STLWS trunk group member.

Response: Enter Insert, Change, Validate, or Print:

- (f) Type and enter: **u**

Response: updating.....FORM UPDATED
TRUNK MEMBER page displayed. Cursor at TGN attribute.

- (g) Repeat Steps **c** through **f** for second member number.

- (h) Type and enter: **<**

Response: 5.0 TRUNKS — TGN & MEMBER VIEWS page displayed.

- (i) Type and enter: **q**

10. Restore the AC and DC jacks.

- (a) At MCC, type and enter the following message:

RST:TRK,TKGMN=a-b,UCL:OOS,CADN;
RST:TRK,TKGMN=a-b,UCL:OOS,PPSRV;

Where: a = trunk group

b = member number.

Response: RST TRK OOS CADN COMPLETED
a b IS MAN
RST TRK OOS PPSRV COMPLETED
a b IS MAN

- (b) Repeat Step **a** for each trunk group member.

If the talk and monitor hardware is not being added to the STLWS, continue with Step 13.

11. Update the T/M number view.

- (a) Select and prepare terminal for Recent Change and Verify activities.

Reference: Step **6a**, substeps **1** through **9**.

- (b) Type and enter: **1.6**

Response: Enter Database Operation
I=Insert, R=Review, U=Update, D=Delete

- (c) Type and enter: **u**

Response: INDIVIDUAL LINE (LINE ASSIGNMENT) page displayed.
Cursor at TN attribute.

- (d) Type and enter the appropriate TN.

Response: System completes remainder of view.
Enter Update, Change, Validate, or Print:

- (e) Type and enter: **c**

Response: Change Field:

- (f) Update the following attributes.

LEN - assigned locally

LCC - must be the same as the LCC of the MCC

SUSO - Y

Response: Enter Update, Change, Validate, or Print:

- (g) Type and enter: **u**

Response: updating.....FORM UPDATED
INDIVIDUAL LINE (LINE ASSIGNMENT) page displayed.

- (h) Type and enter: **<**

Response: 1.0 LINES — TN VIEWS page displayed.

12. Update STLWS office data.

- (a) Select and prepare terminal for Recent Change and Verify activities.

Reference: Step **6a**, substeps **1** through **9**.

- (b) Type and enter: **14.3**

Response: Enter Database Operation
I=Insert, R=Review, U=Update, D=Delete

- (c) Type and enter: **u**
Response: TRUNK LINE WORK STATION page displayed. Cursor at DEVICE ID attribute.
 - (d) Type and enter the appropriate DEVICE ID.
Response: System completes remainder of view.
Enter Update, Change, Validate, or Print:
 - (e) Type and enter: **c**
Response: Change Field:
 - (f) Update this view as required.
Response: Enter Update, Change, Validate, or Print:
 - (g) Type and enter: **u**
Response: updating.....FORM UPDATED
TRUNK LINE WORK STATION page displayed.
 - (h) Type and enter: **<**
Response: 14.0 LINE & TRUNK TEST VIEWS page displayed.
13. Backup Incore ECD to disk.
- (a) At MCC, do Steps **b** through **i**.
 - (b) Type and enter: **199**
Response: RCV PARAMETER INFO page displayed with cursor at 1.
database_name
 - (c) Type and enter: **incore**
Response: 2. review only
 - (d) Type and enter: **n**
Response: 3. journaling
 - (e) Type and enter: *****
Response: UNIX RTR (ODIN) - Data Entry page displayed.
 - (f) Type and enter: **activate**
Response: activate form displayed with cursor at 1. copy_inc_to_disk:
 - (g) Type and enter: **yes**
Response: ODIN will request the action desired.
 - (h) Type and enter: **e**
Response: UNIX RTR (ODIN) - Data Entry page displayed.
 - (i) Type and enter: **<**
Response: RCV MENU RCV ECD COMPLETED
14. Backup Office Dependent Data.
- Note:** Prior to the response there will be completed responses for the switching module and the AM.

(a) At MCC, type and enter: **BKUP:ODD**

Response: BKUP ODD COMPLETED

It is recommended that primary disk be backed up and that a shelf copy of the disks be made.

15. STOP. YOU HAVE COMPLETED THIS PROCEDURE.

8.4 Perform RC/V Terminal Growth

PROCEDURE

1. Enter *UNIX*¹ RTR Recent Change and Verify.
 - (a) Is MCC or STLWS terminal to be used?
For MCC, proceed to Step **b**.
For STLWS proceed to Step **i**.
 - (b) At MCC, ensure terminal is in command mode.
 - (c) At MCC, do Steps **d** through **h**.
 - (d) Type and enter: **199**
Response: RCV PARAMETER INFO page displayed with cursor at 1.
database_name
 - (e) Type and enter: **incore**
Response: 2. review only
 - (f) Type and enter: **n**
Response: 3. journaling
 - (g) Type and enter: *****
Response: RCV INITIALIZATION IN PROGRESS message displayed.
UNIX RTR RCV (ODIN) - Data Entry page displayed.
 - (h) You have completed Enter *UNIX* RTR Recent Change and Verify, proceed to Step **2**.
 - (i) At STLWS terminal, type and enter: **RCV:MENU:DATA,RCVECD**
Response: RCV ECD PARAMETER INFO page displayed with cursor at 1.
database_name
 - (j) Type and enter: **incore**
Response: 2. review only
 - (k) Type and enter: **n**
Response: 3. journaling
 - (l) Type and enter: *****
Response: RCV INITIALIZATION IN PROGRESS message displayed.
UNIX RTR RCV (ODIN) - Data Entry page displayed. Cursor
at Enter Form Name:
2. Enter high-level forms.
 - (a) Type and enter: **toggle**
Response: Will take you to the high-level forms.
3. Insert TTY data.

1. Registered trademark in the United States and other countries, licensed exclusively through X/Open Company, Limited.

Note: An ! may be entered any time prompted to abort the form and return to the state when the form was started.

- (a) Type and enter: **ttyadd**

Response: ttyadd form displayed. Cursor at 1.tty_name:

Note: An ! may be entered any time prompted to abort the form and return to the state when the form was started.

- (b) Type and enter the following data:

1. tty_name^a: enter TTY terminal name (TTY18, TTY19, or TTY21)
2. baud_rate: enter (as specified or CARRIAGE RETURN)
3. login_term: enter (as specified or CARRIAGE RETURN)
4. auth_chk: enter (as specified or CARRIAGE RETURN)
5. term_type: enter (as specified or CARRIAGE RETURN)
6. line_mode: enter (as specified or CARRIAGE RETURN)
7. port: enter 2 or 3 for TTYC port (see Table 8.3-1 and 8.3-2)
8. ttyc_number: enter TTYC number base on SAI port (see Table 8.3-1 and 8.3-2)
9. plu_unit_name: enter CARRIAGE RETURN
10. plu_unit_number: enter CARRIAGE RETURN

Note(s):

- a. tty_name must be entered in all capital letters.

- (c) Type and enter: **i**

Note: When growing a TTY terminal a defensive check failure message REPT CONFIG FAULT Assert = 412 may be received. This failure message may be ignored.

4. Install the RC/V terminal to the SAI port corresponding to the TTYC port and TTYC number chosen in Table 8.3-1 and 8.3-2 (see Figure 8.4-1 , 8.4-2 and 8.4-3).

- (a) Enter CARRIAGE RETURN

2. Trademark of Sun Microsystems, Inc.

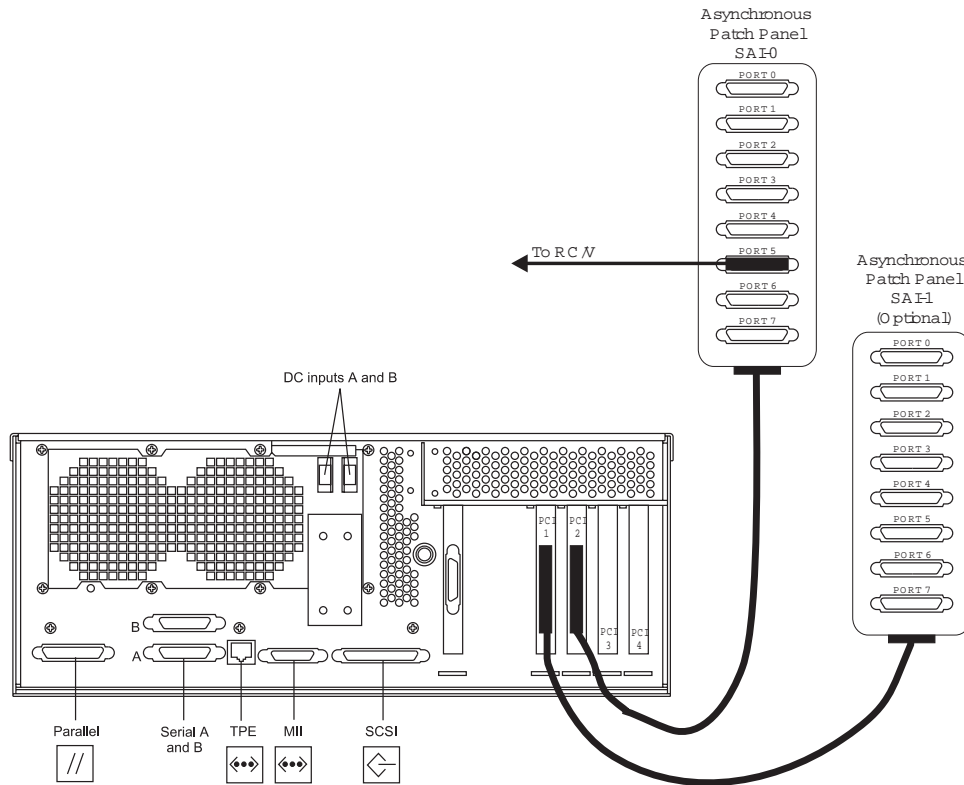

Figure 8.4-1 — Recent Change Terminal Installation (*Netra*² t 1120)

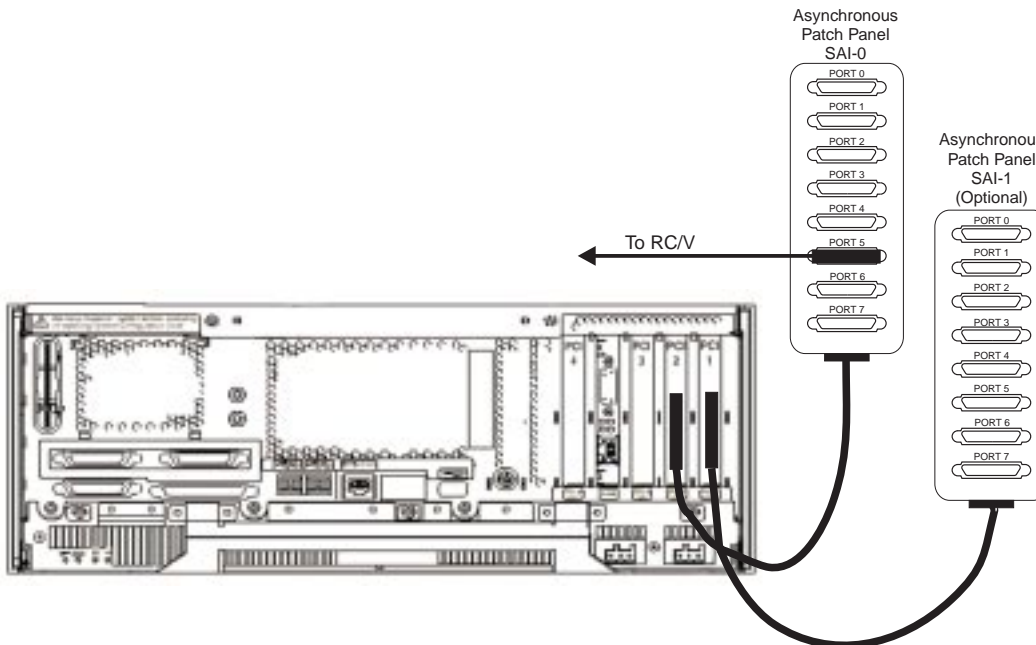

Figure 8.4-2 — Recent Change Terminal Installation (*Netra* 20)

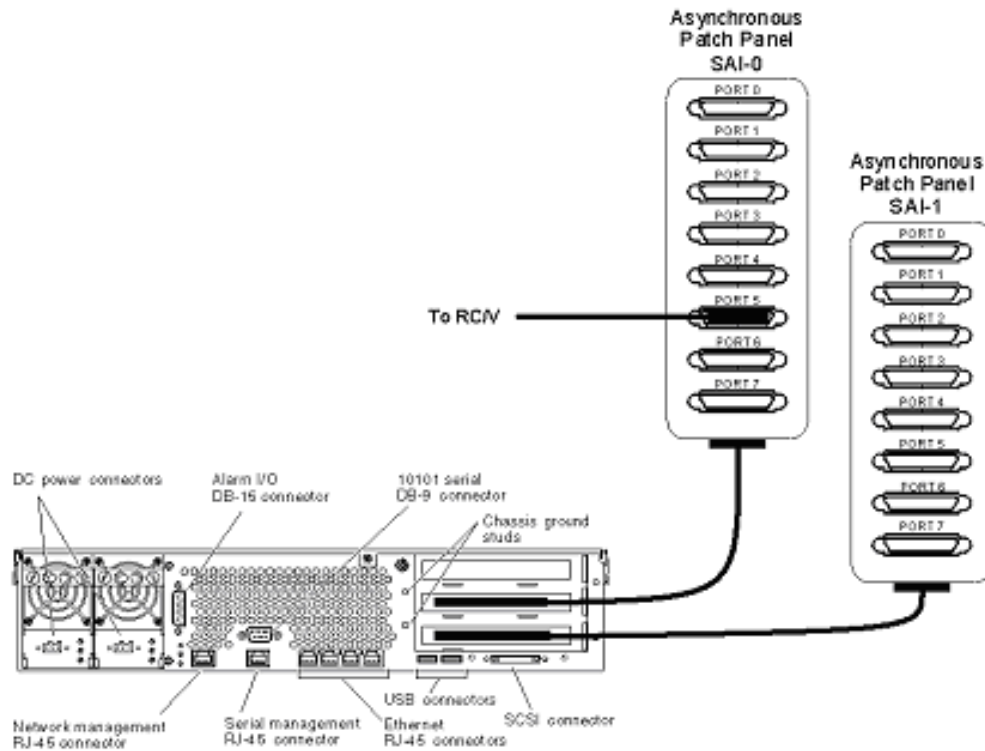

Figure 8.4-3 — Recent Change Terminal Installation (Netra 240)

5. Restore TTY x to service.
 - (a) At MCC, type and enter the appropriate message:
RST:TTY=x
Where: x = appropriate TTY number.
Response: RST TTY x COMPLETED
 - (b) Enter CARRIAGE RETURN
Response: FORM INSERTED
 - (c) Type and enter: <
Response: Exit the ttyadd form.
 - (d) Type and enter: <
Response: Exit this recent change session.
6. Backup Incore ECD to disk.
 - (a) At MCC, do Steps **b** through **i**.
 - (b) Type and enter: **199**
Response: RCV PARAMETER INFO page displayed with cursor at 1.
database_name
 - (c) Type and enter: **incore**
Response: 2. review only

- (d) Type and enter: **n**
Response: 3. journaling
 - (e) Type and enter: *****
Response: UNIX RTR (ODIN) - Data Entry page displayed.
 - (f) Type and enter: **activate**
Response: activate form displayed with cursor at 1. copy_inc_to_disk:
 - (g) Type and enter: **yes**
Response: ODIN will request the action desired.
 - (h) Type and enter: **e**
Response: ODIN returns to the UNIX RTR (ODIN) - Data Entry page.
 - (i) Type and enter: **<**
Response: RCV MENU RCV ECD COMPLETED
7. Change Security
- (a) At MCC, type and enter message:
SET:RCACCESS,TTY=a,ACCESS=b
Where: a = ttys, ttyt, or ttyv
Where: ttys = TTY18
ttyt = TTY19
ttyv = TTY21
Where b is obtained from INPUT/OUTPUT Manual.
 - (b) To check on the access code, type and enter message:
OP:RCACCESS,TTY=a
Where: a = ttys, ttyt, or ttyv
Where: ttys = TTY18
ttyt = TTY19
ttyv = TTY21
Response: Access code returned in hexadecimal
8. Backup Office Dependent Data.
- Note:** Prior to the response there will be completed responses for the switching module and the AM.
- (a) At MCC, type and enter: **BKUP:ODD**
Response: BKUP ODD COMPLETED
It is recommended that primary disk be backed up and that a shelf copy of the disks be made.
9. **STOP. YOU HAVE COMPLETED THIS PROCEDURE.**

8.5 Grow MCC Dial-Up Modem Access

OVERVIEW

Through the use of commercially/Lucent available hardware, another option for accessing the DRM's MCC is over a dial-up modem connection.

Note: Transmitted and received data will be echoed on both the local (if equipped) and dial-up MCC (this configuration does not provide two separate independent MCC interfaces to the DRM). As a result, care must be taken to ensure that two operators do not try accessing the MCC at the same time.

Table 8.5-1 lists the required hardware for the dial-up MCC.

Table 8.5-1 — Dial-Up MCC Hardware Requirements

Item	Lucent Comcode	3rd Party Source
Serial Splitter	407947290	Black Box Corp TL073A-R2
Modem A ^a (local modem)	106597768	Paradyne Corp Model 3810
Modem B (remote modem)	106597768	Paradyne Corp Model 3810 or Any 9600 baud compatible modem
Cable 1	407645092 (10ft) or 407645118 (50ft)	Black Box Corp EYN251-0010-MM (10ft) or EYN251-0050-MM (50ft)
Cable 2	407645092 (10ft) or 407645118 (50ft)	Black Box Corp EYN251-0010-MM (10ft) or EYN251-0050-MM (50ft)
Cable 3 ^b	407667351 (25ft) or 407667369 (50ft) or 407667377 (100ft)	Black Box Corp EDN16C-0025-MM (25ft) or EDN16C-0050-MM (50ft) or EDN16C-0100-MM (100ft)
Dial-Up MCC Terminal	407552488 (KS23996 MCC), 408800027 (KS24697L1 MCC), or PC running Lucent's AIMS MCC terminal emulator software	Any vt100 compatible terminal or PC running a vt100 terminal emulator
<p>Note(s):</p> <p>a. A generic 9600 baud modem is not recommended for the local modem.</p> <p>b. If Cable 3 is being connected to a PC running the Lucent AIMS MCC terminal emulator software, a DB25 to DB9 connector adapter may also be required depending on the type of serial port equipped on the PC running the AIMS software.</p>		

PROCEDURE

Warning: *This growth procedure requires the workstation to be halted and powered down. This procedure should be scheduled to ensure that it does not interfere with any other planned maintenance activity.*

1. Ensure that there is no Recent Change/Verify (RC/V) activity in progress.
2. Ensure that there is no SCANS session in progress.
3. Ensure that there is no AMA teleprocessing or tape writing sessions in progress.
4. Verify that all database updates have been written to disk.
 - (a) Enter the following input command on the MCC or a STLWS: **BKUP:ODD**;
Response: BKUP ODD COMPLETED
5. Write all AMA billing records from memory to disk.
 - (a) Type and enter command: **WRT:AMADATA**
Response: AMA DATA HAS BEEN WRITTEN TO DISK
READY TO TRANSFER DATA FROM DISK TO
OUTPUT MEDIUM
6. Isolate the switching module from the AW.
 - (a) Go to the Switching Module Inhibit and Recovery Control Page. Type and enter command: **1800**
 - (b) Manually isolate the switching module. Type and enter: **403**
Response: ISOLATE (Y/N)
 - (c) Type and enter: **y**
Response: SET ISOL SM=1 COMPLETED
7. Enter poke **59** on the MCC EAI page to halt the AM emulator.
Response: Terminate Emulator (Y/N)?
8. Type and enter: **y**
9. Switch to the *Sun¹ UNIX²* Console of the AW by holding down the **Ctrl** key and pressing the **Enter** key on the MCC's numeric keypad.
10. If a login prompt does not appear, press **Return** repeatedly until one appears.
11. At the login prompt, type and enter: **awadmin**
12. From the Administrative Workstation Main Menu, select the "Halt the Workstation" option. Answer **yes** to the confirmation. If you select a task by mistake, answer **no** to the confirmation and the main menu will appear.
Response:
You have chosen to halt the workstation. If the emulator is running, it must be halted before continuing. Refer to the main menu item of Halt the Emulator.

1. Registered trademark of Sun Microsystems, Inc.
2. Registered trademark in the United States and other countries, licensed exclusively through X/Open Company, Limited.

- Do you want to continue (yes/no): **yes**
13. Wait for the **ok** prompt to appear.
 14. Power down the AW units and MCC terminal in the following order:
For a *Netra*³ t 1120 or *Netra* 20 workstation:
 1. *Netra* t 1120 and *Netra* 20 workstation. See "Remove Power to Administrative Workstation (*Netra* t 1120 and *Netra* 20)", Procedure 4.7.
 2. MCC terminalFor a *Netra* 240 workstation:
 1. *Netra* 240 workstation and external tape device. See "Remove Power to Administrative Workstation Units (*Netra* 240)", Procedure 4.9.
 2. MCC terminal
 15. Connect the dial-up MCC hardware as shown in Figure 8.5-1. Refer to Table 8.5-1 for cable designations.

3. Trademark of Sun Microsystems, Inc.

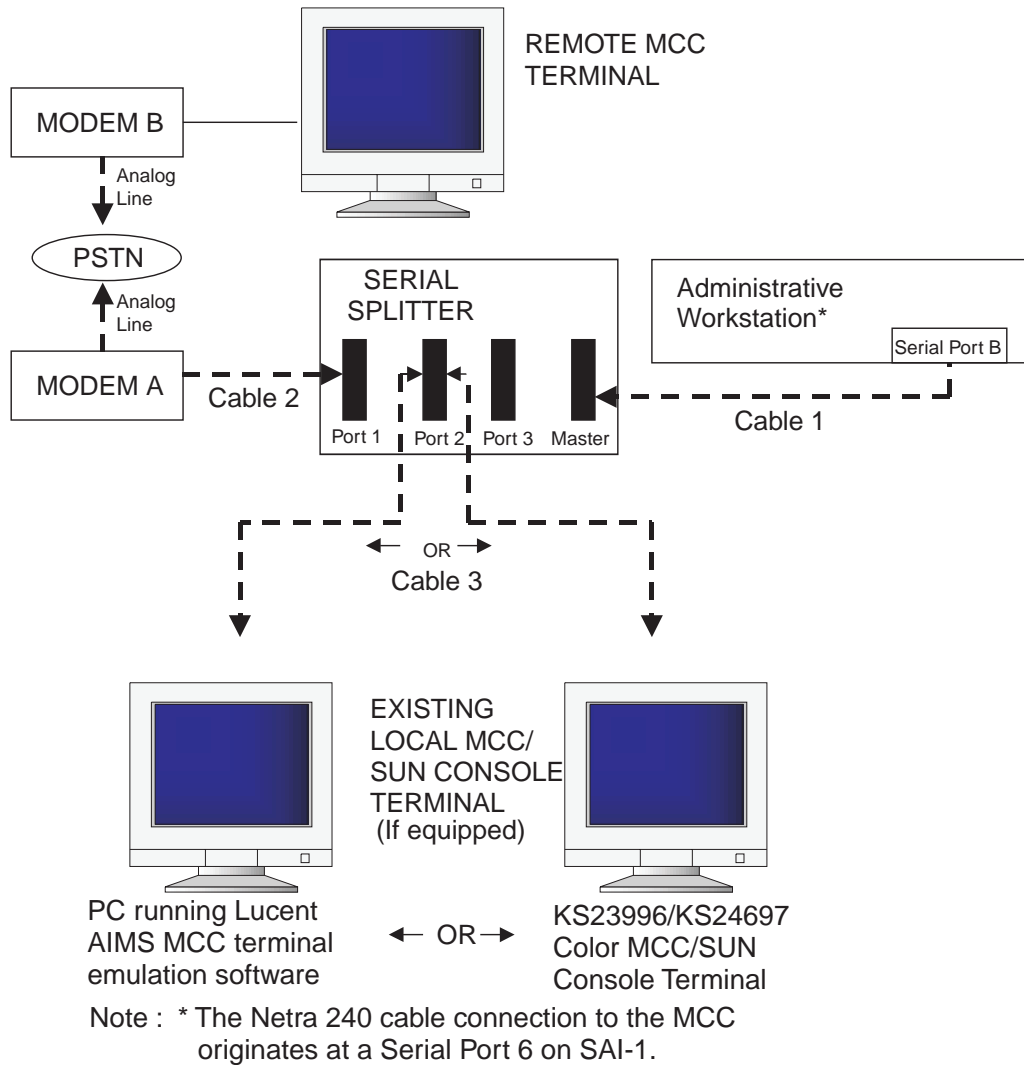

Figure 8.5-1 — Dial-Up MCC Hardware Connections

- Follow the Paradyne 3810 user manual to set Modem A to the factory async default settings with the following exceptions:

DTE_Interface:

DTE Rate = 9600
 Data Bits = 7
 Parity = Even
 DTR Action = Ignore
 DSR Control = Standard RS232
 RTS Action = Standard RS232

DTE_Dialer:

DTE Dialer Type = Disable

Dial_Line:

Dial Line Rate = 9600

V42/MNP/Buffer:

V42bic Compress = Disable
MNP5 Compress = Disable
Flw Cntl of DTE = XON/XOFF
Flw Cntl Of Modem
= XON/XOFF

Security:

IMPORTANT: To prevent unauthorized access to the DRM's MCC, set per local guidelines.

17. If Modem B is a Paradyne 3810 modem, set the modem options on Modem B to the same values as Modem A with the exception of the "DTE Dialer Type" field in the "DTE_Dialer" submenu. For Modem B, "DTE Dialer Type" should be set to Enable. If Modem B is not a Paradyne 3810 modem, follow the user manual provided with the modem to provision it so that its communication parameters (primarily the baud rate, parity, stop bits, and data bits) match that of Modem A.
18. Follow the user manual provided with the dial-up MCC terminal or terminal emulator software package to set the communication parameters on the dial-up MCC terminal to match those of the modems (for example, 9600 baud, 7 data bits, 1 stop bit, Even parity).
19. Power up the AW units and dial-up MCC hardware in the following order:
For a *Netra t 1120* or *Netra 20* workstation:
 1. MCC terminal
 2. Modem A (Paradyne 3810)
 3. *Netra t 1120* and *Netra 20* workstation. See "Restore Power to Administrative Workstation (*Netra t 1120* and *Netra 20*)", Procedure 4.8.For a *Netra 240* workstation:
 1. MCC terminal
 2. Modem A (Paradyne 3810)
 3. *Netra 240* workstation and external tape device. See "Restore Power to Administrative Workstation Units (*Netra 240*)", Procedure 4.10.
20. Verify that the local MCC terminal is functional.
21. Verify that the dial-up MCC can be accessed.
 - a. Power up the dial-up MCC terminal and Modem B.
 - b. If the security options have not been set up on Modem A, type and enter: **ATDTxxxxyyy** at the dial-up MCC terminal.
where xxxxyyy = the phone number of the analog line connected to Modem A.

If the security options are set up on Modem A to require a password for connection, type and enter: **ATDTxxxxyyyWaaaaaaaa#**
where: xxxxyyy = the phone number of the analog line to Modem A, and
aaaaaaaa = the 8 digit numeric password.

- c. Wait for Modem A to be dialed and then verify that the MCC pages can be accessed once the modem connection is established.
 - d. Drop the dial-up MCC connection. Type and enter: **+++** at the dial-up MCC terminal to enter the modem's online command mode. Then, type and enter: **ATH0** to drop the connection.
22. **STOP. YOU HAVE COMPLETED THIS PROCEDURE.**

8.6 Grow Remote Sun¹ Console Dial-Up Modem Access

OVERVIEW

Through the use of commercially/Lucent available hardware, another option for accessing the DRM's *Sun* console is over a dial-up modem connection.

Note: Transmitted and received data will be echoed on both the local (if equipped) and dial-up *Sun* console (this configuration does not provide two separate independent *Sun* console interfaces to the DRM). As a result, care must be taken to ensure that two operators do not try accessing the *Sun* console at the same time.

Table 8.6-1 lists the required hardware for the dial-up *Sun* console.

Table 8.6-1 — Dial-Up Sun Console Hardware Requirements

Item	Lucent Comcode	3rd Party Source
Serial Splitter	407947290	Black Box Corp TL073A-R2
Modem A ^a (local modem)	106597768	Paradyne Corp Model 3810
Modem B (remote modem)	106597768	Paradyne Corp Model 3810 or Any 9600 baud compatible modem
Cable 1	407645092 (10ft) or 407645118 (50ft)	Black Box Corp EYN251-0010-MM (10ft) or EYN251-0050-MM (50ft)
Cable 2	407645092 (10ft) or 407645118 (50ft)	Black Box Corp EYN251-0010-MM (10ft) or EYN251-0050-MM (50ft)
Cable 3 ^b	407667351 (25ft) or 407667369 (50ft) or 407667377 (100ft)	Black Box Corp EDN16C-0025-MM (25ft) or EDN16C-0050-MM (50ft) or EDN16C-0100-MM (100ft)
Cable 4	407947340 (50ft)	Black Box Corp EVNLS03-0050 (50ft) or Standard CAT5 RJ45 cable
Cable Adapter (RJ45 female to DB25 male straight-through connector)	403602717	Northern Technologies FM-010

1. Registered trademark of Sun Microsystems, Inc.
See note(s) at end of table.

Table 8.6-1 — Dial-Up *Sun* Console Hardware Requirements (Contd)

Item	Lucent Comcode	3rd Party Source
Dial-Up <i>Sun</i> Console Terminal	407552488 (KS23996 MCC), 408800027 (KS24697L1 MCC) or PC running Lucent's AIMS terminal emulator software	Any vt100 compatible terminal ^c or PC running a vt100 terminal emulator
Note(s): a. A generic 9600 baud modem is not recommended for the local modem. b. If a PC running the Lucent AIMS terminal emulator software is being used as the local <i>Sun</i> console terminal, a DB25 to DB9 connector adapter may also be required depending on the type of serial port equipped on the PC running the AIMS software. Cable 4 and the cable adapter are not needed when connecting to a local PC running AIMS. Refer to Figure 8.6-1 for more information. c. Not supported by Lucent Technologies		

PROCEDURE

Warning: *This growth procedure requires the workstation to be halted and powered down. This procedure should be scheduled to ensure that it does not interfere with any other planned maintenance activity.*

1. Ensure that there is no Recent Change/Verify (RC/V) activity in progress.
2. Ensure that there is no SCANS session in progress.
3. Ensure that there is no AMA teleprocessing or tape writing sessions in progress.
4. Verify that all database updates have been written to disk.
 - (a) Enter the following input command on the MCC or a STLWS: **BKUP:ODD;**
 Response: BKUP ODD COMPLETED
5. Write all AMA billing records from memory to disk.
 - (a) Type and enter command: **WRT:AMADATA**
 Response: AMA DATA HAS BEEN WRITTEN TO DISK
 READY TO TRANSFER DATA FROM DISK TO
 OUTPUT MEDIUM
6. Isolate the switching module from the AW.
 - (a) Go to the Switching Module Inhibit and Recovery Control Page. Type and enter command: **1800**
 - (b) Manually isolate the switching module. Type and enter: **403**
 Response: ISOLATE (Y/N)
 - (c) Type and enter: **Y**
 Response: SET ISOL SM=1 COMPLETED

7. Enter poke **59** on the MCC EAI page to halt the AM emulator.
Response: Terminate Emulator (Y/N)?
8. Type and enter: **y**
9. Switch to the *Sun UNIX*² Console of the AW by holding down the **Ctrl** key and pressing the **Enter** key on the MCC's numeric keypad.
10. If a login prompt does not appear, press **Return** repeatedly until one appears.
11. At the login prompt, type and enter: **awadmin**
12. From the Administrative Workstation Main Menu, select the "Halt the Workstation" option. Answer **yes** to the confirmation. If you select a task by mistake, answer **no** to the confirmation and the main menu will appear.
Response:
You have chosen to halt the workstation. If the emulator is running, it must be halted before continuing. Refer to the main menu item of Halt the Emulator.
Do you want to continue (yes/no): **yes**
13. Wait for the **ok** prompt to appear.
14. Power down the AW units and *Sun* console terminal in the following order:
For a *Netra*³ t 1120 or *Netra* 20 workstation:
 1. *Netra* t 1120 and *Netra* 20 workstation. See "Remove Power to Administrative Workstation (*Netra* t 1120 and *Netra* 20)", Procedure 4.7.
 2. *Sun* console terminalFor a *Netra* 240 workstation:
 1. *Netra* 240 workstation and external tape device. See "Remove Power to Administrative Workstation Units (*Netra* 240)", Procedure 4.9.
 2. *Sun* console terminal
15. Connect the dial-up *Sun* console hardware as shown in Figure 8.6-1. Refer to Table 8.6-1 for cable designations.

2. Registered trademark in the United States and other countries, licensed exclusively through X/Open Company, Limited.
3. Trademark of Sun Microsystems, Inc.

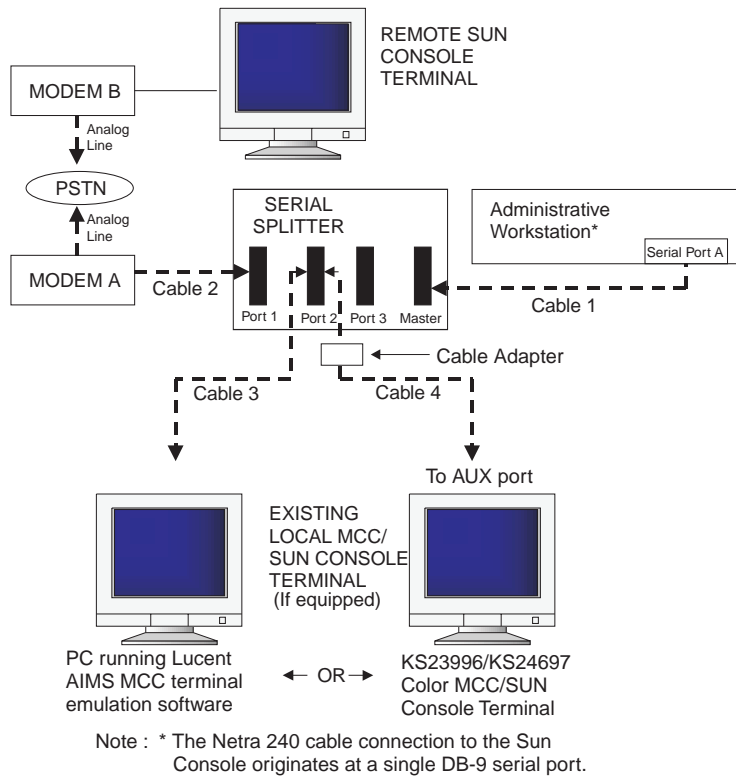

Figure 8.6-1 — Dial-Up Sun Console Hardware Connections

- Follow the Paradyne 3810 user manual and set the modem options on Modem A to the factory async default settings with the following exceptions:

DTE_Interface:

DTE Rate = 9600
 Data Bits = 8
 Parity = None
 DTR Action = Ignore
 DSR Control = Standard RS232
 RTS Action = Standard RS232

DTE_Dialer:

DTE Dialer Type = Disable

Dial_Line:

Dial Line Rate = 9600

V42/MNP/Buffer:

V42bic Compress = Disable
 MNP5 Compress = Disable
 Flw Cntl of DTE = XON/XOFF
 Flw Cntl Of Modem = XON/XOFF

Security:

IMPORTANT: To prevent unauthorized access to the DRM's *Sun* console, set per local guidelines.

17. If Modem B is a Paradyne 3810 modem, set the modem options on Modem B to the same values as Modem A with the exception of the "DTE Dialer Type" field in the "DTE_Dialer" submenu. For Modem B, "DTE Dialer Type" should be set to Enable. If Modem B is not a Paradyne 3810 modem, follow the user manual provided with the modem to provision it so that its communication parameters (primarily the baud rate, parity, stop bits, and data bits) match that of Modem A.
18. Follow the user manual provided with the dial-up *Sun* console terminal or terminal emulator software package to set the communication parameters on the dial-up *Sun* console terminal to match those of the modems (for example, 9600 baud, 8 data bits, 1 stop bit, No parity).
19. Power up the AW units and dial-up *Sun* console hardware in the following order:
For a *Netra* t 1120 or *Netra* 20 workstation:
 1. Local MCC/*Sun* console terminal
 2. Modem A (Paradyne 3810)
 3. *Netra* t 1120 and *Netra* 20 workstation. See "Restore Power to Administrative Workstation (*Netra* t 1120 and *Netra* 20)", Procedure 4.8.For a *Netra* 240 workstation:
 1. Local MCC/*Sun* console terminal
 2. Modem A (Paradyne 3810)
 3. *Netra* 240 workstation and external tape device. See "Restore Power to Administrative Workstation Units (*Netra* 240)", Procedure 4.10.
20. Verify that the local *Sun* console terminal is functional.
21. Verify that the *Sun* console can be accessed via the modem.
 - a. Power up the dial-up *Sun* console terminal and Modem B.
 - b. If the security options have not been set up on Modem A, type and enter: **ATDTxxxxyyy** at the dial-up *Sun* console terminal.
where xxxxyyy = the phone number of the analog line connected to Modem A.

If the security options are set up on Modem A to require a password for connection, type and enter: **ATDTxxxxyyyWaaaaaaa#**
where: xxxxyyy = the phone number of the analog line to Modem A, and
aaaaaaa = the 8 digit numeric password.
 - c. Wait for Modem A to be dialed and then verify that the *Sun* console pages can be accessed once the modem connection is established.

Warning: Do not hit the break key on the dial-up Sun console terminal. Sending a break on the DRM's Sun console port will cause the Sun workstation to halt. If a break is inadvertently sent, an ok prompt will be displayed on the Sun console. Simply type and enter go at the ok prompt to allow the administrative workstation to resume operation.

- d. Drop the dial-up *Sun* console connection. Type and enter: **+++** at the dial-up *Sun* console terminal to enter the modem's online command mode. Then, type and enter: **ATH0** to drop the connection.
22. **STOP. YOU HAVE COMPLETED THIS PROCEDURE.**

8.7 Perform SCANS Data Link Growth

PROCEDURE

1. Enter *UNIX*¹ RTR Recent Change and Verify.
 - (a) Is MCC or STLWS terminal to be used?
For MCC, proceed to Step **b**.
For STLWS proceed to Step **i**.
 - (b) At MCC, ensure terminal is in command mode.
 - (c) At MCC, do Steps **d** through **h**.
 - (d) Type and enter: **199**
Response: RCV PARAMETER INFO page displayed with cursor at 1.
database_name
 - (e) Type and enter: **incore**
Response: 2. review only
 - (f) Type and enter: **n**
Response: 3. journaling
 - (g) Type and enter: *****
Response: RCV INITIALIZATION IN PROGRESS message displayed.
UNIX RTR RCV (ODIN) - Data Entry page displayed.
 - (h) You have completed Enter *UNIX* RTR Recent Change and Verify, proceed to Step **2**.
 - (i) At STLWS terminal, type and enter: **RCV:MENU:DATA,RCVECD**
Response: RCV ECD PARAMETER INFO page displayed with cursor at 1.
database_name
 - (j) Type and enter: **incore**
Response: 2. review only
 - (k) Type and enter: **n**
Response: 3. journaling
 - (l) Type and enter: *****
Response: RCV INITIALIZATION IN PROGRESS message displayed.
UNIX RTR RCV (ODIN) - Data Entry page displayed.
2. Enter high-level forms.
 - (a) Type and enter: **toggle**
Response: Will take you to the high-level forms.
3. Insert SDL data.

1. Registered trademark in the United States and other countries, licensed exclusively through X/Open Company, Limited.

Note: An ! may be entered any time prompted to abort the form and return to the state when the form was started.

Note: Fields not specified receive the default value by entering CARRIAGE RETURN.

- (a) Type and enter: **sdladd**
Response: ttyadd form displayed. Cursor at 1. sdl_name:
 - (b) Type and enter the following data:
 - 1. sdl_name: enter **SDL0**
 - 2. port: enter **0**
 - 3. SCANS_baud_rate: enter **CARRIAGE RETURN**
 - (c) **Type and enter: i**
 - (d) The low-level forms will now be added automatically.
4. Install the SCANS data link. (See Figures 8.7-1 , 8.7-2 and 8.7-3 for hardware connection information.)
- (a) Enter CARRIAGE RETURN

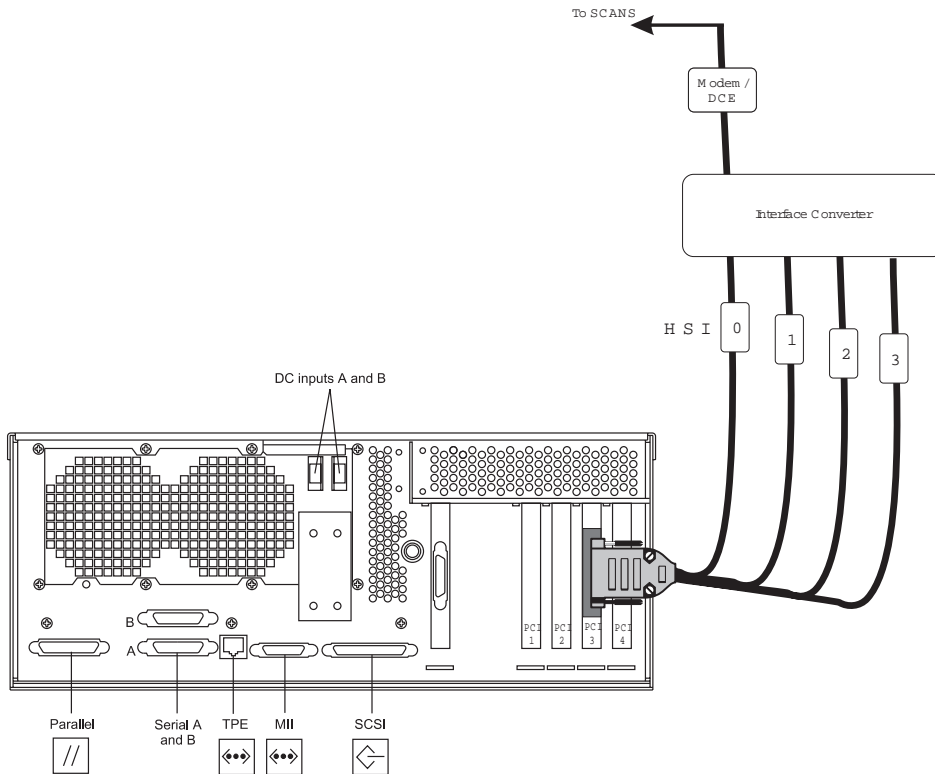

Figure 8.7-1 — SCANS Data Link Hardware Installation (Netra² t 1120)

2. Trademark of Sun Microsystems, Inc.

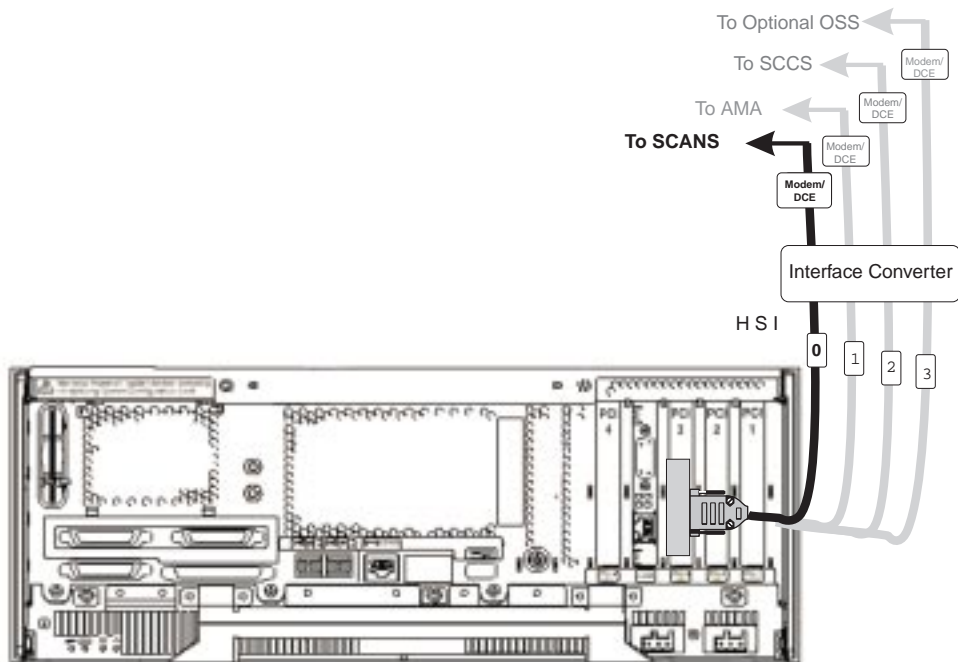

Figure 8.7-2 — SCANS Data Link Hardware Installation (Netra 20)

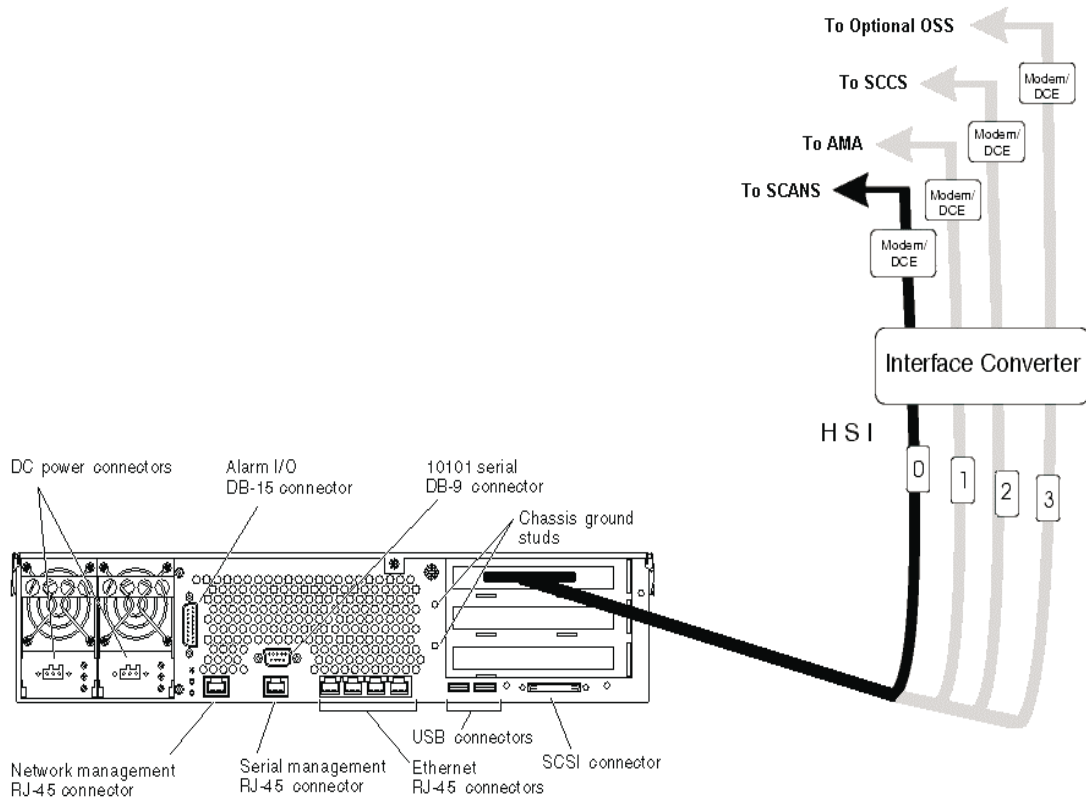

Figure 8.7-3 — SCANS Data Link Hardware Installation (Netra 240)

5. Restore SDL0 to service.
 - (a) At MCC, type and enter the appropriate message:
RST:SDL=0
Response: RST SDL0 COMPLETED
 - (b) Enter CARRIAGE RETURN
Response: FORM INSERTED
 - (c) Type and enter: <
Response: Exit the sdladd form.
 - (d) Type and enter: <
Response: Exit this recent change session.
6. Backup Incore ECD to disk.
 - (a) At MCC, do Steps **b** through **i**.

- (b) Type and enter: **199**
Response: RCV PARAMETER INFO page displayed with cursor at 1.
database_name
 - (c) Type and enter: **incore**
Response: 2. review only
 - (d) Type and enter: **n**
Response: 3. journaling
 - (e) Type and enter: *****
Response: UNIX RTR (ODIN) - Data Entry page displayed.
 - (f) Type and enter: **activate**
Response: activate form displayed with cursor at 1. copy_inc_to_disk:
 - (g) Type and enter: **y**
Response: ODIN will request the action desired.
 - (h) Type and enter: **e**
Response: ODIN will return to the UNIX RTR (ODIN) - Data Entry page.
 - (i) Type and enter: **<**
Response: RCV MENU RCV ECD COMPLETED
7. Backup Office Dependent Data.
- Note:** Prior to the response there will be completed responses for the switching module and the AM.
- (a) At MCC, type and enter: **BKUP:ODD**
Response: BKUP ODD COMPLETED
It is recommended that primary disk be backed up and that a shelf copy of the disks be made.
8. Go to MCC display page **113** and verify that the data link shows up there.
9. **STOP. YOU HAVE COMPLETED THIS PROCEDURE.**

8.8 Perform AMA Data Link Growth

OVERVIEW

The AMA data link provides the hardware interface for the *BILLDATS*¹ software used to transmit AMA data to a host collector.

PROCEDURE

1. Enter *UNIX*² RTR Recent Change and Verify.
 - (a) Is MCC or STLWS terminal to be used?
For MCC, proceed to Step **b**.
For STLWS proceed to Step **i**.
 - (b) At MCC, ensure terminal is in command mode.
 - (c) At MCC, do Steps **d** through **h**.
 - (d) Type and enter: **199**
Response: RCV PARAMETER INFO page displayed with cursor at 1.
database_name
 - (e) Type and enter: **incore**
Response: 2. review only
 - (f) Type and enter: **n**
Response: 3. journaling
 - (g) Type and enter: *****
Response: RCV INITIALIZATION IN PROGRESS message displayed.
UNIX RTR RCV (ODIN) - Data Entry page displayed.
 - (h) You have completed Enter *UNIX* RTR Recent Change and Verify, proceed to Step **2**.
 - (i) At STLWS terminal, type and enter: **RCV:MENU:DATA,RCVECD**
Response: RCV ECD PARAMETER INFO page displayed with cursor at 1.
database_name
 - (j) Type and enter: **incore**
Response: 2. review only
 - (k) Type and enter: **n**
Response: 3. journaling
 - (l) Type and enter: *****
Response: RCV INITIALIZATION IN PROGRESS message displayed.
UNIX RTR RCV (ODIN) - Data Entry page displayed.
2. Enter high-level forms.

1. Registered trademark of AT&T Corp.

2. Registered trademark in the United States and other countries, licensed exclusively through X/Open Company, Limited.

- (a) Type and enter: **toggle**
Response: Will take you to the high-level forms.
- 3. Insert SDL data.
 - (a) Type and enter: **sdladd**
Response: ttyadd form displayed. Cursor at 1. sdl_name:
Note: An ! may be entered any time prompted to abort the form and return to the state when the form was started.
 - (b) Type and enter the following data:
 - 1. sdl_name: enter **SDL13.**
 - 2. port: enter **1**
 - 3. AMA_baud_rate: enter one of the following:
 - 4800DIAL**
 - 9600DIAL**
 - 9600PRI**
 - 56000PRI**
 - 56000SW**
 - Note:** Fields not specified receive the default value by entering CARRIAGE RETURN.
 - (c) Type and enter: **i**
 - (d) The low-level forms will now be added automatically.
- 4. Install the AMA data link. The AMA data link consists of a modem and modem cable connected to the High Speed Bus controller interface. (Figures 8.8-1, 8.8-2 and 8.8-3 provide an illustration of the hardware connections for the AMA data link.)
 - (a) Enter CARRIAGE RETURN

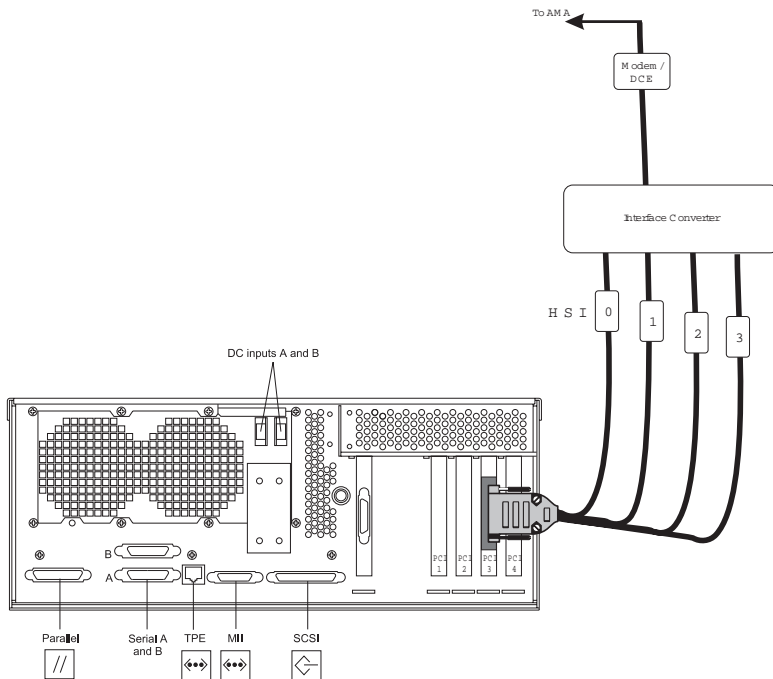

Figure 8.8-1 — AMA Data Link Hardware Connection (*Netra³ t 1120*)

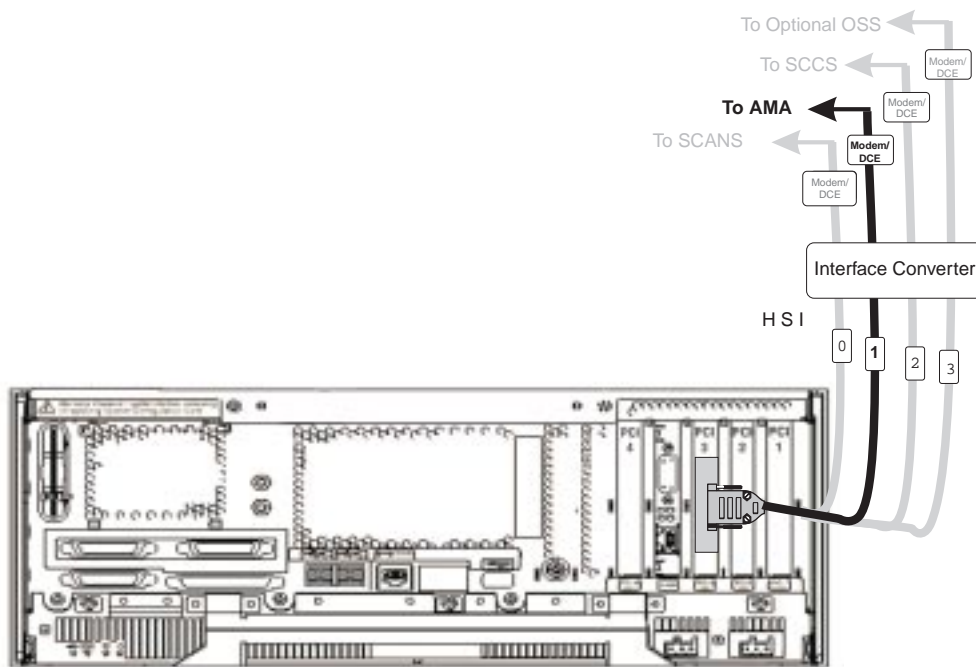

Figure 8.8-2 — AMA Data Link Hardware Installation (*Netra 20*)

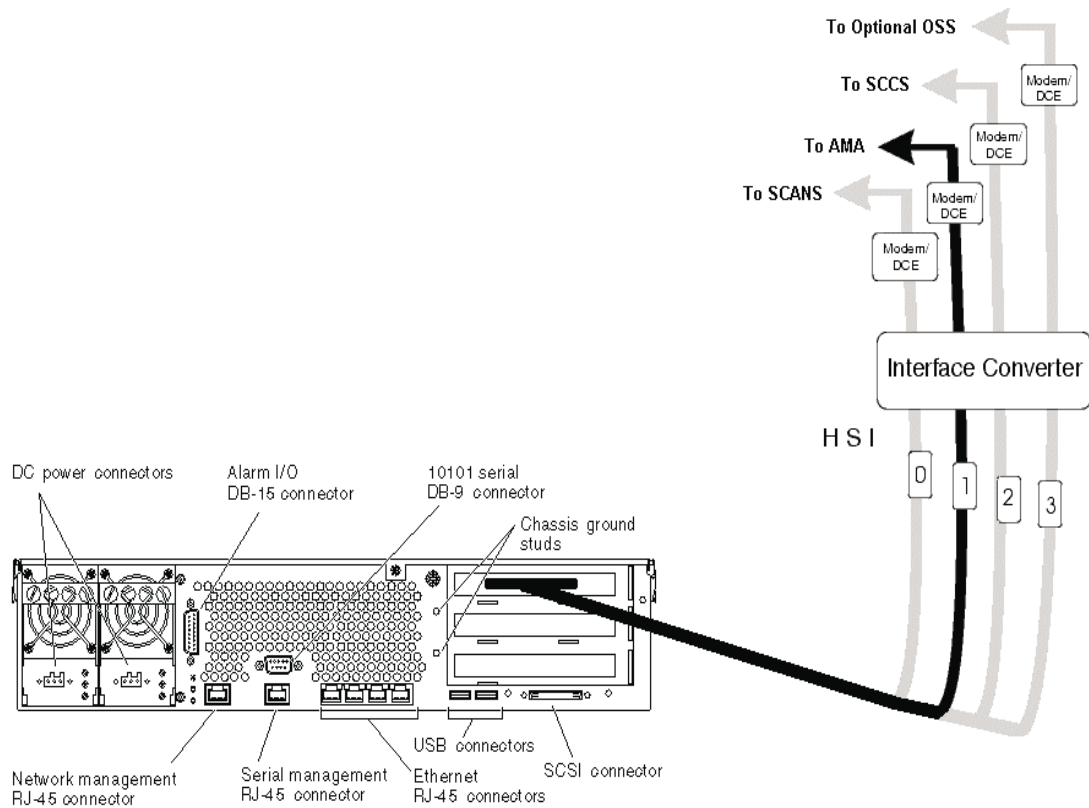

Figure 8.8-3 — AMA Data Link Hardware Installation (Netra 240)

5. Restore SDL13 to service.
 - (a) At MCC, type and enter the appropriate message:
RST:SDL=13
Response: RST SDL13 COMPLETED
 - (b) Enter CARRIAGE RETURN
Response: FORM INSERTED
 - (c) Type and enter: <
Response: Exit the sdladd form.
 - (d) Type and enter: <
Response: Exit this recent change session.
6. Backup Incore ECD to disk.
 - (a) At MCC, do Steps **b** through **i**.

- (b) Type and enter: **199**
Response: RCV PARAMETER INFO page displayed with cursor at 1.
database_name
 - (c) Type and enter: **incore**
Response: 2. review only
 - (d) Type and enter: **n**
Response: 3. journaling
 - (e) Type and enter: *****
Response: UNIX RTR (ODIN) - Data Entry page displayed.
 - (f) Type and enter: **activate**
Response: activate form displayed with cursor at 1. copy_inc_to_disk:
 - (g) Type and enter: **y**
Response: ODIN will request the action desired.
 - (h) Type and enter: **e**
Response: ODIN will return to the UNIX RTR (ODIN) - Data Entry page.
 - (i) Type and enter: **<**
Response: RCV MENU RCV ECD COMPLETED
7. Backup Office Dependent Data.
- Note:** Prior to the response there will be completed responses for the switching module and the AM.
- a. At MCC, type and enter: **BKUP:ODD**
Response: **BKUP ODD COMPLETED**
- It is recommended that primary disk be backed up and that a shelf copy of the disks be made.
8. Go to MCC display page 113 and verify that the data link shows up there.
9. **STOP. YOU HAVE COMPLETED THIS PROCEDURE.**

8.9 Perform SCC Data Link Growth

PROCEDURE

8.9.1 Start 3BSCC Process if not Already Started

1. At the MCC keyboard, if the *UNIX*¹ console is not displayed, hold down <ctrl> and press the Enter.
2. Log in to the *UNIX* console with the *UNIX* RTR login.
3. Enter `ps -ef | grep 3bscc`
Response: `root XXXX XXXX 0 11:07:40 ?0:10 3bscc 2`
`XXXX XXXX` is the process number.
4. If you receive the response above, proceed to Procedure 8.9.2. If you don't receive the above response, continue with the next step.
5. Enter `cd /opt/ATT3bem/var`
Response: `#`
6. Enter `pwd`
Response: `/opt/ATT3bem/var`
7. Change the UNEQ to EQIP:
 1. Enter `vi em_scc`
 2. Enter `w`
 3. Enter `cw`
 4. Enter `EQIP`
 5. Press the <Esc>
 6. Enter `:wq`
8. Enter `pg em_scc`
Response: `scc_link EQIP`
9. Enter `/etc/init.d/att3bem stop`
Response: `#`
10. Enter `/etc/init.d/att3bem start`
Response: `#`
11. Enter `ps -ef | grep 3bscc`
Response: `root XXXX XXXX 0 11:07:40 ? 0:10 3bscc 2`
`XXXX XXXX` is the process number.
12. **STOP. YOU HAVE COMPLETED THIS PROCEDURE.**

1. Trademark of SUN Microsystems, Inc.

8.9.2 SCC Data Link Growth

1. Type and enter: **incore**
Response: 2. review only
2. Type and enter: **n**
Response: 3. journaling
3. Type and enter: *****
Response: Enter Form Name:
4. Type and enter: **toggle**
Response: Enter Form Name:
High-level mode displayed.
5. Type and enter: **sdladd**
Response: 1. sdl_name
6. Type and enter: **SCC** or **SDL1**
Response: 2. port
7. Type and enter: **2**
Response: 3. ama_baud_rate
8. Enter CARRIAGE RETURN
Note: This field does not apply for SDL1.
Response: Enter Insert, Change . . .
9. Type and enter: **i**
The low-level forms will now be added automatically.
Response: 1. sdl_name
10. Type and enter: **<**
Response: Enter Form Name:
11. Type and enter: **<**
Response: Exit this recent change session.
12. To verify SDL1 has been inserted, view the **113** page. SDL1 should appear on this page.
Note 1: To save the incore ECD changes made in Steps **1** through **11**, execute Steps **16** through **23**, otherwise continue with Step **13**.
Note 2: SCC must also be grown into the MIN ECD. Execute Steps **13** through **15** to test the MIN ECD growth capability.
13. Type and enter: **199**
Response: RCV PARAMETER INFO page displayed with cursor at 1.
database_name
14. Type and enter: **rootdmly**
Response: 2. review only

15. Repeat Steps 2 through 11.
16. Save Incore ECD changes to disk:
Type and enter: **199**
Response: RCV PARAMETER INFO page displayed with cursor at 1.
database_name
17. Type and enter: **incore**
Response: 2. review only
18. Type and enter: **n**
Response: 3. journaling
19. Type and enter: *****
Response: Enter Form Name:
20. Type and enter: **activate**
Response: 1. copy_inc_to_disk:
21. Enter CARRIAGE RETURN
Response: Enter Execute, Change. . .
22. Type and enter: **e**
Response: Enter Form Name:
23. Type and enter: **<**
Response: Exit this recent change session.
 - (a) Install the SCC data link. The SCC data link consists of a dataset and cable connected to the High Speed Bus controller interface. (Figures 8.9-1 , 8.9-2 and 8.9-3 provide an illustration of the hardware connections for the SCC data link.)

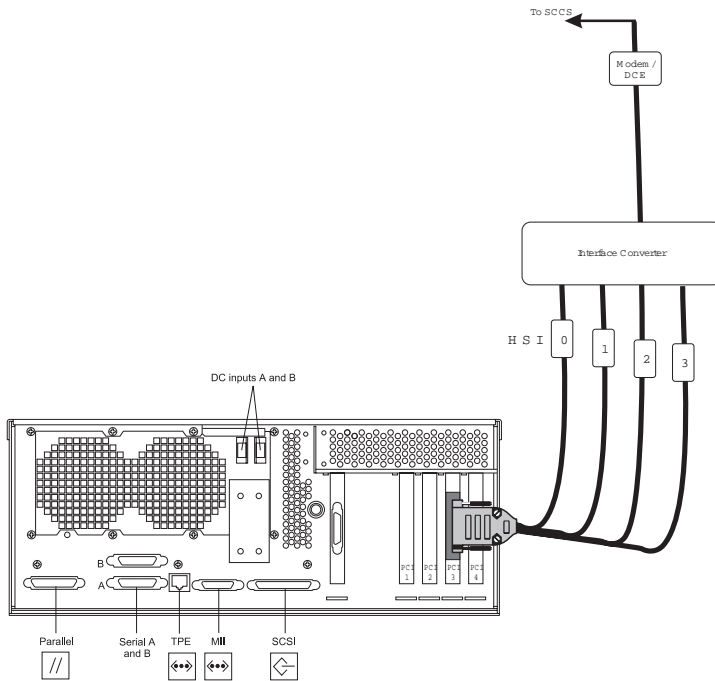

Figure 8.9-1 — SCC Data Link Hardware Connection (*Netra² t 1120*)

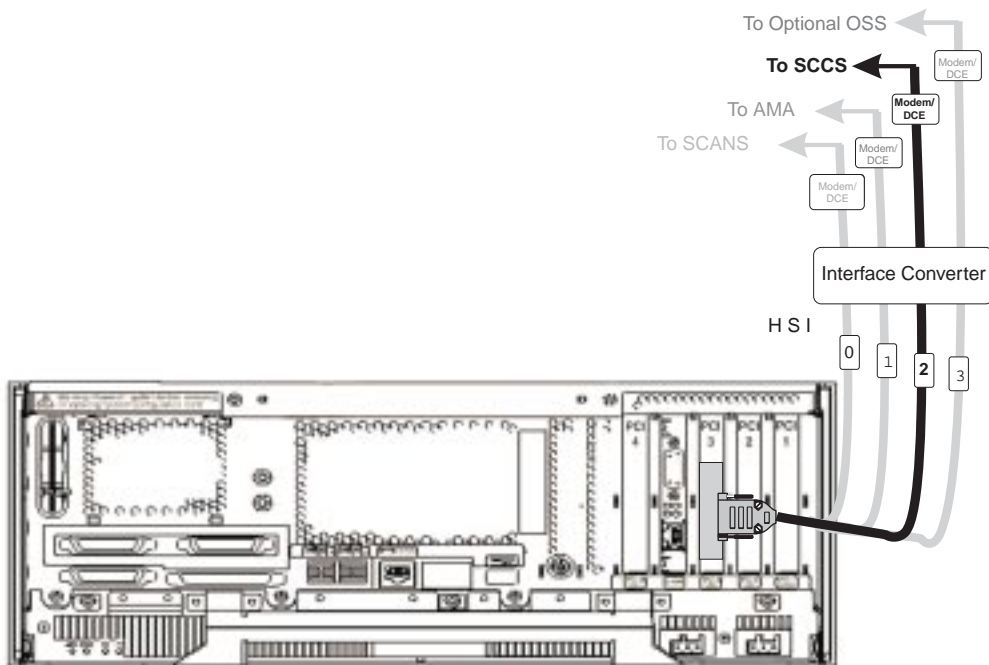

Figure 8.9-2 — SCC Data Link Hardware Connection (*Netra 20*)

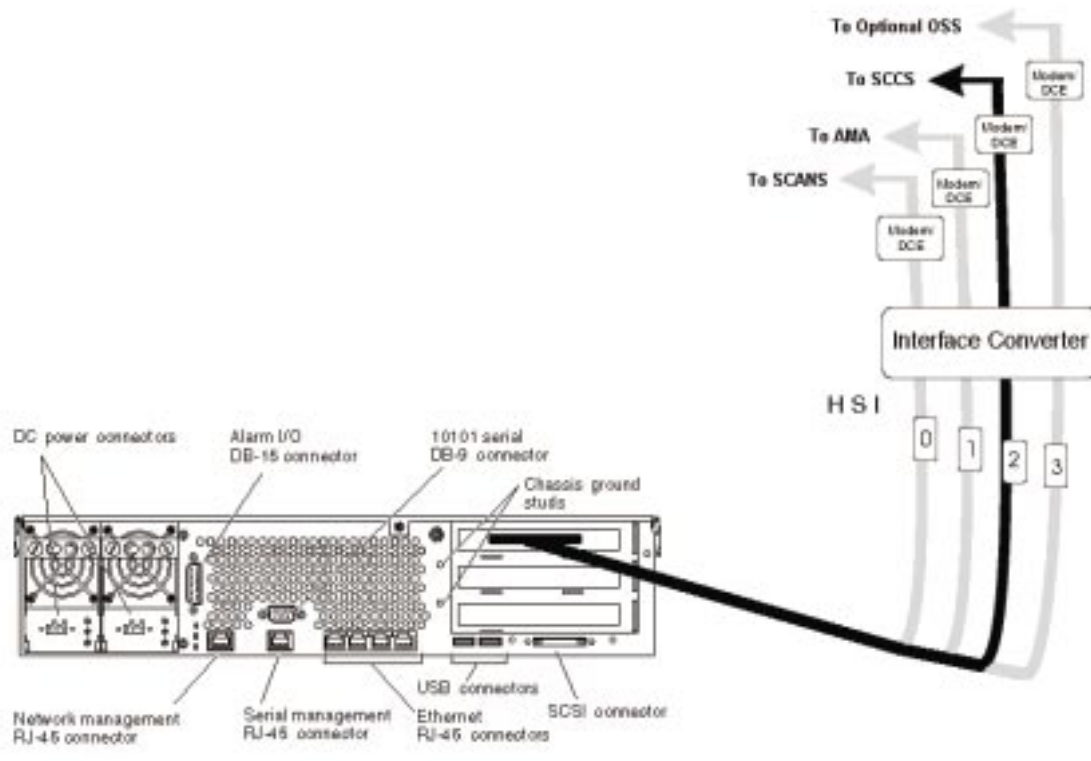

Figure 8.9-3 — SCC Data Link Hardware Connection (Netra 240)

24. Restore SDL1 to service:
At MCC, type and enter: **RST:SDL=1**
Response: RST SDL 1 COMPLETED
25. Restart ULARP processes:
At MCC, type and enter: **INIT:ULARP**
Response: INIT ULARP COMPLETED
26. **STOP. YOU HAVE COMPLETED THIS PROCEDURE.**

8.10 Perform ConnectVu (ATPRC) Data Link Growth

PROCEDURE

1. Type and enter: **incore**
Response: **2. review only**
2. Type and enter: **n**
Response: **3. journaling**
3. Type and enter: *****
Response: **Enter Form Name:**
4. Type and enter: **toggle**
Response: **Enter Form Name:**
High-level mode displayed.
5. Type and enter: **sdladd**
Response: **1. sdl_name**
6. Type and enter: **ATPRC** or **SDL6**
Response: **2. port**
7. Type and enter: **3**
Response: **3. ama_baud_rate**
8. Enter CARRIAGE RETURN.
Note: This field does not apply for SDL6.
Response: Enter Insert, Change . . .
9. Type and enter: **i**
The low-level forms will now be added automatically.
Response: **1. sdl_name**
10. Type and enter: **<**
Response: **Enter Form Name:**
11. Type and enter: **<**
Response: Exit this recent change session.
12. To verify SDL6 has been inserted, view the **113** page. SDL6 should appear on this page.
13. Save Incore ECD changes to disk:
Type and enter: **199**
Response: **RCV PARAMETER INFO** page displayed with cursor at **1. database_name**
14. Type and enter: **incore**
Response: **2. review only**

15. Type and enter: **n**
Response: **3. journaling**
16. Type and enter: *****
Response: **Enter Form Name:**
17. Type and enter: **activate**
Response: **1. copy_inc_to_disk:**
18. Enter CARRIAGE RETURN.
Response: Enter Execute, Change. . .
19. Type and enter: **e**
Response: **Enter Form Name:**
20. Type and enter: **<**
Response: Exit this recent change session.
 - (a) Install the ATPRC Data Link. The ATPRC Data Link consists of a dataset and cable connected to the High Speed Bus controller interface. (Figures 8.10-1, 8.10-2 and 8.10-3 provide an illustration of the hardware connection information for the ATPRC Data Link.)

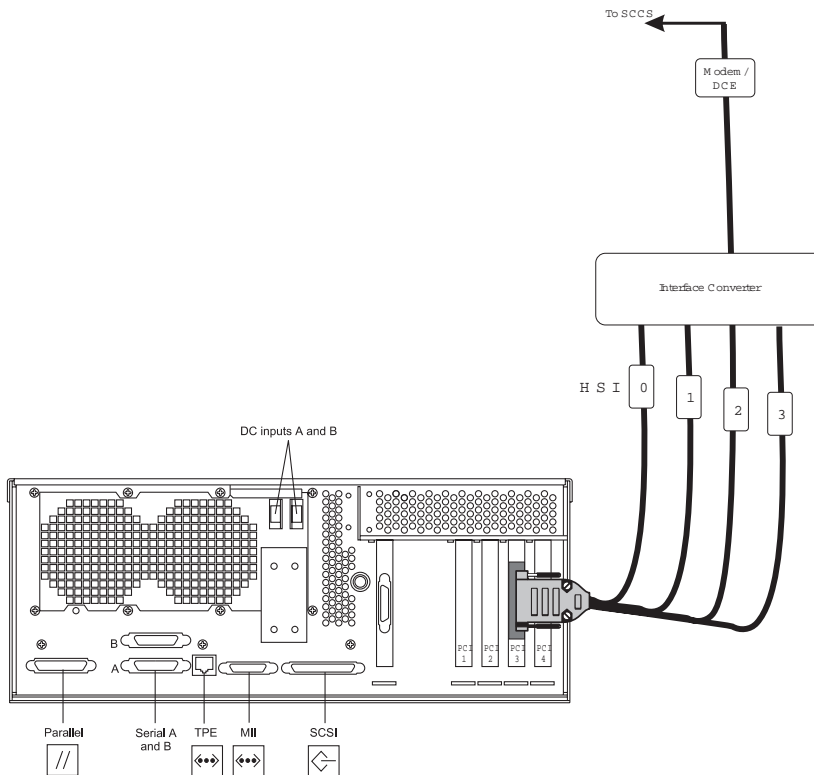

Figure 8.10-1 — ATPRC Data Link Hardware Connection (*Netra*¹ t 1120)

1. Trademark of Sun Microsystems, Inc.

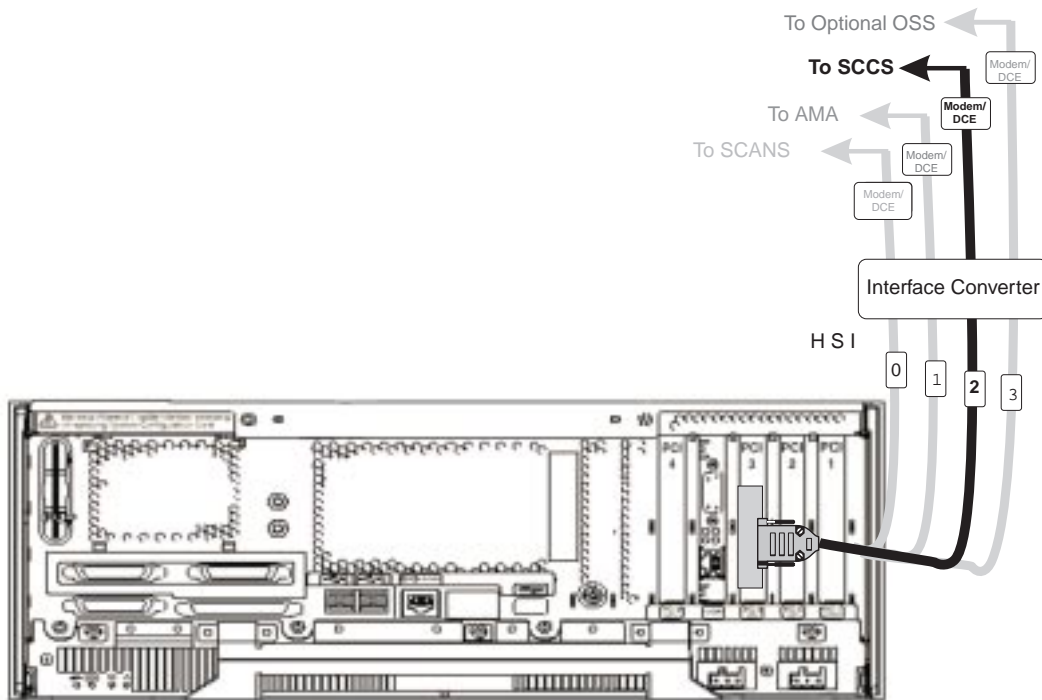

Figure 8.10-2 — ATPRC Data Link Hardware Connection (Netra 20)

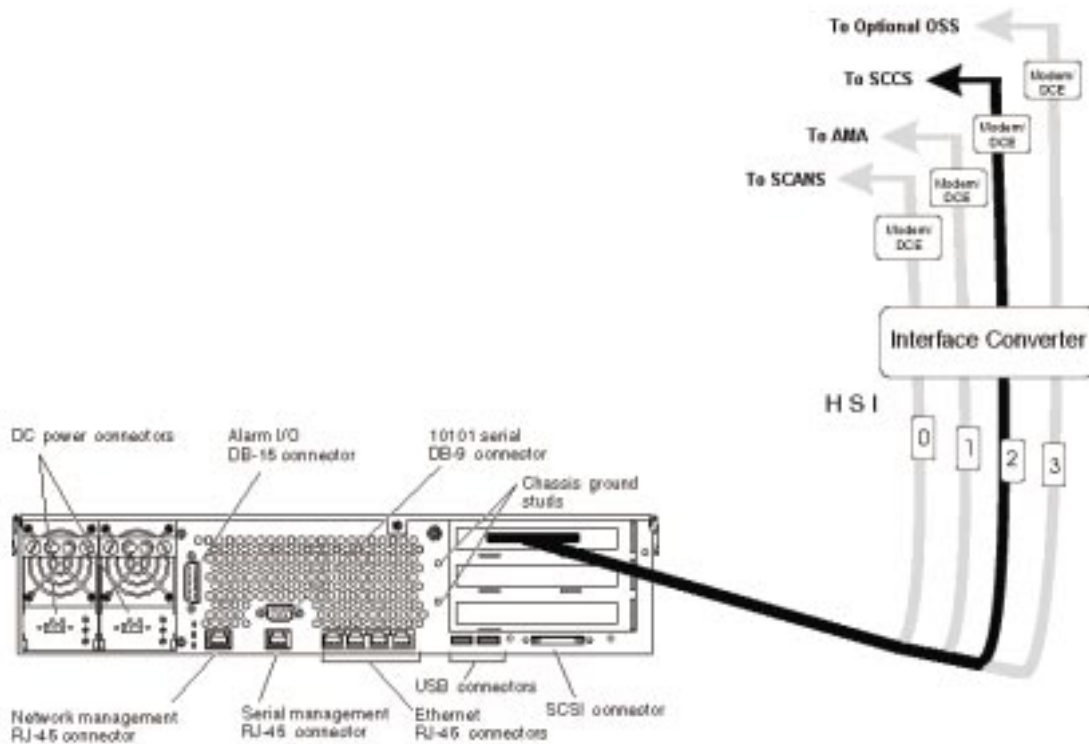

Figure 8.10-3 — ATPRC Data Link Hardware Connection (Netra 240)

21. Restore SDL6 to service:
At MCC, type and enter: **RST:SDL=6**
Response: **RST SDL 6 COMPLETED**
22. Execute a **54** on the MCC EIA page to allow the Data Link to be restored to ACT
23. **STOP. YOU HAVE COMPLETED THIS PROCEDURE.**

8.11 Perform TDMS/EADAS Data Link Growth

OVERVIEW

This procedure is used to grow in the Traffic Data Management System/Engineering and Administrative Data Acquisition System (TDMS/EADAS) BX.25 data link using ECD low-level forms. The TDMS/EADAS data link supports Lucent's TDMS operations system that is used to collect traffic data from the switch.

This procedure assumes the TDMS/EADAS link is to be grown on port 3 of the DRM's high speed interface (HSI). This procedure also assumes that the SCANS link is on HSI port 0 and the AMA link is on HSI port 1. This procedure makes adjustments based on whether the optional SCC data link is grown in on HSI port 2.

The following hardware must be on site:

- RS422 to RS232 converter (Black Box part # IC456A)
- RS422 cable (Black Box part # EDN37J-00XX-MM; where XX is the cable length in feet)
- RS232 cable (Black Box part # ECM25C-0010-MM)

This procedure takes approximately 2 to 3 hours to complete.

PROCEDURE

1. This process is a combination of procedures. Perform these procedures in the order in which they are presented.
 1. "Grow in TDMS/EADAS Data Link in ECD," Procedure 8.11.1.
 2. "Update RC/V 8.1 for TDMS/EADAS Data Link," Procedure 8.11.2.
 3. "Connect Hardware for TDMS/EADAS Data Link," Procedure 8.11.3.
 4. "Define TDMS/EADAS Port on TDMS System," Procedure 8.11.4.
 5. "Initialize TDMS/EADAS Processes," Procedure 8.11.5.
 6. "Restore TDMS/EADAS Data Link to Service," Procedure 8.11.6.
 7. "Verify Operation of TDMS/EADAS Data Link," Procedure 8.11.7.
 8. "Backup Office Dependent Data", Procedure 8.11.8

8.11.1 Grow in TDMS/EADAS Data Link in ECD

OVERVIEW

Warning: *ECD forms are case sensitive. Use capital letters where shown.*

PROCEDURE

1. **Grow in UCB for SDLC3**

At MCC, type and enter: **199** to access ECD RC/V.

Response: RCV PARAMETER INFO page displayed with cursor at 1.
database_name

2. Type and enter: **incore**

Response: 2. review only

3. Type and enter: **n**

Response: 3. journaling

4. Type and enter: *****

Response: RCV INITIALIZATION IN PROGRESS message displayed. UNIX
RTR RCV (ODIN) - Data Entry page displayed. Cursor at Enter
Form Name:

5. Type and enter: **trbegin**

Response: Transaction Begin
1.tr_name: TRBEGIN

6. Enter CARRIAGE RETURN

Response: Enter Execute, Change. . .

7. Type and enter: **e**

8. Type and enter: **ucb**

Response: Enter Database Operation
I=Insert, R=Review, U=Update, D=Delete

9. Type and enter: **i**

10. Populate the fields of the UCB record according to the following UCB form:

```
ucb          (1/4)
Information About Each Physical Device      (Recent Change and Verify)

  1.k_complex_name:_____  2.k_complex_number:____
  3.k_unit_name:SDLC      4.k_unit_number:3
ucb_type  5.essential:Never  6.top:n      7.unique_unit:y
  8.pseudo_node:n  9.restorable:y  10.removable:y
11.device_port:EMUDL  12.device_type:SDLC
13.internal_device:3  14.plant:y
15.critical:y  16.portswitch:n  17.posswitch:
```

```
ucb      (2/4)

  minor_device_status      18.boot:n      19.rexinh:n      20.errlog:n

  21.major_status:UNEQIP   22.equipage:

  23.device_num:6         24.channel_num:11

  25.hv:_____ 26.mt:_____ 27.mv:_____

  28.interrupt_num:      29.service_intrpt:___

  30.pathname:pu/sdlc

  31.location
    32.floor:1      33.aisle:a      34.plate:1      35.pack:1
```

```
ucb      (3/4)

  complex_name  complex_number  unit_name  unit_number
  36.down  37)_____ 38)____ 39)_____ 40)____

  41.side  42)_____ 43)____ 44)_____ 45)____

  46.cntrl_0  47)_____ 48)____ 49)___IOP___ 50)___2_

  51.cntrl_1  52)_____ 53)____ 54)_____ 55)____

  56.error_table:ioperr  57.option_name:

  58.pcid:3__ 59.pcsdid:0 60.h_type:___

  61.handler_id:sdl
```

```
ucb      (4/4)

  62.packcode:t075 63.issue:___ 64.version:

  65.cvaddr:0x5517 66.u_model:
```

11. After updating field 65 on the UCB form, enter CARRIAGE RETURN twice.
Response: Enter Insert, Change, Substitute, Validate, screen#, or Print:
12. Type and enter: **i**
Response: FORM INSERTED
13. Complete steps 14-30 if the SCC data link is not equipped on HSI port 2.
Otherwise, if the SCC data link is equipped on HSI port 2, skip to step 31.
14. **Warning: Only execute steps 14-30 if no data link is provisioned on HSI port 2.**
Type and enter: **<**
Response: Enter Form Name:
15. Type and enter: **ucb**
Response: Enter Database Operation
I=Insert, R=Review, U=Update, D=Delete

16. Type and enter: **u** and enter CARRIAGE RETURN twice.
Response: Cursor at K_UNIT_NAME
17. Type and enter: **SDLC**
Response: Cursor at K_UNIT_NUMBER
18. Type and enter: **1**
Response: Reading...
19. Type and enter: **3** to view screen # 3.
20. Type and enter: **c** to change a field.
Response: Cursor at Change field:
21. Type and enter: **44**
22. Type and enter: **SDLC**
Response: Cursor at Change field:
23. Type and enter: **45**
24. Type and enter: **3** and then enter a CARRIAGE RETURN
Response: Enter Database Operation
I=Insert, R=Review, U=Update, D=Delete
25. Type and enter: **u** to update the ucb record.
Response: FORM UPDATED
26. Type and enter: **<**
Response: Cursor at Enter Form Name:
27. Type and enter: **trend**
Response: 1. tr_name: TREND
2. dis_cf_checks:n
3. apply_tr:y
4. o_missing_links:n
28. Enter CARRIAGE RETURN 4 times.
Response: Enter Execute, Change. . .
29. Type and enter: **e**
Response: Executing
Enter Form Name:
30. Go to "Update UCB for SDLC3 to GROW State," Step **47**.
31. **Warning: Only execute steps 31-46 if a data link is provisioned on HSI port 2.**
Type and enter: **<**
Response: Enter Form Name:
32. Type and enter: **ucb**
Response: Enter Database Operation
I=Insert, R=Review, U=Update, D=Delete

33. Type and enter: **u** and enter CARRIAGE RETURN twice.
Response: Cursor at K_UNIT_NAME
34. Type and enter: **SDLC**
Response: Cursor at K_UNIT_NUMBER
35. Type and enter: **2**
Response: Reading...
36. Type and enter: **3** to view screen # 3.
37. Type and enter: **c** to change a field.
Response: Cursor at Change field:
38. Type and enter: **44**
39. Type and enter: **SDLC**
Response: Cursor at Change field:
40. Type and enter: **45**
41. Type and enter: **3** and then enter a CARRIAGE RETURN
Response: Enter Database Operation
I=Insert, R=Review, U=Update, D=Delete
42. Type and enter: **u** to update the ucb record.
Response: FORM UPDATED.
43. Type and enter: **<**
Response: Cursor at Enter Form Name:
44. Type and enter: **trend**
Response: 1. tr_name: TREND
2. dis_cf_checks:n
3. apply_tr:y
4. o_missing_links:n
45. Enter CARRIAGE RETURN 4 times.
Response: Enter Execute, Change. . .
46. Type and enter: **e**
Response: Executing
Enter Form Name:
47. **Update UCB for SDLC3 to GROW State**
Type and enter: **trbegin**
Response: Transaction Begin
1.tr_name: TRBEGIN
48. Enter CARRIAGE RETURN
Response: Enter Execute, Change. . .
49. Type and enter: **e**

50. Type and enter: **ucb**
Response: Enter Database Operation
I=Insert, R=Review, U=Update, D=Delete
51. Type and enter: **u** and enter CARRIAGE RETURN twice.
Response: Cursor at K_UNIT_NAME
52. Type and enter: **SDLC**
Response: Cursor at K_UNIT_NUMBER
53. Type and enter: **3**
Response: Reading...
54. Type and enter: **2** to view screen # 2.
55. Type and enter: **c** to change a field.
Response: Cursor at Change field:
56. Type and enter: **21** to change the MAJOR_STATUS field.
57. Type and enter: **GROW** and then enter CARRIAGE RETURN
Response: Enter Database Operation
I=Insert, R=Review, U=Update, D=Delete
58. Type and enter: **u** to update the ucb record.
Response: FORM UPDATED.
59. Type and enter: **<**
Response: Cursor at Enter Form Name:
60. Type and enter: **trend**
Response: 1. tr_name: TREND
2. dis_cf_checks:n
3. apply_tr:y
4. o_missing_links:n
61. Enter CARRIAGE RETURN 4 times.
Response: Enter Execute, Change. . .
62. Type and enter: **e**
Response: Executing
Enter Form Name:
63. **Insert UCB and CPBLX3 for SDL3 and Update SDLC3 to Down Reference Sidle**
Type and enter: **trbegin**
Response: Transaction Begin
1.tr_name: TRBEGIN
64. Enter CARRIAGE RETURN
Response: Enter Execute, Change. . .
65. Type and enter: **e**

66. Type and enter: **ucb**

Response: Enter Database Operation
I=Insert, R=Review, U=Update, D=Delete

67. Type and enter: **i**

68. Populate the fields of the UCB record according to the following UCB form:

```
ucb      (1/4)
Information About Each Physical Device      (Recent Change and Verify)

1.k_complex_name:_____ 2.k_complex_number:____
3.k_unit_name:SDL 4.k_unit_number:3
ucb_type 5.essential:NEVER 6.top:n 7.unique_unit:y
8.pseudo_node:n 9.restorable:y 10.removable:y
11.device_port:EMUDL 12.device_type:SDL
13.internal_device:2 14.plant:y
15.critical:y 16.portswitch:n 17.posswitch:
```

```
ucb      (2/4)

minor_device_status 18.boot:n 19.rexinh:n 20.errlog:n
21.major_status:UNEQIP 22.equipage:
23.device_num:6 24.channel_num:11
25.hv:_____ 26.mt:_____ 27.mv:_____
28.interrupt_num: 29.service_intrpt:___
30.pathname:pu/sdl
31.location
32.floor:1 33.aisle:a 34.plate:1 35.pack:1
```

```
ucb      (3/4)

complex_name complex_number unit_name unit_number
36.down 37)_____ 38)___ 39)_____ 40)___
41.side 42)_____ 43)___ 44)_____ 45)___
46.cntrl_0 47)_____ 48)___ 49)_SDLC___ 50)_3__
51.cntrl_1 52)_____ 53)___ 54)_____ 55)___
56.error_table:ioperr 57.option_name:cpblx33
58.pcid:_3__ 59.pcsdid:2 60.h_type:___
61.handler_id:sdl
```

```
ucb          (4/4)
62.packcode:____ 63.issue:___ 64.version:___
65.cvaddr:_____ 66.u_model:
```

69. After updating field 59 on the UCB form, enter CARRIAGE RETURN or > until the following response is observed.

Response: Enter Insert, Change, Substitute, Validate, screen#, or Print:

70. Type and enter: **i**

Response: FORM INSERTED

71. Type and enter: **<**

Response: Enter Form Name:

72. Type and enter: **cpblx3**

Response: Enter Database Operation
I=Insert, R=Review, U=Update, D=Delete

73. Type and enter: **i**

74. Populate the fields of the CPBLX3 record according to the following CPBLX3 form.

Note 1: Field 2 (speed) should be set to the required baud rate of 110, 300, 1200, 2400, 4800, 9600, 56000, or 64000.

Note 2: There is a version of this form, which does not display the CAUTION at the top of the screen. As a result, the screen layout will differ slightly from the screens shown in this step. Make sure that the correct fields are being updated with the data shown in this step.

```
cpblx3      (1/5)
Communications Protocol Option Block      (Recent Change and Verify)
THESE ARE CRITICAL SYSTEM PARAMETERS!!  CHANGE WITH EXTREME CAUTION. See Note 2
  1.option_name:cpblx33
  2.speed: "See Note 1"  3.duplex:full  4.ds_type:2024A
  5.carrier:c  6.line_access:private  7.mode_op:b
  8.pdtime1:60  9.pdtime2:100  10.window:4
 11.rexmit:7  12.dcedte:0  13.pcsd_stat:active
 14.config:simplex
```

```
cpblx3      (2/5)
THESE ARE CRITICAL SYSTEM PARAMETERS!!  CHANGE WITH EXTREME CAUTION. See Note 2

  15.ldtel      sid      tlim      telno
1) _____  _____  _____  _____
2) _____  _____  _____  _____
3) _____  _____  _____  _____
4) _____  _____  _____  _____

  19.security:n      20.link_id:0
  21.feid_len:0      22.neid_len:0      23.password_len:0
```

```
cpblx3      (3/5)
THESE ARE CRITICAL SYSTEM PARAMETERS!!  CHANGE WITH EXTREME CAUTION. See Note 2

  24.feid.fend
1) _____ 4) _____ 7) _____ 10) _____ 13) _____
2) _____ 5) _____ 8) _____ 11) _____ 14) _____
3) _____ 6) _____ 9) _____ 12) _____ 15) _____

  35.neid.nend
1) _____ 4) _____ 7) _____ 10) _____ 13) _____
2) _____ 5) _____ 8) _____ 11) _____ 14) _____
3) _____ 6) _____ 9) _____ 12) _____ 15) _____
```

```
cpblx3      (4/5)
THESE ARE CRITICAL SYSTEM PARAMETERS!!  CHANGE WITH EXTREME CAUTION. See Note 2

  46.pswrd.pwrđ
1) _____ 4) _____ 7) _____ 10) _____ 13) _____
2) _____ 5) _____ 8) _____ 11) _____ 14) _____
3) _____ 6) _____ 9) _____ 12) _____ 15) _____

  57.perm_state:allow      58.outscrsiz:4062      59.outpktsiz:259      60.inscrsiz:4062
  61.inpktsiz:259      62.hup:n      63.spckt:0      64.x3wsize:2      65.x3psize:256
```

```
cpblx3      (5/5)
THESE ARE CRITICAL SYSTEM PARAMETERS!!  CHANGE WITH EXTREME CAUTION. See Note 2

  66.x3pvcn.lđinno
1) _____ 6) _____ 11) _____ 16) _____ 21) _____ 26) _____ 31) _____
2) _____ 7) _____ 12) _____ 17) _____ 22) _____ 27) _____ 32) _____
3) _____ 8) _____ 13) _____ 18) _____ 23) _____ 28) _____
4) _____ 9) _____ 14) _____ 19) _____ 24) _____ 29) _____
5) _____ 10) _____ 15) _____ 20) _____ 25) _____ 30) _____

  81.time_ti:180      82.time_tj:60      83.time_tf:60      84.time_t1:60
  85.time_td:180      86.time_ts:180      87.time_ack:5
```

- 75. After updating field 87 on the UCB form, enter CARRIAGE RETURN
Response: Enter Insert, Change, Substitute, Validate, screen#, or Print:
- 76. Type and enter: i
Response: FORM INSERTED

77. Type and enter: <
Response: Enter Form Name:
78. Type and enter: **ucb**
Response: Enter Database Operation
I=Insert, R=Review, U=Update, D=Delete
79. Type and enter: **u** and enter CARRIAGE RETURN twice.
Response: Cursor at K_UNIT_NAME
80. Type and enter: **SDLC**
Response: Cursor at K_UNIT_NUMBER
81. Type and enter: **3**
Response: Reading...
82. Type and enter: **3** to view screen # 3.
83. Type and enter: **c** to change a field.
Response: Cursor at Change field:
84. Type and enter: **39**
85. Type and enter: **SDL**
Response: Cursor at Change field:
86. Type and enter: **40**
87. Type and enter: **3** and then enter a CARRIAGE RETURN
Response: Enter Database Operation
I=Insert, R=Review, U=Update, D=Delete
88. Type and enter: **u** to update the ucb record.
Response: FORM UPDATED
89. Type and enter: <
Response: Cursor at Enter Form Name:
90. Type and enter: **trend**
Response: 1. tr_name: TREND
2. dis_cf_checks:n
3. apply_tr:y
4. o_missing_links:n
91. Enter CARRIAGE RETURN 4 times.
Response: Enter Execute, Change. . .
92. Type and enter: **e**
Response: Executing
Enter Form Name:
93. **Insert MDCT, LOGDEV, and ULARP Forms**

- Type and enter: **trbegin**
Response: Transaction Begin
1.tr_name: TRBEGIN
94. Enter CARRIAGE RETURN
Response: Enter Execute, Change. . .
95. Type and enter: **e**
Response: FORM EXECUTED
96. Type and enter: **mdct**
Response: Enter Database Operation
I=Insert, R=Review, U=Update, D=Delete
97. Type and enter: **i**
98. Populate the fields of the MDCT record according to the following MDCT form.
- Note:** In the following form, Field 3 (mdct_type) is set to the lower case letter l, and Field 4 (mdct_id_char) is set to the number 1.

```
mdct      (1/3)
Logical To Physical Device Transaction      (Recent Change and Verify)

  1.mdct_name:EADAS      2.logical_device:io

  3.mdct_type:l      4.mdct_id_char:1

  5.active_devices
6.complex_name  7.complex_number  8.unit_name  9.unit_number
1)_____      _____      _____      _____
2)_____      _____      _____      _____
3)_____      _____      _____      _____
4)_____      _____      _____      _____
```

```
mdct      (2/3)

 10.backup_devices
11.complex_name 12.complex_number 13.unit_name 14.unit_number
1)_____      _____      _____      _____
2)_____      _____      _____      _____
3)_____      _____      _____      _____
4)_____      _____      _____      _____

 15.spare_devices
16.complex_name 17.complex_number 18.unit_name 19.unit_number
1)_____      _____      _____      _____
2)_____      _____      _____      _____
3)_____      _____      _____      _____
4)_____      _____      _____      _____
```

```
mdct      (3/3)

  20.oos_devices
21.complex_name  22.complex_number  23.unit_name  24.unit_number
1) _____  _____  _____  _____
2) _____  _____  _____  _____
3) _____  _____  _____  _____
4) _____  _____  _____  _____

  25.gettyid:getty0
```

99. After updating field 25 on the MDCT form, enter CARRIAGE RETURN
Response: Enter Insert, Change, Substitute, Validate, screen#, or Print:
100. Type and enter: **i**
Response: FORM INSERTED
101. Type and enter: **<**
Response: Enter Form Name:
102. Type and enter: **logdev**
Response: Enter Database Operation
I=Insert, R=Review, U=Update, D=Delete
103. Type and enter: **i**
104. Populate the fields of the first LOGDEV record according to the following LOGDEV form.

```
logdev      (1/1)
Logical Device Information      (Recent Change and Verify)

  1.logical_name:/dev/eadlo      2.partition:0x2
  3.mdct_name:EADAS      4.channel_id:___
  5.dcn:23      6.driver_type:c
  7.gettyid:_____      8.usr:rw-
  9.grp:rw-      10.other:---
```

105. After updating field 9 on the LOGDEV form, enter CARRIAGE RETURN until the following response is observed.
Response: Enter Insert, Change, Substitute, Validate, screen#, or Print:
106. Type and enter: **i**
Response: FORM INSERTED
107. Populate the fields of the second LOGDEV record according to the following LOGDEV form.

```
logdev      (1/1)
Logical Device Information      (Recent Change and Verify)

  1.logical_name:/dev/eadmed    2.partition:0x3
  3.mdct_name:EADAS           4.channel_id:___
  5.dcn:23                    6.driver_type:c
  7.gettyid:_____           8.usr:rw-
  9.grp:rw-                   10.other:---
```

108. After updating field 9 on the LOGDEV form, enter CARRIAGE RETURN until the following response is observed.

Response: Enter Insert, Change, Substitute, Validate, screen#, or Print:

109. Type and enter: **i**

Response: **FORM INSERTED**

110. Populate the fields of the third LOGDEV record according to the following LOGDEV form.

```
logdev      (1/1)
Logical Device Information      (Recent Change and Verify)

  1.logical_name:/dev/eadhi    2.partition:0x1
  3.mdct_name:EADAS           4.channel_id:___
  5.dcn:23                    6.driver_type:c
  7.gettyid:_____           8.usr:rw-
  9.grp:rw-                   10.other:---
```

111. After updating field 9 on the LOGDEV form, enter CARRIAGE RETURN until the following response is observed.

Response: Enter Insert, Change, Substitute, Validate, screen#, or Print:

112. Type and enter: **i**

Response: **FORM INSERTED**

113. Type and enter: **<**

Response: Enter Form Name:

114. Type and enter: **ularp**

Response: Enter Database Operation
I=Insert, R=Review, U=Update, D=Delete

115. Type and enter: **i**

116. Populate the fields of the first ULARP record according to the following ULARP form.

```
ULARP ECD Record ularp      (1/1)
  (Recent Change and Verify)
1.rec_name:ECR3  2.exec_no:1710

3.child_priority:50  4.boot_prm:0x0    5.sleep:0
6.utilid:0x4e0  7.runttype:PROCESS  8.run_config:FULL
9.craft:n      10.cruc_craft:n    11.uniq_child:n    12.wait_for_run:n
13.proc_path:/no5text/as/ECr3
14.proc_args:_____
15.shell_cmd:
```

117. After updating field 13 on the ULARP form, enter CARRIAGE RETURN until the following response is observed.

Response: Enter Insert, Change, Substitute, Validate, screen#, or Print:

118. Type and enter: i

Response: FORM INSERTED

119. Populate the fields of the second ULARP record according to the following ULARP form.

```
ULARP ECD Record ularp      (1/1)
  (Recent Change and Verify)
1.rec_name:ECR4  2.exec_no:1715

3.child_priority:50  4.boot_prm:0x0    5.sleep:0
6.utilid:0x4f0  7.runttype:PROCESS  8.run_config:FULL
9.craft:n      10.cruc_craft:n    11.uniq_child:n    12.wait_for_run:n
13.proc_path:/no5text/as/ECr4
14.proc_args:_____
15.shell_cmd:
```

120. After updating field 13 on the ULARP form, enter CARRIAGE RETURN until the following response is observed.

Response: Enter Insert, Change, Substitute, Validate, screen#, or Print:

121. Type and enter: i

Response: FORM INSERTED

122. Populate the fields of the third ULARP record according to the following ULARP form.

```
ULARP ECD Record ularp      (1/1)
  (Recent Change and Verify)
1.rec_name:ECR5  2.exec_no:1720

3.child_priority:50  4.boot_prm:0x0    5.sleep:0
6.utilid:0x780  7.runttype:PROCESS  8.run_config:FULL
9.craft:n      10.cruc_craft:n    11.uniq_child:n    12.wait_for_run:n
13.proc_path:/no5text/as/ECr5
14.proc_args:_____
15.shell_cmd:
```

123. After updating field 13 on the ULARP form, enter CARRIAGE RETURN until the following response is observed.

Response: Enter Insert, Change, Substitute, Validate, screen#, or Print:

124. Type and enter: i

Response: FORM INSERTED

125. Populate the fields of the fourth ULARP record according to the following ULARP form.

```
ULARP ECD Record ularp      (1/1)
  (Recent Change and Verify)
1.rec_name:ECR6  2.exec_no:1725

3.child_priority:50  4.boot_prm:0x0    5.sleep:0
6.utilid:0x781  7.runttype:PROCESS  8.run_config:FULL
9.craft:n      10.cruc_craft:n    11.uniq_child:n    12.wait_for_run:n
13.proc_path:/no5text/as/ECr6
14.proc_args:_____
15.shell_cmd:
```

126. After updating field 13 on the ULARP form, enter CARRIAGE RETURN until the following response is observed.

Response: Enter Insert, Change, Substitute, Validate, screen#, or Print:

127. Type and enter: i

Response: FORM INSERTED

128. Populate the fields of the fifth ULARP record according to the following ULARP form.

```
ULARP ECD Record ularp      (1/1)
  (Recent Change and Verify)
1.rec_name:ECAP  2.exec_no:1690

3.child_priority:50  4.boot_prm:0x0    5.sleep:0
6.utilid:0x4b0  7.runttype:PROCESS  8.run_config:FULL
9.craft:n      10.cruc_craft:n    11.uniq_child:n    12.wait_for_run:n
13.proc_path:/no5text/as/ECap
14.proc_args:_____
15.shell_cmd:
```

129. After updating field 13 on the ULARP form, enter CARRIAGE RETURN until the following response is observed.

Response: Enter Insert, Change, Substitute, Validate, screen#, or Print:

130. Type and enter: i

Response: FORM INSERTED

131. Populate the fields of the sixth ULARP record according to the following ULARP form.

```
ULARP ECD Record ularp      (1/1)
  (Recent Change and Verify)
1.rec_name:ECW3  2.exec_no:1735

3.child_priority:50  4.boot_prm:0x0    5.sleep:0
6.utilid:0x4e0  7.runttype:PROCESS  8.run_config:FULL
9.craft:n      10.cruc_craft:n    11.uniq_child:n    12.wait_for_run:n
13.proc_path:/no5text/as/ECw3
14.proc_args:_____
15.shell_cmd:
```

132. After updating field 13 on the ULARP form, enter CARRIAGE RETURN until the following response is observed.

Response: Enter Insert, Change, Substitute, Validate, screen#, or Print:

133. Type and enter: i

Response: FORM INSERTED

134. Populate the fields of the seventh ULARP record according to the following ULARP form.

```
ULARP ECD Record ularp      (1/1)
  (Recent Change and Verify)
1.rec_name:ECW4  2.exec_no:1740

3.child_priority:50  4.boot_prm:0x0    5.sleep:0
6.utilid:0x4f0  7.runttype:PROCESS  8.run_config:FULL
9.craft:n      10.cruc_craft:n    11.uniq_child:n    12.wait_for_run:n
13.proc_path:/no5text/as/ECw4
14.proc_args:_____
15.shell_cmd:
```

135. After updating field 13 on the ULARP form, enter CARRIAGE RETURN until the following response is observed.

Response: Enter Insert, Change, Substitute, Validate, screen#, or Print:

136. Type and enter: i

Response: FORM INSERTED

137. Populate the fields of the eighth ULARP record according to the following ULARP form.

```
ULARP ECD Record ularp      (1/1)
  (Recent Change and Verify)
1.rec_name:ECW5  2.exec_no:1745

3.child_priority:50  4.boot_prm:0x0    5.sleep:0
6.utilid:0x790  7.runttype:PROCESS  8.run_config:FULL
9.craft:n      10.cruc_craft:n    11.uniq_child:n    12.wait_for_run:n
13.proc_path:/no5text/as/ECw5
14.proc_args:_____
15.shell_cmd:
```

138. After updating field 13 on the ULARP form, enter CARRIAGE RETURN until the following response is observed.

Response: Enter Insert, Change, Substitute, Validate, screen#, or Print:

139. Type and enter: i

Response: FORM INSERTED

140. Populate the fields of the ninth ULARP record according to the following ULARP form.

```
ULARP ECD Record ularp      (1/1)
  (Recent Change and Verify)
  1.rec_name:ECW6  2.exec_no:1730

  3.child_priority:50  4.boot_prm:0x0    5.sleep:0
  6.utilid:0x781  7.runtype:PROCESS  8.run_config:FULL
  9.craft:n      10.cruc_craft:n    11.uniq_child:n    12.wait_for_run:n
  13.proc_path:/no5text/as/ECw6
  14.proc_args:_____
  15.shell_cmd:
```

141. After updating field 13 on the ULARP form, enter CARRIAGE RETURN until the following response is observed.

Response: Enter Insert, Change, Substitute, Validate, screen#, or Print:

142. Type and enter: **i**

Response: FORM INSERTED

143. Type and enter: **<**

Response: Cursor at Enter Form Name:

144. Type and enter: **trend**

Response: 1. tr_name: TREND
2. dis_cf_checks:n
3. apply_tr:y
4. o_missing_links:n

145. Enter CARRIAGE RETURN 4 times.

Response: Enter Execute, Change. . .

146. Type and enter: **e**

Response: Executing
Enter Form Name:

147. **Update UCB for SDL3 to GROW**

Type and enter: **trbegin**

Response: Transaction Begin
1.tr_name: TRBEGIN

148. Enter CARRIAGE RETURN

Response: Enter Execute, Change. . .

149. Type and enter: **e**

150. Type and enter: **ucb**

Response: Enter Database Operation
I=Insert, R=Review, U=Update, D=Delete

151. Type and enter: **u** and enter CARRIAGE RETURN twice.

Response: Cursor at K_UNIT_NAME

152. Type and enter: **SDL**
Response: Cursor at K_UNIT_NUMBER
153. Type and enter: **3**
Response: Reading...
154. Type and enter: **2** to view screen # 2.
155. Type and enter: **c** to change a field.
Response: Cursor at Change field:
156. Type and enter: **21** to change the MAJOR_STATUS field.
157. Type and enter: **GROW** and enter CARRIAGE RETURN
Response: Enter Database Operation
I=Insert, R=Review, U=Update, D=Delete
158. Type and enter: **u** to update the ucb record.
Response: FORM UPDATED
159. Type and enter: **<**
Response: Cursor at Enter Form Name:
160. Type and enter: **trend**
Response: 1. tr_name: TREND
2. dis_cf_checks:n
3. apply_tr:y
4. o_missing_links:n
161. Enter CARRIAGE RETURN 4 times.
Response: Enter Execute, Change. . .
162. Type and enter: **e**
Response: Executing
Enter Form Name:
163. **Update UCB for SDLC3 and SDL3 to OOS State**
Type and enter: **trbegin**
Response: Transaction Begin
1.tr_name: TRBEGIN
164. Enter CARRIAGE RETURN
Response: Enter Execute, Change. . .
165. Type and enter: **e**
166. Type and enter: **ucb**
Response: Enter Database Operation
I=Insert, R=Review, U=Update, D=Delete
167. Type and enter: **u** and enter CARRIAGE RETURN twice.
Response: Cursor at K_UNIT_NAME

168. Type and enter: **SDLC**
Response: Cursor at K_UNIT_NUMBER
169. Type and enter: **3**
Response: Reading...
170. Type and enter: **2** to view screen # 2.
171. Type and enter: **c** to change a field.
Response: Cursor at Change field:
172. Type and enter: **21** to change the MAJOR_STATUS field.
173. Type and enter: **OOS** and enter CARRIAGE RETURN
Response: Enter Database Operation
I=Insert, R=Review, U=Update, D=Delete
174. Type and enter: **u** to update the ucb record.
Response: FORM UPDATED.
175. Type and enter: **SDL** and enter CARRIAGE RETURN twice.
Response: Cursor at K_UNIT_NUMBER
176. Type and enter: **3**
Response: Reading...
177. Type and enter: **2** to view screen # 2.
178. Type and enter: **c** to change a field.
Response: Cursor at Change field:
179. Type and enter: **21** to change the MAJOR_STATUS field.
180. Type and enter: **OOS** and enter CARRIAGE RETURN
Response: Enter Database Operation
I=Insert, R=Review, U=Update, D=Delete
181. Type and enter: **u** to update the ucb record.
Response: FORM UPDATED.
182. Type and enter: **<**
Response: Cursor at Enter Form Name:
183. Type and enter: **trend**
Response: 1. tr_name: TREND
2. dis_cf_checks:n
3. apply_tr:y
4. o_missing_links:n
184. Enter CARRIAGE RETURN 4 times.
Response: Enter Execute, Change. . .
185. Type and enter: **e**
Response: Executing
Enter Form Name:

186. Save ECD Changes to Disk

Type and enter: **activate** to save the ECD changes to disk.

Response: 1.copy_inc_to_disk:YES

187. Enter CARRIAGE RETURN

Response: Enter Execute, Change. . .

188. Type and enter: e

Response: Executing..

189. Type and enter: < to exit ECD RC/V.

190. THIS IS A SAFE STOPPING POINT, proceed to Procedure 8.11.2

8.11.2 Update RC/V 8.1 for TDMS/EADAS Data Link

PROCEDURE

1. At the MCC or STLWS, type and enter **196** to enter Recent Change and Verify.
Response: PRINT OPTION CR = N ___
DETAIL OPTION CR = N ___
VERBOSE OPTION CR = N ___
INPUT Y or N
2. Enter CARRIAGE RETURN 3 times to get to the RECENT CHANGE AND VERIFY CLASSES page.
3. Type and enter: **8.1u** to update recent change view 8.1.
Response: OFFICE PARAMETERS (MISCELLANEOUS) page displayed.
Cursor at OFFICE ID attribute.
4. Type and enter the appropriate **OFFICE ID** for field 1.
Response: System completes remainder of form.
Enter Insert, Change, Validate, or Print:
5. Type and enter: **c**
Response: Change Field:
6. For 5E14, type and enter **EADAS**
Response: Cursor at EADAS LINK attribute.
For 5E15 and later, type and enter **TRFM**
Response: Cursor at TRFM LINK attribute.
7. Type and enter: **y**
Response: Change Field:
8. Enter CARRIAGE RETURN
Response: Enter Update, Change, Validate, or Print:
9. Type and enter: **u**
Response: updating.....FORM UPDATED
OFFICE PARAMETERS (MISCELLANEOUS) page displayed.
Cursor at OFFICE ID attribute.
10. Type and enter: **<**
Response: 8.0 OFFICE MISCELLANEOUS AND ALARMS VIEWS page displayed.
11. Type and enter: **q** to quit Recent Change.
Response: RCV-196 COMPLETED
12. THIS IS A SAFE STOPPING POINT.

8.11.3 Connect Hardware for TDMS/EADAS Data Link

PROCEDURE

1. Verify that the internal jumpers of the RS422 to RS232 converter (ED5D764-30 G17A, Black Box # IC456A-R4) are set as illustrated in Figure 8.11.3-1

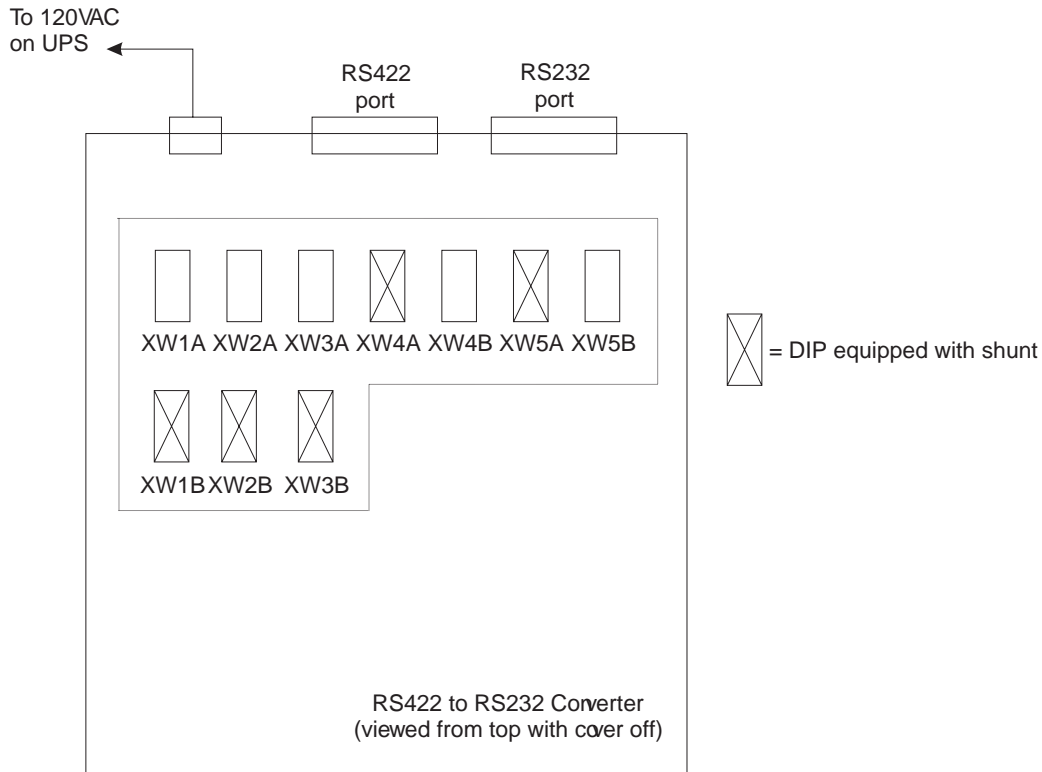

Figure 8.11.3-1 — DIP Shunt Settings for IC456A-R2

2. Connect the RS422 cable (ED5D764-30 G106, Black Box # EDN37J-00XX-MM; where XX is the cable length in feet) between port 3 on the High Speed Interface (HSI) and the RS422 port on the converter.
3. Connect the RS232 male to male cable (Black Box # ECM25C-0010-MM) from the RS232 port on the converter to the Data Communication Equipment (DCE), which may be a modem, DSU2, or router.
4. Plug the converter's AC power adapter into a UPS 120VAC outlet. Refer to Figures 8.11.3-2 , 8.11.3-3 and 8.11.3-4 for an illustration of the wiring configuration for the TDMS/EADAS or RMAS data link.

1. Trademark of Sun Microsystems, Inc.

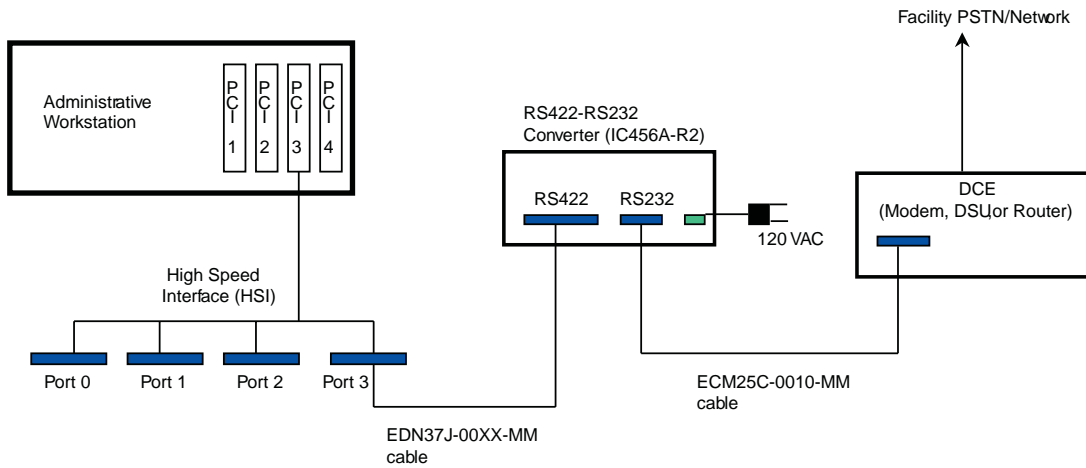

Figure 8.11.3-2 — Wiring Diagram for TDMS/EADAS or RMAS Data Link (*Netra*¹ t 1120)

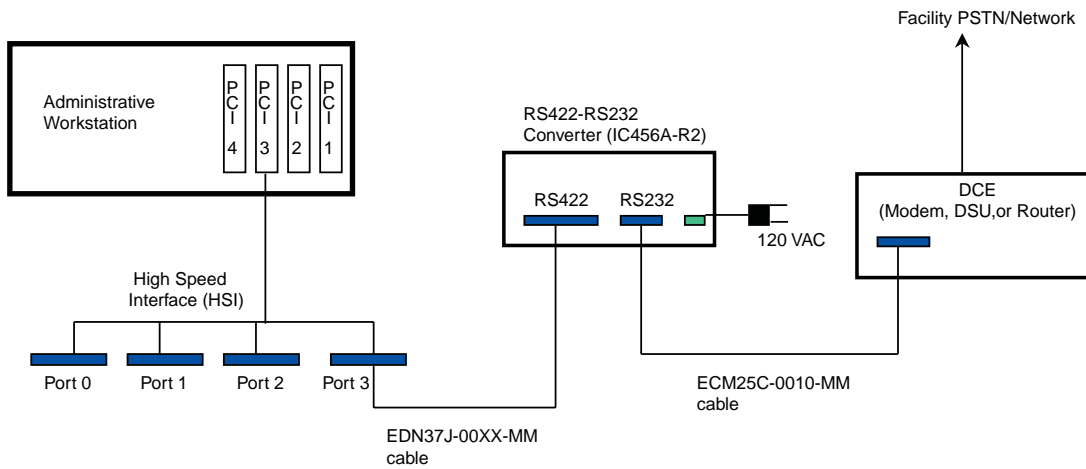

Figure 8.11.3-3 — Wiring Diagram for TDMS/EADAS or RMAS Data Link (*Netra* 20)

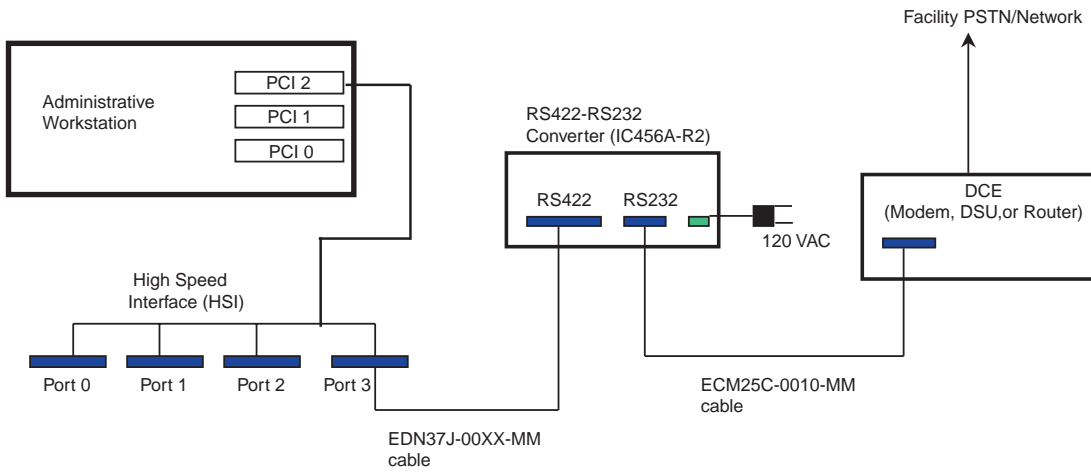

Figure 8.11.3-4 — Wiring Diagram for TDMS/EADAS or RMAS Data Link (Netra 240)

5. THIS IS A SAFE STOPPING POINT.

8.11.4 Define TDMS/EADAS Port on TDMS System

PROCEDURE

1. At this point, the DRM should be defined in the TDMS system. The DRM EADAS/TDMS data link from the DRM must be treated the same as the EADAS/TDMS datalink from a *5ESS*[®] switch.
2. THIS IS A SAFE STOPPING POINT.

8.11.5 Initialize TDMS/EADAS Processes

PROCEDURE

1. At the MCC, type and enter: **INIT:ULARP**

Response: INIT ULARP COMPLETED

2. At the MCC, type and enter the following commands:

INIT:AM,OKP,SPP,PID=27

INIT:AM,OKP,SPP,PID=19

INIT:AM,OKP,SPP,PID=80

Note: The following steps are optional but can be used to verify that the correct processes are running on the DRM to support the EADAS/TDMS data link. These steps can be used at anytime to verify the processes are active.

3. At the MCC, type and enter poke **194** to go to the SCREEN view. If a STLWS terminal is being used, enter the **120** poke to clear the screen, enter the **rcv:menu:sh** input command, and then skip to step **5**.
4. Type and enter: **u** to request access to the *UNIX*¹ Shell.
5. At the *UNIX* prompt, type and enter the following command:

ps -axkp | grep "as"

Response: The expected response should be (not necessarily in this order):

```
10 ? 78 /no5text/as/ECap
1 ? 98 /no5text/rcv/RCasrsys
10 ? 4784235 /no5text/as/ECr3
10 ? 1638508 /no5text/as/ECr4
10 ? 110 /no5text/as/AScotsys
10 ? 262258 /no5text/as/ECr6
10 ? 65651 /no5text/as/ECw6
10 ? 65652 /no5text/as/ECw3
10 ? 65653 /no5text/as/ECw4
10 ? 120 grep as
```

6. In order for the EADAS/TDMS data link to function properly, the ECap, ECr3, ECr4, ECr6, ECw3, ECw4, and ECw6 processes must be listed in the report indicating that those processes are running.
7. Type and enter: **exit** at the *UNIX* prompt.
8. If you are using the MCC, type and enter: **q** to exit out of the 194 SCREEN view.
9. THIS IS A SAFE STOPPING POINT.

1. Registered trademark in the United States and other countries, licensed exclusively through X/Open Company, Limited.

8.11.6 Restore TDMS/EADAS Data Link to Service

PROCEDURE

1. At the MCC, type and enter: **RST:SDLC=3** to restore SDLC3 to service.

Response: RST SDLC 3 COMPLETED

THIS IS A SAFE STOPPING POINT, proceed to Procedure 8.11.7

8.11.7 Verify Operation of TDMS/EADAS Data Link

PROCEDURE

1. After SDLC 3 is restored to service, verify that the link goes ACT on MCC page 113.

Note: It may take a minute or more for the link to go active.

2. Activate the collection of the TRFC30 data on the DRM by entering the following input command on the MCC/STLWS:

ALW:TRFC30,CLCT;

3. At the MCC enter the **OP:CLK** command to verify that the DRM clock minute is the same as the TDMS clock +/- 1 minute. If the DRM's clock is off by more than 1 minute, use the **SET:CLK** command to get it in sync with the TDMS clock.
4. Wait at least 30 minutes for the reports to get generated and then verify that TDMS received the data.

Note: The next set of steps can be optionally executed to monitor the X.25 protocol exchange between the DRM and the EADAS/TDMS OS.

Warning: *In order to monitor the X.25 protocol on the EADAS/TDMS data link, all of the other synchronous data links on the DRM must be temporarily removed from service. The following steps must not be performed if the DRM is being polled for AMA billing data, if the SCANS link is active, or if the TNMISCCS data link is required to be active.*

5. Remove all data links from service except the EADAS/TDMS data link by typing and entering the following input command on the MCC/STLWS for each data link except the EADAS/TDMS data link:

RMV:SDL=X; (where X= 0 for SCANS, 13 for AMA, etc)

6. Switch to the *Sun*¹ console by holding down the **Control Key** and depressing the **Enter Key** on the MCC's numeric keypad.
7. Enter CARRIAGE RETURN until the "console login:" prompt appears.
8. Login to the *Sun* console as root.
9. Type and enter the following command to activate the X.25 protocol analyzer built into the DRM:

/opt/SUNWconn/bin/x25trace -i /dev/lapb x25

Response: Parsed: x25
Time Protocol

10. At this point, any X.25 packets sent between the DRM and the EADAS/TDMS OS will be displayed on the *Sun* console.
11. To exit out of the X.25 protocol analyzer, enter **Control c** or hit the **Delete Key**.
12. To go back to the MCC hold down the **Control Key** and depress the **Enter Key** on the MCC's numeric keypad.
13. THIS IS A SAFE STOPPING POINT, proceed to Procedure 8.11.8

1. Registered trademark of Sun Microsystems, Inc.

8.11.8 Backup Office Dependent Data

PROCEDURE

1. At the MCC, type and enter: **BKUP:ODD**
Response: BKUP ODD COMPLETED
2. **STOP. YOU HAVE COMPLETED THIS PROCEDURE.**

8.12 Perform RMAS Data Link Growth

OVERVIEW

This procedure is used to grow the Remote Memory Administration System (RMAS) X.25 data link using ECD low-level forms. This OS uses bx.25 session layer over x.25. This procedure assumes the most common connection, which is using x.25 PVCs over a direct connection between the OS and the datalink (through a Modem, Router, IPDSU, etc).

This procedure assumes the link is to be grown on port 3 of the DRM's high speed interface (HSI).

Note: RMAS requires 5e15 and later to work in the DRM.

The following hardware must be on site:

- RS422 to RS232 converter (Black Box part # IC456A)
- RS422 cable (Black Box part # EDN37J-00XX-MM; where XX is the cable length in feet)
- RS232 cable (Black Box part # ECM25C-0010-MM)

This procedure takes approximately 2 hours to complete.

PROCEDURE

1. This process is a combination of procedures. Perform these procedures in the order in which they are presented.
 1. "Grow in RMAS Data Link in ECD," Procedure 8.12.1.
 2. "Connect Hardware for RMAS Data Link," Procedure 8.12.2.
 3. "Configure RMAS RC Access," Procedure 8.12.3.
 4. "Verify Operation of RMAS Data Link," Procedure 8.12.4.

8.12.1 Grow in RMAS Data Link in ECD

OVERVIEW

Warning: *ECD forms are case sensitive. Use capital letters where shown.*

PROCEDURE

1. **Grow in UCB for SDLC3**

At MCC, type and enter: **199** to access ECD RC/V.

Response: RCV ECD PARAMETER INFO page displayed with cursor at 1.
database_name

2. Type and enter: **incore**

Response: 2. review only

3. Type and enter: **n**

Response: 3. journaling

4. Type and enter: *****

Response: RCV INITIALIZATION IN PROGRESS message displayed. UNIX
RTR RCV (ODIN) - Data Entry page displayed. Cursor at Enter
Form Name:

5. Type and enter: **trbegin**

Response: Transaction Begin
1.tr_name: TRBEGIN

6. Enter CARRIAGE RETURN

Response: Enter Execute, Change. . .

7. Type and enter: **e**

8. Type and enter: **ucb**

Response: Enter Database Operation
I=Insert, R=Review, U=Update, D=Delete

9. Type and enter: **i**

10. Populate the fields of the UCB record according to the following UCB form:

```
ucb      (1/4)
Information About Each Physical Device      (Recent Change and Verify)

1.k_complex_name:_____  2.k_complex_number:____
3.k_unit_name:SDLC        4.k_unit_number:3
ucb_type 5.essential:Never 6.top:n      7.unique_unit:y
8.pseudo_node:n 9.restorable:y 10.removable:y
11.device_port:EMUDL 12.device_type:SDLC
13.internal_device:3 14.plant:y
15.critical:y 16.portswitch:n 17.posswitch:
```

```
                                ucb      (2/4)

minor_device_status      18.boot:n      19.rexinh:n      20.errlog:n

21.major_status:UNEQIP      22.equipage:

23.device_num:6            24.channel_num:11

25.hv:_____            26.mt:_____ 27.mv:_____

28.interrupt_num:        29.service_intrpt:___

30.pathname:pu/sdlc

31.location
  32.floor:1      33.aisle:a      34.plate:1      35.pack:1
```

```
                                ucb      (3/4)

      complex_name  complex_number  unit_name  unit_number
36.down  37)_____  38)_____  39)_____  40)_____

41.side  42)_____  43)_____  44)_____  45)_____

46.cntrl_0 47)_____  48)_____  49)___IOP_  50)___2_

51.cntrl_1 52)_____  53)_____  54)_____  55)_____

56.error_table:ioperr      57.option_name:

58.pcid:_3_  59.pcsdid:0      60.h_type:___

61.handler_id:np
```

```
                                ucb      (4/4)

62.packcode:u582      63.issue:2      64.version:

65.cvaddr:0xffff0      66.u_model:
```

11. After updating field 66 on the UCB form, enter CARRIAGE RETURN.
Response: Enter Insert, Change, Substitute, Validate, screen#, or Print:
12. Type and enter: **i**
Response: FORM INSERTED
13. Complete steps 14-30 if the SCC data link is not equipped on HSI port 2.
Otherwise, if the SCC data link is equipped on HSI port 2, skip to step 31.
14. **Warning: Only execute steps 14-30 if no data link is provisioned on HSI port 2.**
Type and enter: **^**
Response: Enter Database Operation
I=Insert, R=Review, U=Update, D=Delete
15. Type and enter: **u** and enter CARRIAGE RETURN twice.
Response: Cursor at K_UNIT_NAME

16. Type and enter: **SDLC**
Response: Cursor at K_UNIT_NUMBER
17. Type and enter: **1**
Response: Reading...
18. Type and enter: **c** to change a field.
Response: Cursor at Change field:
19. Type and enter: **44**
20. Type and enter: **SDLC**
Response: Cursor at Change field:
21. Type and enter: **45**
22. Type and enter: **3** and then enter a CARRIAGE RETURN
Response: Enter Database Operation
I=Insert, R=Review, U=Update, D=Delete
23. Type and enter: **u** to update the ucb record.
Response: FORM UPDATED
24. Type and enter: **<**
Response: Cursor at Enter Form Name:
25. Type and enter: **trend**
Response: 1. tr_name: TREND
2. dis_cf_checks:n
3. apply_tr:y
4. o_missing_links:n
26. Enter CARRIAGE RETURN 4 times.
Response: Enter Execute, Change. . .
27. Type and enter: **e**
Response: Executing
Enter Form Name:
28. Go to "Update UCB for SDLC3 to GROW State," Step **47**.
29. **Warning: Only execute steps 31-46 if a data link is provisioned on HSI port 2.**
Type and enter: **^**
Response: Enter Database Operation
I=Insert, R=Review, U=Update, D=Delete
30. Type and enter: **u** and enter CARRIAGE RETURN twice.
Response: Cursor at K_UNIT_NAME
31. Type and enter: **SDLC**
Response: Cursor at K_UNIT_NUMBER

32. Type and enter: **2**
Response: Reading...
33. Type and enter: **c** to change a field.
Response: Cursor at Change field:
34. Type and enter: **44**
35. Type and enter: **SDLC**
Response: Cursor at Change field:
36. Type and enter: **45**
37. Type and enter: **3** and then enter a CARRIAGE RETURN
Response: Enter Database Operation
I=Insert, R=Review, U=Update, D=Delete
38. Type and enter: **u** to update the ucb record.
Response: FORM UPDATED.
39. Type and enter: **<**
Response: Cursor at Enter Form Name:
40. Type and enter: **trend**
Response: 1. tr_name: TREND
2. dis_cf_checks:n
3. apply_tr:y
4. o_missing_links:n
41. Enter CARRIAGE RETURN 4 times.
Response: Enter Execute, Change. . .
42. Type and enter: **e**
Response: Executing
Enter Form Name:
43. **Update UCB for SDLC3 to GROW State**
Type and enter: **trbegin**
Response: Transaction Begin
1.tr_name: TRBEGIN
44. Enter CARRIAGE RETURN
Response: Enter Execute, Change. . .
45. Type and enter: **e**
46. Type and enter: **ucb**
Response: Enter Database Operation
I=Insert, R=Review, U=Update, D=Delete
47. Type and enter: **u** and enter CARRIAGE RETURN twice.
Response: Cursor at K_UNIT_NAME

48. Type and enter: **SDLC**
Response: Cursor at K_UNIT_NUMBER
49. Type and enter: **3**
Response: Reading...
50. Type and enter: **c** to change a field.
Response: Cursor at Change field:
51. Type and enter: **21** to change the MAJOR_STATUS field.
52. Type and enter: **GROW** and then enter CARRIAGE RETURN
Response: Enter Database Operation
I=Insert, R=Review, U=Update, D=Delete
53. Type and enter: **u** to update the ucb record.
Response: FORM UPDATED.
54. Type and enter: **<**
Response: Cursor at Enter Form Name:
55. Type and enter: **trend**
Response: 1. tr_name: TREND
2. dis_cf_checks:n
3. apply_tr:y
4. o_missing_links:n
56. Enter CARRIAGE RETURN 4 times.
Response: Enter Execute, Change. . .
57. Type and enter: **e**
Response: Executing
Enter Form Name:
58. **Insert UCB and NPHOPT for SDL9 and Update SDLC3 to Reference SDL9**
Type and enter: **trbegin**
Response: Transaction Begin
1.tr_name: TRBEGIN
59. Enter CARRIAGE RETURN
Response: Enter Execute, Change. . .
60. Type and enter: **e**
61. Type and enter: **ucb**
Response: Enter Database Operation
I=Insert, R=Review, U=Update, D=Delete
62. Type and enter: **i**
63. Populate the fields of the UCB record according to the following UCB form:

```
ucb (1/4)
Information About Each Physical Device (Recent Change and Verify)

1.k_complex_name:_____ 2.k_complex_number:___
3.k_unit_name:SDL 4.k_unit_number:9
ucb_type 5.essential:NEVER 6.top:n 7.unique_unit:y
8.pseudo_node:n 9.restorable:y 10.removable:y
11.device_port:EMUDL 12.device_type:SDL
13.internal_device:2 14.plant:y
15.critical:y 16.portswitch:n 17.posswitch:
```

```
ucb (2/4)

minor_device_status 18.boot:n 19.rexinh:n 20.errlog:n
21.major_status:UNEQIP 22.equipage:
23.device_num:6 24.channel_num:11
25.hv:_____ 26.mt:_____ 27.mv:___
28.interrupt_num: 29.service_intrpt:___
30.pathname:pu/sdl
31.location
32.floor:1 33.aisle:a 34.plate:1 35.pack:1
```

```
ucb (3/4)

36.down complex_name complex_number unit_name unit_number
37)_____ 38)___ 39)_____ 40)___
41.side 42)_____ 43)___ 44)_____ 45)___
46.cntrl_0 47)_____ 48)___ 49)_SDLC___ 50)_3__
51.cntrl_1 52)_____ 53)___ 54)_____ 55)___
56.error_table:ioperr 57.option_name:rmas
58.pcid:_3__ 59.pcsdid:2 60.h_type:___
61.handler_id:np
```

```
ucb (4/4)

62.packcode:___ 63.issue:___ 64.version:___
65.cvaddr:_____ 66.u_model:
```

64. After updating field 59 on the UCB form, enter CARRIAGE RETURN or > until the following response is observed.

Response: Enter Insert, Change, Substitute, Validate, screen#, or Print:

65. Type and enter: i

Response: FORM INSERTED

66. Type and enter: <

Response: Enter Form Name:

67. Type and enter: **nphopt**

Response: Enter Database Operation
I=Insert, R=Review, U=Update, D=Delete

68. Type and enter: i

69. Populate the fields of the NPHOPT record according to the following NPHOPT form.

Note: *There is a version of this form, which does not display the CAUTION at the top of the screen. As a result, the screen layout will differ slightly from the screens shown in this step. Make sure that the correct fields are being updated with the data shown in this step.

```
          nphopt          (1/7)
NPH Option Block Record          (Recent Change and Verify)
THESE ARE CRITICAL SYSTEM PARAMETERS!! CHANGE WITH EXTREME CAUTION. See Note *
1.option_name:rmas
2.speed: 2400      3.duplex:full      4.ds_type:703C00
5.carrier:c        6.line_access:private  7.mode_op:b
8.pdtime1:30      9.pdtime2:50      10.window:3
11.rexmit:7       12.dcedte:1
```

```
          nphopt          (2/7)
THESE ARE CRITICAL SYSTEM PARAMETERS!! CHANGE WITH EXTREME CAUTION. See Note *
13.nphldtel      sid      tlim      telno
1) _____
2) _____
3) _____
4) _____
17.security:n      18.link_id:0
19.feid_len:0      20.neid_len:0      21.password_len:0
```

nphopt (3/7)

THESE ARE CRITICAL SYSTEM PARAMETERS!! CHANGE WITH EXTREME CAUTION. See Note *

22.feid.fend

1) _____	4) _____	7) _____	10) _____	13) _____
2) _____	5) _____	8) _____	11) _____	14) _____
3) _____	6) _____	9) _____	12) _____	15) _____

33.neid.nend

1) _____	4) _____	7) _____	10) _____	13) _____
2) _____	5) _____	8) _____	11) _____	14) _____
3) _____	6) _____	9) _____	12) _____	15) _____

nphopt (4/7)

THESE ARE CRITICAL SYSTEM PARAMETERS!! CHANGE WITH EXTREME CAUTION. See Note *

44.pswrd.pwrd

1) _____	4) _____	7) _____	10) _____	13) _____
2) _____	5) _____	8) _____	11) _____	14) _____
3) _____	6) _____	9) _____	12) _____	15) _____

55.perm_state:allow 56.lana:_____ 57.estact_chnl:4

58.packetid:X25 59.fast_sel:y 60.fast_accept:y

61.connection:DCE 62.num_pvcs:4 63.losvc_lincome:_____

64.hisvc_lincome:_____ 65.losvc_2way:_____ 66.hisvc_2way:_____

nphopt (5/7)

THESE ARE CRITICAL SYSTEM PARAMETERS!! CHANGE WITH EXTREME CAUTION. See Note *

67.losvc_loutgo:_____ 68.hisvc_loutgo:_____ 69.t20_timer:180

70.t21_timer:200 71.t22_timer:180 72.t23_timer:180

73.t24_timer:60 74.t25_timer:150 75.t26_timer:18

76.r20_counter:1 77.r22_counter:1 78.r23_counter:1 79.nstd_ipsize:256

80.nstd_opsize:256 81.nstd_iwsiz:3 82.nstd_owsiz:3

nphopt (6/7)

THESE ARE CRITICAL SYSTEM PARAMETERS!! CHANGE WITH EXTREME CAUTION. See Note *

83.pvcopts

pnstdipsiz	pnstdopsiz	pnstdiwsiz	pnstdowsiz	user_name	spec_num
1)256	256	3	3	sessionlayer	1
2)256	256	3	3	sessionlayer	2
3)256	256	3	3	sessionlayer	3
4)256	256	3	3	sessionlayer	4
5)_____	_____	_____	_____	_____	_____
6)_____	_____	_____	_____	_____	_____
7)_____	_____	_____	_____	_____	_____
8)_____	_____	_____	_____	_____	_____

```

nphopt      (7/7)

THESE ARE CRITICAL SYSTEM PARAMETERS!!  CHANGE WITH EXTREME CAUTION. See Note *

83.pvcopts(cont)

pnstdipsiz  pnstdopsiz  pnstdiwsiz  pnstdowsiz  user_name      spec_num
9)  _____  _____  _____  _____  _____  _____
10) _____  _____  _____  _____  _____  _____
11) _____  _____  _____  _____  _____  _____

12) _____  _____  _____  _____  _____  _____
13) _____  _____  _____  _____  _____  _____
14) _____  _____  _____  _____  _____  _____
15) _____  _____  _____  _____  _____  _____
16) _____  _____  _____  _____  _____  _____

```

70. After updating field 83 on the NPHOPT form, enter CARRIAGE RETURN
Response: Enter Insert, Change, Substitute, Validate, screen#, or Print:
71. Type and enter: **i**
Response: FORM INSERTED
72. Type and enter: **<**
Response: Enter Form Name:
73. Type and enter: **ucb**
Response: Enter Database Operation
I=Insert, R=Review, U=Update, D=Delete
74. Type and enter: **u** and enter CARRIAGE RETURN twice.
Response: Cursor at K_UNIT_NAME
75. Type and enter: **SDLC**
Response: Cursor at K_UNIT_NUMBER
76. Type and enter: **3**
Response: Reading...
77. Type and enter: **c** to change a field.
Response: Cursor at Change field:
78. Type and enter: **39**
79. Type and enter: **SDL**
Response: Cursor at Change field:
80. Type and enter: **40**
81. Type and enter: **9** and then enter a CARRIAGE RETURN
Response: Enter Database Operation
I=Insert, R=Review, U=Update, D=Delete
82. Type and enter: **u** to update the ucb record.
Response: FORM UPDATED

83. Type and enter: <
Response: Cursor at Enter Form Name:
84. Type and enter: **trend**
Response: 1. tr_name: TREND
2. dis_cf_checks:n
3. apply_tr:y
4. o_missing_links:n
85. Enter CARRIAGE RETURN 4 times.
Response: Enter Execute, Change. . .
86. Type and enter: **e**
Response: Executing
Enter Form Name:
87. **Insert BXSLLOC and BXSLRMT Forms**
Type and enter: **trbegin**
Response: Transaction Begin
1.tr_name: TRBEGIN
88. Enter CARRIAGE RETURN
Response: Enter Execute, Change. . .
89. Type and enter: **e**
Response: FORM EXECUTED
90. Type and enter: **bxslloc**
Response: Enter Database Operation
I=Insert, R=Review, U=Update, D=Delete
91. Type and enter: **u**
92. 92. Update the form and verify the fields of the BXSLLOC record are the same as the following BXSLLOC form:

```
bxslloc (1/2)
Session Layer Local Users List (Recent Change and Verify)

1.loc_name:5ERMAS1

2.loc_addr loc1 loc2 loc3 loc4 loc5 loc6 loc7 loc8
          35 45 52 4d 41 53 31 _
          loc9 loc10 loc11 loc12 loc13 loc14 loc15 loc16
          _ _ _ _ _ _ _ _

19.origin_type:SL 20.sess_dialog:2SIM 21.prs_type:ASCII 22.resync:n
23.recov:n 24.scm_resp_time:260 25.spdu_resp_time:260
26.sresm_resp_time:120 27.srecm_wait_time:300 28.srecm_resp_time:300
```

```
bxslloc (2/2)
29.spdu_count:2 30.sresm_count:2 31.srecm_count:1 32.scm_count:1
33.procnm:/no5text/rcv/RCmaccnt1
34.maxproc:4
```

- 93. After updating field 34 on the BXSLLOC form, enter CARRIAGE RETURN
Response: Enter Insert, Change, Substitute, Validate, screen#, or Print:
- 94. Type and enter: **u**
Response: FORM UPDATED
- 95. Type and enter: **<**
Response: Enter Form Name:
- 96. Type and enter: **bxslrmt**
Response: Enter Database Operation
I=Insert, R=Review, U=Update, D=Delete
- 97. Type and enter: **i**
- 98. Populate the fields of the BXSLRMT record according to the following BSXLRMT form.

```
bxslrmt (1/1)
Session Layer Remote Users List (Recent Change and Verify)

1.rmt_name:RMAS

2.rmt_addr rmt1 rmt2 rmt3 rmt4 rmt5 rmt6 rmt7 rmt8
           52 4d 41 53
           rmt9 rmt10 rmt11 rmt12 rmt13 rmt14 rmt15 rmt16
           _ _ _ _ _ _ _ _

19.remote_dte addr_type address
1) PVC 1
2) PVC 2
3) PVC 3
4) PVC 4
```

- 99. After updating field 19 on the BXSLRMT form, enter CARRIAGE RETURN until the following response is observed.
Response: Enter Insert, Change, Substitute, Validate, screen#, or Print:
- 100. Type and enter: **i**
Response: FORM INSERTED
- 101. Type and enter: **<**
Response: Enter Form Name:

102. Type and enter: **trend**

Response: 1. tr_name: TREND
2. dis_cf_checks:n
3. apply_tr:y
4. o_missing_links:n

103. Enter CARRIAGE RETURN 4 times.

Response: Enter Execute, Change. . .

104. Type and enter: **e**

Response: Executing
Enter Form Name:

105. **Insert MDCT and LOGDEV Forms**

Type and enter: **trbegin**

Response: Transaction Begin
1.tr_name: TRBEGIN

106. Enter CARRIAGE RETURN

Response: Enter Execute, Change. . .

107. Type and enter: **e**

108. Type and enter: **mdct**

Response: Enter Database Operation
I=Insert, R=Review, U=Update, D=Delete

109. Type and enter: **i**

110. Populate the fields of the first MDCT record according to the following MDCT form.

Note: In the following form, Field 3 (mdct_type) is set to the lower case letter "l".

Logical To Physical Device		mdct	(1/3)	
		Transaction	(Recent Change and Verify)	
1.mdct_name:RMAS		2.logical_device:io		
3.mdct_type:l		4.mdct_id_char:0		
5.active_devices				
6.complex_name	7.complex_number	8.unit_name	9.unit_number	
1) _____	_____	SDL	9	
2) _____	_____	_____	_____	
3) _____	_____	_____	_____	
4) _____	_____	_____	_____	

mdct (2/3)			
10.backup_devices			
11.complex_name	12.complex_number	13.unit_name	14.unit_number
1) _____	_____	_____	_____
2) _____	_____	_____	_____
3) _____	_____	_____	_____
4) _____	_____	_____	_____
15.spare_devices			
16.complex_name	17.complex_number	18.unit_name	19.unit_number
1) _____	_____	_____	_____
2) _____	_____	_____	_____
3) _____	_____	_____	_____
4) _____	_____	_____	_____

mdct (3/3)			
20.oos_devices			
21.complex_name	22.complex_number	23.unit_name	24.unit_number
1) _____	_____	_____	_____
2) _____	_____	_____	_____
3) _____	_____	_____	_____
4) _____	_____	_____	_____
25.gettyid:_____			

111. After updating field 25 on the MDCT form, enter CARRIAGE RETURN until the following response is observed.

Response: Enter Insert, Change, Substitute, Validate, screen#, or Print:

112. Type and enter: **i**

Response: FORM INSERTED

113. Type and enter: **<**

Response: Enter Form Name:

114. Type and enter: **logdev**

Response: Enter Database Operation
I=Insert, R=Review, U=Update, D=Delete

115. Type and enter: **i**

116. Populate the fields of the LOGDEV record according to the following LOGDEV form.

logdev (1/1) (Recent Change and Verify)	
Logical Device Information	
1.logical_name:/dev/rmas1	2.partition:0x1
3.mdct_name:RMAS	4.channel_id:___
5.dcn:23	6.driver_type:c
7.gettyid:_____	8.usr:rw-
9.grp:rw-	10.other:---

117. After updating field 10 on the LOGDEV form, enter CARRIAGE RETURN until the following response is observed.

Response: Enter Insert, Change, Substitute, Validate, screen#, or Print:

118. Type and enter: **i**

Response: **FORM INSERTED**

119. Populate the fields of the second LOGDEV record according to the following LOGDEV form.

logdev (1/1)	
Logical Device Information (Recent Change and Verify)	
1.logical_name:/dev/rmas2	2.partition:0x2
3.mdct_name:RMAS	4.channel_id:___
5.dcn:23	6.driver_type:c
7.gettyid:_____	8.usr:rw-
9.grp:rw-	10.other:---

120. After updating field 19 on the LOGDEV form, enter CARRIAGE RETURN until the following response is observed.

Response: Enter Insert, Change, Substitute, Validate, screen#, or Print:

121. Type and enter: **i**

Response: **FORM INSERTED**

122. Populate the fields of the third LOGDEV record according to the following LOGDEV form.

logdev (1/1)	
Logical Device Information (Recent Change and Verify)	
1.logical_name:/dev/rmas3	2.partition:0x3
3.mdct_name:RMAS	4.channel_id:___
5.dcn:23	6.driver_type:c
7.gettyid:_____	8.usr:rw-
9.grp:rw-	10.other:---

123. After updating field 10 on the LOGDEV form, enter CARRIAGE RETURN until the following response is observed.

Response: Enter Insert, Change, Substitute, Validate, screen#, or Print:

124. Type and enter: **i**

Response: **FORM INSERTED**

125. Populate the fields of the fourth LOGDEV record according to the following LOGDEV form.

```
logdev (1/1)
Logical Device Information (Recent Change and Verify)
  1.logical_name:/dev/rmas4      2.partition:0x4
  3.mdct_name:RMAS              4.channel_id:___
  5.dcn:23                      6.driver_type:c
  7.gettyid:_____             8.usr:rw-
  9.grp:rw-                     10.other:---
```

126. After updating field 130 on the LOGDEV form, enter CARRIAGE RETURN until the following response is observed.

Response: Enter Insert, Change, Substitute, Validate, screen#, or Print:

127. Type and enter: **i**

Response: FORM INSERTED

128. Type and enter: **^**

Response: Enter Database Operation
I=Insert, R=Review, U=Update, D=Delete

129. Type and enter: **u**:

130. Change any of the fields in this LOGDEV record to match the following LOGDEV form.

```
logdev (1/1)
Logical Device Information (Recent Change and Verify)
  1.logical_name:/dev/bx25session 2.partition:0x5
  3.mdct_name:bx25sess           4.channel_id:___
  5.dcn:23                      6.driver_type:c
  7.gettyid:_____             8.usr:rwx
  9.grp:r-x                     10.other:---
```

131. Type and enter: **u**

Response: FORM UPDATED

132. Type and enter: **<**

Response: Cursor at Enter Form Name:

133. Type and enter: **trend**

Response: 1. tr_name: TREND
2. dis_cf_checks:n
3. apply_tr:y
4. o_missing_links:n

134. Enter CARRIAGE RETURN 4 times.

Response: Enter Execute, Change. . .

135. Type and enter: **e**
Response: Executing
Enter Form Name:
136. **Update UCB for SDL9 to GROW**
Type and enter: **trbegin**
Response: Transaction Begin
1.tr_name: TRBEGIN
137. Enter CARRIAGE RETURN
Response: Enter Execute, Change. . .
138. Type and enter: **e**
139. Type and enter: **ucb**
Response: Enter Database Operation
I=Insert, R=Review, U=Update, D=Delete
140. Type and enter: **u** and enter CARRIAGE RETURN twice.
Response: Cursor at K_UNIT_NAME
141. Type and enter: **SDL**
Response: Cursor at K_UNIT_NUMBER
142. Type and enter: **9**
Response: Reading...
143. Type and enter: **c** to change a field.
Response: Cursor at Change field:
144. Type and enter: **21** to change the MAJOR_STATUS field.
145. Type and enter: **GROW** and enter CARRIAGE RETURN
Response: Enter Database Operation
I=Insert, R=Review, U=Update, D=Delete
146. Type and enter: **u** to update the ucb record.
Response: FORM UPDATED
147. Type and enter: **<**
Response: Cursor at Enter Form Name:
148. Type and enter: **trend**
Response: 1. tr_name: TREND
2. dis_cf_checks:n
3. apply_tr:y
4. o_missing_links:n
149. Enter CARRIAGE RETURN 4 times.
Response: Enter Execute, Change. . .

150. Type and enter: **e**
Response: Executing
Enter Form Name:
151. **Update UCB for SDLC3 and SDL9 to OOS State**
Type and enter: **trbegin**
Response: Transaction Begin
1.tr_name: TRBEGIN
152. Enter CARRIAGE RETURN
Response: Enter Execute, Change. . .
153. Type and enter: **e**
154. Type and enter: **ucb**
Response: Enter Database Operation
I=Insert, R=Review, U=Update, D=Delete
155. Type and enter: **u** and enter CARRIAGE RETURN twice.
Response: Cursor at K_UNIT_NAME
156. Type and enter: **SDLC**
Response: Cursor at K_UNIT_NUMBER
157. Type and enter: **3**
Response: Reading...
158. Type and enter: **c** to change a field.
Response: Cursor at Change field:
159. Type and enter: **21** to change the MAJOR_STATUS field.
160. Type and enter: **OOS** and enter CARRIAGE RETURN
Response: Enter Database Operation
I=Insert, R=Review, U=Update, D=Delete
161. Type and enter: **u** to update the ucb record.
Response: FORM UPDATED.
162. Type and enter: **SDL** and enter CARRIAGE RETURN twice.
Response: Cursor at K_UNIT_NUMBER
163. Type and enter: **9**
Response: Reading...
164. Type and enter: **2** to view screen # 2.
165. Type and enter: **c** to change a field.
Response: Cursor at Change field:
166. Type and enter: **21** to change the MAJOR_STATUS field.

167. Type and enter: **OOS** and enter CARRIAGE RETURN
Response: Enter Database Operation
I=Insert, R=Review, U=Update, D=Delete
168. Type and enter: **u** to update the ucb record.
Response: FORM UPDATED.
169. Type and enter: **<**
Response: Cursor at Enter Form Name:
170. Type and enter: **trend**
Response: 1. tr_name: TREND
2. dis_cf_checks:n
3. apply_tr:y
4. o_missing_links:n
171. Enter CARRIAGE RETURN 4 times.
Response: Enter Execute, Change. . .
172. Type and enter: **e**
Response: Executing
Enter Form Name:
173. **Save ECD Changes to Disk**
Type and enter: **activate** to save the ECD changes to disk.
Response: 1.copy_inc_to_disk:YES
174. Enter CARRIAGE RETURN
Response: Enter Execute, Change. . .
175. Type and enter: **e**
Response: Executing..
176. Type and enter: **<** to exit ECD RC/V.
177. Go to the EAI page on the MCC terminal and execute the **58 Boot+UX** (UNIX) command.
178. Go to page 113 and verify RMAS link shows up.

8.12.2 Connect Hardware for RMAS Data Link

PROCEDURE

1. Verify that the internal jumpers of the RS422 to RS232 converter (ED5D764-30 G17A, Black Box # IC456A-R4) are set as illustrated in Figure 8.11.3-1.
2. Connect the RS422 cable (ED5D764-30 G106, Black Box # EDN37J-00XX-MM; where XX is the cable length in feet) between port 3 on the High Speed Interface (HSI) and the RS422 port on the converter.
3. Connect the RS232 male to male cable (Black Box # ECM25C-0010-MM) from the RS232 port on the converter to the Data Communication Equipment (DCE), which may be a modem, DSU2, or router.
4. Plug the converter's AC power adapter into a UPS 120VAC outlet. Refer to Figures 8.11.3-2 , 8.11.3-3 and 8.11.3-4 for an illustration of the wiring configuration for the TDMS/EADAS or RMAS data link.
5. THIS IS A SAFE STOPPING POINT.

8.12.3 Configure RMAS RC Access

PROCEDURE

1. At the MCC, type and enter: **RST:SDLC=3** to restore SDLC3 to service
Response: RST SDLC 3 COMPLETED
2. At the MCC, type and enter **SET:RCACCESS,TTY="RCOS4",ACCESS=a;**
Where: a = Obtained from the *235-600-700Input Messages Manual*(ie a=1-29,33)
3. Type and enter: **OP:RCACCESS,TTYP="RCOS4";**
Response: Access code will be returned in hexadecimal.
4. Repeat Steps 2 and 3 for TTYp changes "RCOS5", "RCOS6", and "RCOS7".
5. Type and enter: **BKUP:ODD;**
6. THIS IS A SAFE STOPPING POINT.

8.12.4 Verify Operation of RMAS Data Link

PROCEDURE

1. After SDLC 3 is restored to service, verify that the link goes ACT on MCC page 113.

Note: *This section is OPTIONAL:* The next set of steps can be optionally executed to monitor the X.25 protocol exchange between the DRM and the RMAS OS.

2. Switch to the *Sun*¹ console by holding down the **Control Key** and depressing the **Enter Key** on the MCC's numeric keypad.
3. Enter CARRIAGE RETURN until the "console login:" prompt appears.
4. Type and enter the following command to activate the X.25 protocol analyzer built into the DRM:

```
/opt/SUNWconn/bin/x25trace -i /dev/lapb -l 3 x25
```

```
Response:  Parsed: x25  
          Time Protocol
```

5. At this point, any X.25 packets sent between the DRM and the RMAS OS will be displayed on the *Sun* console.
6. To exit out of the X.25 protocol analyzer, enter **Control c** or hit the **Delete Key**.
7. Type **exit** to exit from root login in the *Sun* console.
8. To go back to the MCC hold down the **Control Key** and depress the **Enter Key** on the MCC's numeric keypad.
9. STOP. YOU HAVE COMPLETED THIS PROCEDURE

1. Registered trademark of Sun Microsystems, Inc.

8.13 Perform Traffic Printer Growth

PROCEDURE

1. Enter *UNIX*¹ RTR Recent Change and Verify.
 - (a) Is MCC or STLWS terminal to be used?
For MCC, proceed to Step **b**.
For STLWS proceed to Step **i**.
 - (b) At MCC, ensure terminal is in command mode.
 - (c) At MCC, do Steps **d** through **h**.
 - (d) Type and enter: **199**
Response: RCV PARAMETER INFO page displayed with cursor at 1.
database_name
 - (e) Type and enter: **incore**
Response: 2. review only
 - (f) Type and enter: **n**
Response: 3. journaling
 - (g) Type and enter: *****
Response: RCV INITIALIZATION IN PROGRESS message displayed.
UNIX RTR RCV (ODIN) - Data Entry page displayed.
 - (h) You have completed Enter *UNIX* RTR Recent Change and Verify, proceed to Step **2**.
 - (i) At STLWS terminal, type and enter: **RCV:MENU:DATA,RCVECD**
Response: RCV ECD PARAMETER INFO page displayed with cursor at 1.
database_name
 - (j) Type and enter: **incore**
Response: 2. review only
 - (k) Type and enter: **n**
Response: 3. journaling
 - (l) Type and enter: *****
Response: RCV INITIALIZATION IN PROGRESS message displayed.
UNIX RTR RCV (ODIN) - Data Entry page displayed. Cursor
at Enter Form Name:
2. Enter high-level forms.
 - (a) Type and enter: **toggle**
Response: Will take you to the high-level forms.
3. Insert TTY data.

1. Registered trademark in the United States and other countries, licensed exclusively through X/Open Company, Limited.

- (a) Type and enter: **ttyadd**

Response: ttyadd form displayed. Cursor at 1.tty_name:

Note: An ! may be entered any time prompted to abort the form and return to the state when the form was started.

- (b) Type and enter the following data:

1. tty_name^a: enter TTY7
2. baud_rate: enter (as specified or CARRIAGE RETURN)
3. login_term: enter (as specified or CARRIAGE RETURN)
4. auth_chk: enter (as specified or CARRIAGE RETURN)
5. term_type: enter (as specified or CARRIAGE RETURN)
6. line_mode: enter (as specified or CARRIAGE RETURN)
7. port: enter 2 or 3 for TTYC port (see Table 8.3-1 and 8.3-2)
8. ttyc_number: enter TTYC number base on SAI port (see Table 8.3-1 and 8.3-2)
9. plu_unit_name: enter CARRIAGE RETURN
10. plu_unit_number: enter CARRIAGE RETURN

Note(s):

- a. tty_name must be entered in all capital letters.

Note: Fields not specified receive the default value by entering CARRIAGE RETURN.

Note: When growing a TTY terminal a defensive check failure message REPT CONFIG FAULT Assert = 412 may be received. This failure message may be ignored.

4. Install the traffic printer to the SAI port corresponding to the TTYC port and TTYC number chosen in Tables 8.3-1 and 8.3-2 (see Figures 8.13-1 , 8.13-2 and 8.13-3).
 - (a) Enter CARRIAGE RETURN

2. Trademark of Sun Microsystems, Inc.

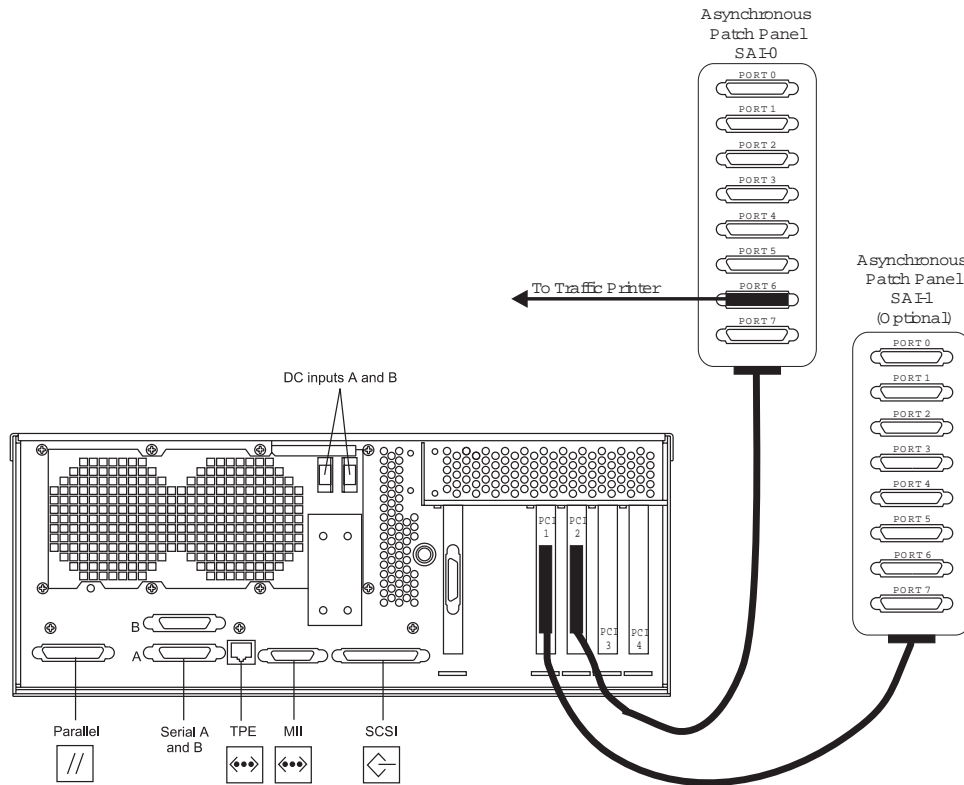

Figure 8.13-1 — Traffic Printer Installation (*Netra² t 1120*)

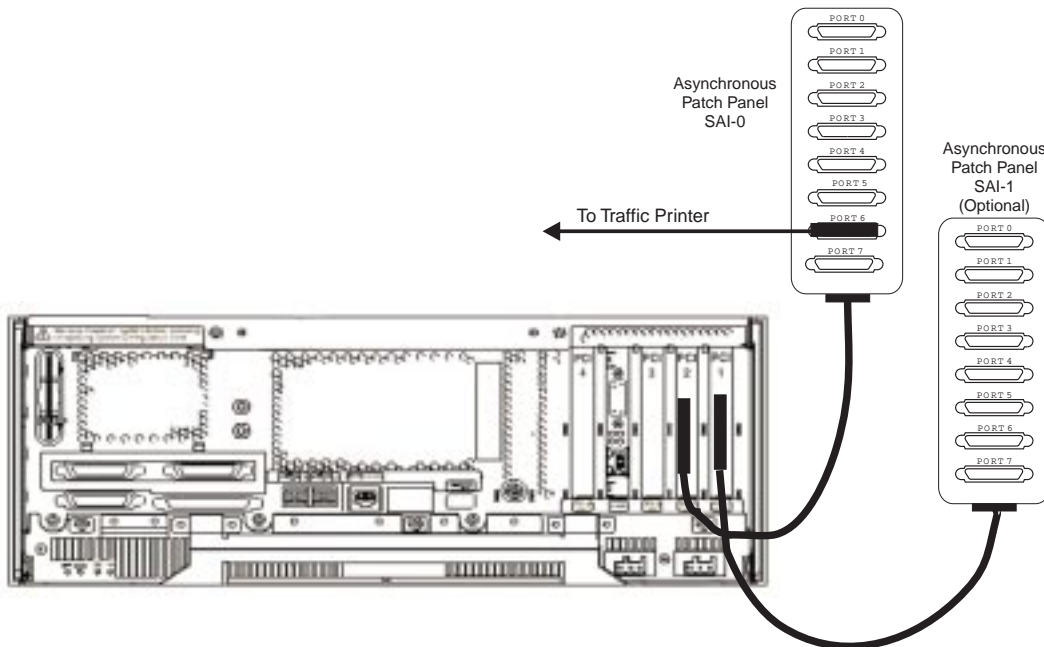

Figure 8.13-2 — Traffic Printer Installation (*Netra 20*)

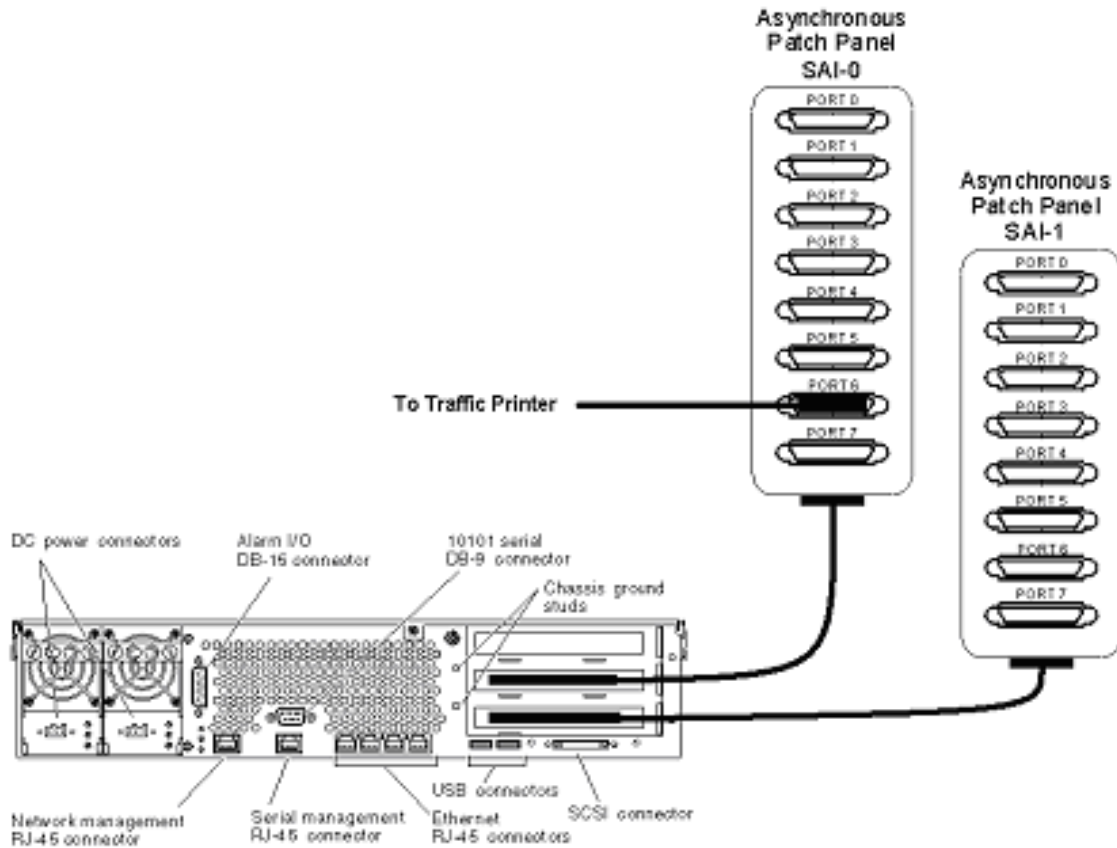

Figure 8.13-3 — Traffic Printer Installation (Netra 240)

5. Restore TTY x to service.
 - (a) At MCC, type and enter the appropriate message:
RST:TTY=x
Where: x = appropriate TTY number.
Response: RST TTY x COMPLETED
 - (b) Enter CARRIAGE RETURN
Response: FORM INSERTED
 - (c) Type and enter: <
Response: Exit the ttyadd form.
 - (d) Type and enter: <
Response: Exit this recent change session.
6. Backup Incore ECD to disk.
 - (a) At MCC, do Steps **b** through **i**.

- (b) Type and enter: **199**
Response: RCV PARAMETER INFO page displayed with cursor at 1.
database_name
 - (c) Type and enter: **incore**
Response: 2. review only
 - (d) Type and enter: **n**
Response: 3. journaling
 - (e) Type and enter: *****
Response: UNIX RTR (ODIN) - Data Entry page displayed.
 - (f) Type and enter: **activate**
Response: activate form displayed with cursor at 1. copy_inc_to_disk:
 - (g) Type and enter: **yes**
Response: ODIN will request the action desired.
 - (h) Type and enter: **e**
Response: ODIN returns to the UNIX RTR (ODIN) - Data Entry page.
 - (i) Type and enter: **<**
Response: RCV MENU RCV ECD COMPLETED
7. Backup Office Dependent Data.
- Note:** Prior to the response there will be completed responses for the switching module and the AM.
- a. At MCC, type and enter: **BKUP:ODD**
Response: **BKUP ODD COMPLETED**
It is recommended that primary disk be backed up and that a shelf copy of the disks be made.
8. **STOP. YOU HAVE COMPLETED THIS PROCEDURE.**

8.14 Perform Office Record Printer Growth

PROCEDURE

1. Enter *UNIX*¹ RTR Recent Change and Verify.
 - (a) Is MCC or STLWS terminal to be used?
For MCC, proceed to Step **b**.
For STLWS proceed to Step **i**.
 - (b) At MCC, ensure terminal is in command mode.
 - (c) At MCC, do Steps **d** through **h**.
 - (d) Type and enter: **199**
Response: RCV PARAMETER INFO page displayed with cursor at 1.
database_name
 - (e) Type and enter: **incore**
Response: 2. review only
 - (f) Type and enter: **n**
Response: 3. journaling
 - (g) Type and enter: *****
Response: RCV INITIALIZATION IN PROGRESS message displayed.
UNIX RTR RCV (ODIN) - Data Entry page displayed.
 - (h) You have completed Enter *UNIX* RTR Recent Change and Verify, proceed to Step **2**.
 - (i) At STLWS terminal, type and enter: **RCV:MENU:DATA,RCVECD**
Response: RCV ECD PARAMETER INFO page displayed with cursor at 1.
database_name
 - (j) Type and enter: **incore**
Response: 2. review only
 - (k) Type and enter: **n**
Response: 3. journaling
 - (l) Type and enter: *****
Response: RCV INITIALIZATION IN PROGRESS message displayed.
UNIX RTR RCV (ODIN) - Data Entry page displayed. Cursor
at Enter Form Name:
2. Enter high-level forms.
 - (a) Type and enter: **toggle**
Response: Will take you to the high-level forms.
3. Insert TTY data.

1. Registered trademark in the United States and other countries, licensed exclusively through X/Open Company, Limited.

- (a) Type and enter: **ttyadd**

Response: ttyadd form displayed. Cursor at 1.tty_name:

Note: An ! may be entered any time prompted to abort the form and return to the state when the form was started.

Note: Fields not specified receive the default value by entering CARRIAGE RETURN.

- (b) Type and enter the following data:

1. tty_name^a: enter TTY43
2. baud_rate: enter CARRIAGE RETURN^b
3. login_term: enter CARRIAGE RETURN
4. auth_chk: enter CARRIAGE RETURN
5. term_type: enter CARRIAGE RETURN
6. line_mode: enter CARRIAGE RETURN
7. port: enter 2 or 3 for TTYC port (see Tables 8.3-1 and 8.3-2)
8. ttyc_number: enter TTYC number base on SAI port (see Tables 8.3-1 and 8.3-2)
9. plu_unit_name: enter CARRIAGE RETURN
10. plu_unit_number enter CARRIAGE RETURN

Note(s):

- a. tty_name must be entered in all capital letters.
- b. The default baud rate is 1200. If a different baud rate is desired, "Update the Office Record Printer Baud Rate," Subprocedure 8.14.1, can be performed **after** Step 4 of this procedure is complete.

- (c) Type and enter: **i**

Note: When growing a TTY terminal a defensive check failure message REPT CONFIG FAULT Assert = 412 may be received. This failure message may be ignored.

4. Install the office record printer to the SAI port corresponding to the TTYC port and TTYC number chosen in Tables 8.3-1 and 8.3-2 (see Figures 8.14-1, 8.14-2 and 8.14-3).

- (a) Enter CARRIAGE RETURN

2. Trademark of Sun Microsystems, Inc.

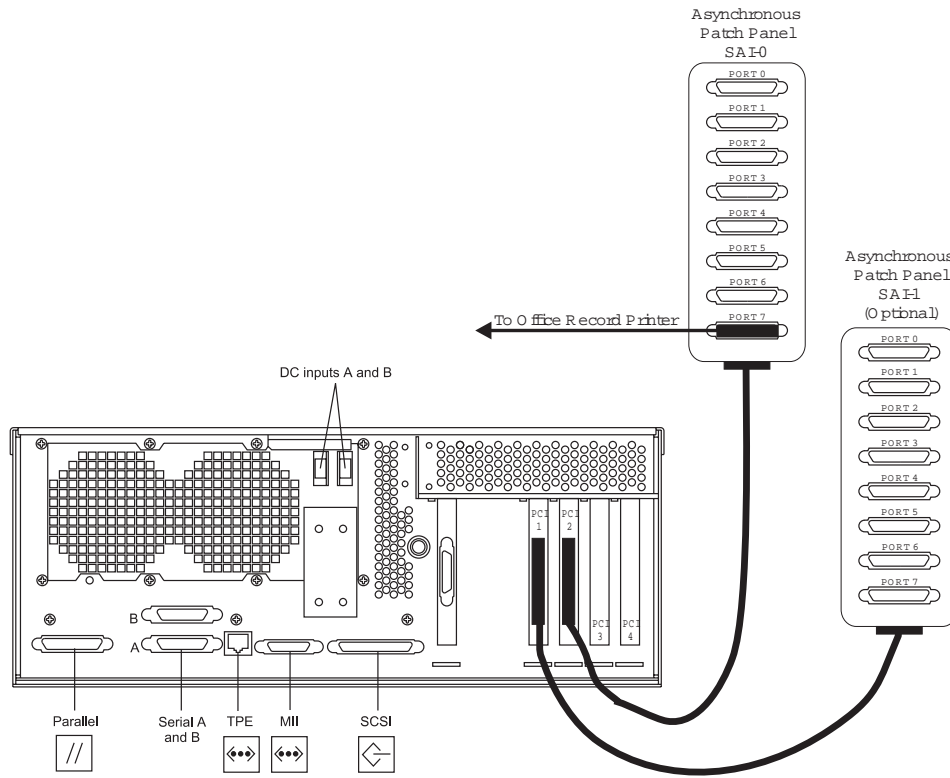

Figure 8.14-1 — Office Record Printer Installation (*Netra*² t 1120)

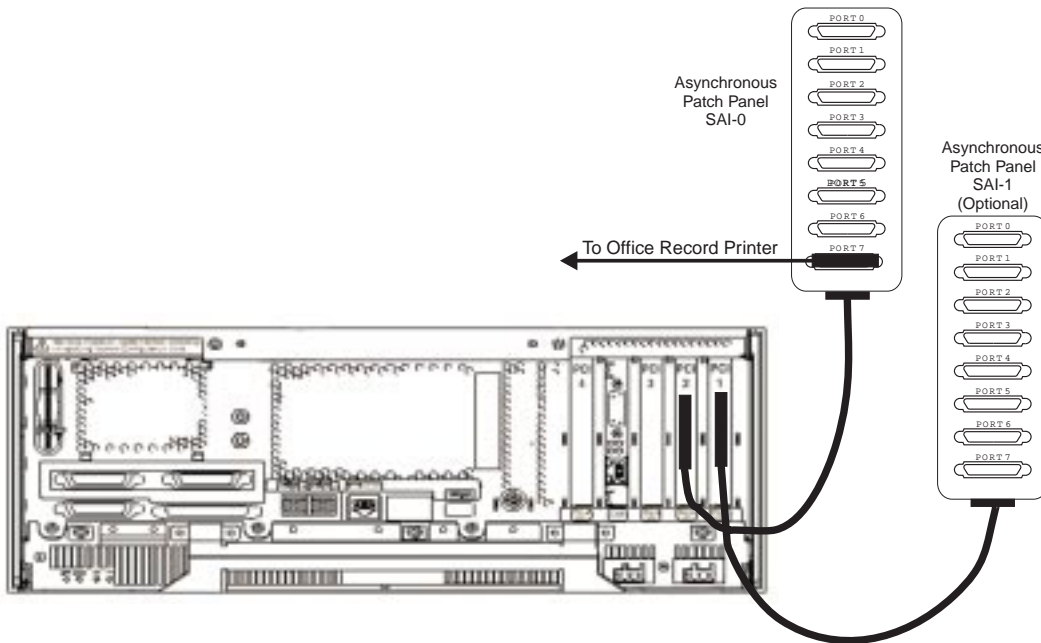

Figure 8.14-2 — Office Record Printer Installation (*Netra* 20)

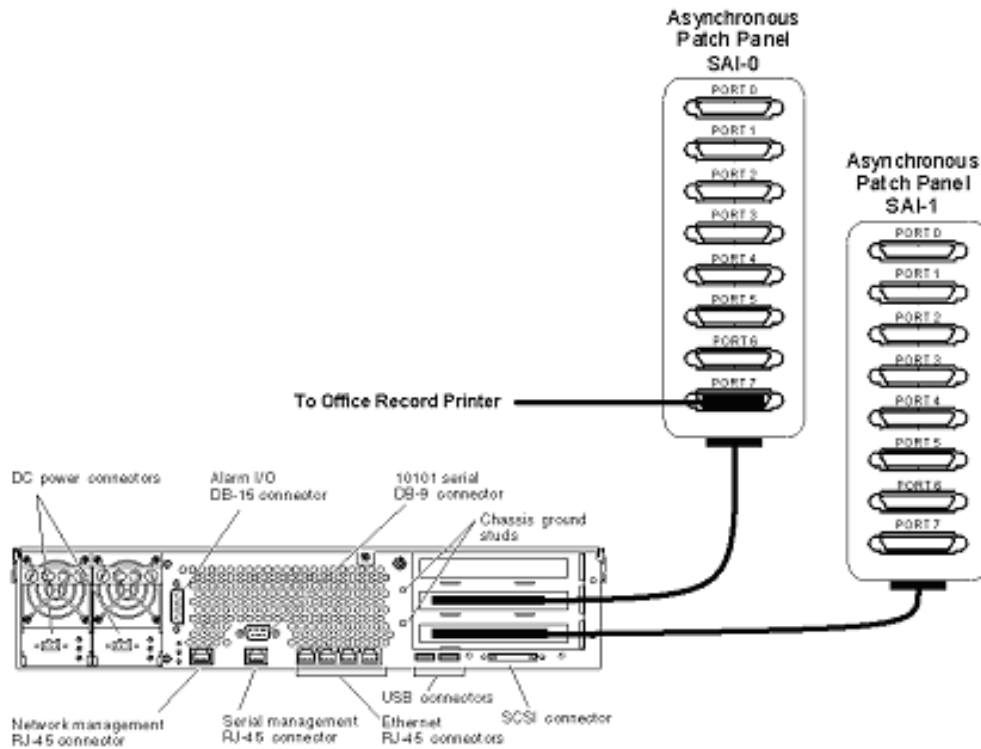

Figure 8.14-3 — Office Record Printer Installation (Netra 240)

5. Restore TTY x to service.

Note: If a baud rate other than 1200 is desired, "Update the Office Record Printer Baud Rate," Subprocedure 8.14.1, should be performed before restoring the TTY to service.

- (a) At MCC, type and enter the appropriate message:

RST:TTY=x

Where: x = appropriate TTY number.

Response: RST TTY x COMPLETED

- (b) Enter CARRIAGE RETURN

Response: FORM INSERTED

- (c) Type and enter: <

Response: Exit the ttyadd form.

- (d) Type and enter: <

Response: Exit the recent change session.

6. Backup Incore ECD to disk.

- (a) At MCC, do Steps **b** through **i**.

- (b) Type and enter: **199**
Response: RCV PARAMETER INFO page displayed with cursor at 1.
database_name
 - (c) Type and enter: **incore**
Response: 2. review only
 - (d) Type and enter: **n**
Response: 3. journaling
 - (e) Type and enter: *****
Response: UNIX RTR (ODIN) - Data Entry page displayed.
 - (f) Type and enter: **activate**
Response: activate form displayed with cursor at 1. copy_inc_to_disk:
 - (g) Type and enter: **yes**
Response: ODIN will request the action desired.
 - (h) Type and enter: **e**
Response: ODIN returns to the UNIX RTR (ODIN) - Data Entry page.
 - (i) Type and enter: **<**
Response: RCV MENU RCV ECD COMPLETED
7. Backup Office Dependent Data.
- Note:** Prior to the response there will be completed responses for the switching module and the AM.
- a. At MCC, type and enter: **BKUP:ODD**
Response: **BKUP ODD COMPLETED**
- It is recommended that primary disk be backed up and that a shelf copy of the disks be made.
8. **STOP. YOU HAVE COMPLETED THIS PROCEDURE.**

8.14.1 Update the Office Record Printer Baud Rate

OVERVIEW

When performing an office record printer growth, the office record printer baud rate defaults to 1200. This subprocedure allows maintenance personnel to update the baud rate to a range between 1200 and 9600.

PROCEDURE

1. Enter *UNIX*¹ RTR Recent Change and Verify.
 - (a) Is MCC or STLWS terminal to be used?
For MCC, proceed to Step **b**.
For STLWS proceed to Step **i**.
 - (b) At MCC, ensure terminal is in command mode.
 - (c) At MCC, do Steps **d** through **h**.
 - (d) Type and enter: **199**
Response: RCV PARAMETER INFO page displayed with cursor at 1.
database_name
 - (e) Type and enter: **incore**
Response: 2. review only
 - (f) Type and enter: **n**
Response: 3. journaling
 - (g) Type and enter: *****
Response: RCV INITIALIZATION IN PROGRESS message displayed.
UNIX RTR RCV (ODIN) - Data Entry page displayed.
 - (h) You have completed Enter *UNIX* RTR Recent Change and Verify, proceed to Step **2**.
 - (i) At STLWS terminal, type and enter: **RCV:MENU:DATA,RCVECD**
Response: RCV ECD PARAMETER INFO page displayed with cursor at 1.
database_name
 - (j) Type and enter: **incore**
Response: 2. review only
 - (k) Type and enter: **n**
Response: 3. journaling
 - (l) Type and enter: *****
Response: RCV INITIALIZATION IN PROGRESS message displayed.
UNIX RTR RCV (ODIN) - Data Entry page displayed. Cursor
at Enter Form Name:

1. Registered trademark in the United States and other countries, licensed exclusively through X/Open Company, Limited.

2. Type and enter: **trbegin**
Response: Transaction Begin
1.tr_name: TRBEGIN
3. Enter CARRIAGE RETURN
Response: Enter Execute, Change. . .
4. Type and enter: **e**
5. Type and enter: **ttopt**
Response: Enter Database Operation
I=Insert, R=Review, U=Update, D=Delete
6. Type and enter: **u**
7. Type and enter: **ofr0tt**
8. Type and enter: **c**
9. Type and enter: **16**
10. Type and enter the desired baud rate (**1200, 2400, 4800, or 9600**).
11. Enter CARRIAGE RETURN
12. Type and enter: **u**
Response: Form Updated
13. Type and enter: **<**
14. Type and enter: **trend**
Response: 1. tr_name:TREND
2. dis_cf_checks:n
3. apply_tr:y
4. o_missing_links:n
15. Enter the CARRIAGE RETURN 4 times.
Response: Enter Execute, Change...
16. Type and enter: **e**
17. Type and enter: **activate**
Response: 1. copy_inc_to_disk:YES
18. Enter CARRIAGE RETURN
Response: Enter Execute, Change...
19. Type and enter: **e**
Response: Executing
20. Type and enter: **<**
21. At the MCC or STLWS, type and enter: **RST:TTY=43**
22. **STOP. YOU HAVE COMPLETED THIS PROCEDURE.**

8.15 Perform Virtual TTY Controller Degrowth

OVERVIEW

This procedure is used to degrow a virtual TTY controller. For more information, see 235-600-XXX, **5ESS**[®] *Switch ECD/SG Database Manual*.

PROCEDURE

1. Enter *UNIX*¹ RTR Recent Change and Verify.
 - (a) Is MCC or STLWS terminal to be used?
For MCC, proceed to Step **b**.
For STLWS proceed to Step **i**.
 - (b) At MCC, ensure terminal is in command mode.
 - (c) At MCC, do Steps **d** through **h**.
 - (d) Type and enter: **199**
Response: RCV PARAMETER INFO page displayed with cursor at 1.
database_name
 - (e) Type and enter: **incore**
Response: 2. review only
 - (f) Type and enter: **n**
Response: 3. journaling
 - (g) Type and enter: *****
Response: RCV INITIALIZATION IN PROGRESS message displayed.
UNIX RTR RCV (ODIN) - Data Entry page displayed.
 - (h) You have completed Enter *UNIX* RTR Recent Change and Verify, proceed to Step **2**.
 - (i) At STLWS terminal, type and enter: **RCV:MENU:DATA,RCVECD**
Response: RCV ECD PARAMETER INFO page displayed with cursor at 1.
database_name
 - (j) Type and enter: **incore**
Response: 2. review only
 - (k) Type and enter: **n**
Response: 3. journaling
 - (l) Type and enter: *****
Response: RCV INITIALIZATION IN PROGRESS message displayed.
UNIX RTR RCV (ODIN) - Data Entry page displayed. Cursor
at Enter Form Name:
2. Enter high-level forms.

1. Registered trademark in the United States and other countries, licensed exclusively through X/Open Company, Limited.

- (a) Type and enter: **toggle**
Response: Will take you to the high-level forms.
3. Delete virtual TTY controller data.
Note: An ! may be entered any time prompted to abort the form and return to the state when the form was started.
 - (a) Type and enter: **vttycdel**
Response: vttycdel form displayed. Cursor at 1. ttyc_name:
 - (b) Type and enter: **VTTYCx**
Where: x = VTTYC0 - VTTYC10, VTTYC30 - VTTYC34
Note: To see a list of equipped VTTYCs, at a selected terminal, type and enter the command: **OP:CFGSTAT:VIOP;**.
 - (c) Type and enter: **d**
 - (d) First prompt: Remove VTTYC x from service. Enter CARRIAGE RETURN to continue. At DRM MCC terminal, type and enter command: **RMV:VTTYC=x**
Where: x = VTTYC number.
Response: RMV VTTYC x COMPLETED
 - (e) Second prompt: Remove VIOP/VTTYC x from service. Enter CARRIAGE RETURN to continue. At DRM MCC terminal, type and enter command: **RMV:[VIOP,VTTYC]=x**
Where: x = VIOP/VTTYC number of the previous logical unit.
Response: RMV [VIOP,VTTYC] x COMPLETED
 - (f) Third prompt: Restore VTTYC x to service. Enter CARRIAGE RETURN to continue. At DRM MCC terminal, type and enter command: **RST:VTTYC=x**
Where: x = VTTYC number of the previous logical unit.
Response: RST VTTYC x COMPLETED
Note: During the degrowth of the last VTTYC, the VIOP 0 low-level forms will automatically be deleted and there will be no prompt to restore previous logical unit.
 - (g) The low-level forms will now be deleted automatically.
4. Exit high-level forms.
 - (a) Type and enter: **<**
Response: Exit the vttycdel form UNIX RTR RCV (ODIN) - Data Entry page displayed. Cursor at Enter Form Name:
 - (b) Type and enter: **toggle**
Response: Will take you to the low-level forms.
5. Backup Incore ECD to disk.

- (a) Type and enter: **activate**
Response: Activate form displayed with cursor at 1.copy_inc_to_disk:YES
 - (b) Enter CARRIAGE RETURN
Response: ODIN will request the action desired.
 - (c) Type and enter: **e**
Response: ODIN returns to the UNIX RTR (ODIN) - Data Entry page.
 - (d) Type and enter: **<**
Response: RCV ECD COMPLETED
6. Backup Primary Disk.
It is recommended that primary disk be backed up and that a shelf copy of the disks be made.
7. **STOP. YOU HAVE COMPLETED THIS PROCEDURE.**

8.16 Perform Virtual TTY Degrowth

OVERVIEW

This procedure is used to degrow a virtual TTY. For more information, see 235-600-XXX, **5ESS**[®] *Switch ECD/SG Database Manual*.

PROCEDURE

1. Enter *UNIX*¹ RTR Recent Change and Verify.
 - (a) Is MCC or STLWS terminal to be used?
For MCC, proceed to Step **b**.
For STLWS proceed to Step **i**.
 - (b) At MCC, ensure terminal is in command mode.
 - (c) At MCC, do Steps **d** through **h**.
 - (d) Type and enter: **199**
Response: RCV PARAMETER INFO page displayed with cursor at 1.
database_name
 - (e) Type and enter: **incore**
Response: 2. review only
 - (f) Type and enter: **n**
Response: 3. journaling
 - (g) Type and enter: *****
Response: RCV INITIALIZATION IN PROGRESS message displayed.
UNIX RTR RCV (ODIN) - Data Entry page displayed.
 - (h) You have completed Enter *UNIX* RTR Recent Change and Verify, proceed to Step **2**.
 - (i) At STLWS terminal, type and enter: **RCV:MENU:DATA,RCVECD**
Response: RCV ECD PARAMETER INFO page displayed with cursor at 1.
database_name
 - (j) Type and enter: **incore**
Response: 2. review only
 - (k) Type and enter: **n**
Response: 3. journaling
 - (l) Type and enter: *****
Response: RCV INITIALIZATION IN PROGRESS message displayed.
UNIX RTR RCV (ODIN) - Data Entry page displayed. Cursor
at Enter Form Name:
2. Enter high-level forms.

1. Registered trademark in the United States and other countries, licensed exclusively through X/Open Company, Limited.

- (a) Type and enter: **toggle**

Response: Will take you to the high-level forms.

3. Delete virtual TTY data.

Note: An ! may be entered any time prompted to abort the form and return to the state when the form was started.

- (a) Type and enter: **vttysel**

Response: vttysel form displayed. Cursor at 1.vtty_name:

- (b) Type and enter: TTY name (see the following **TTY NAMES** list).

Response: Remaining fields will automatically be completed.

Note: To see a list of equipped VTTYs, at a selected terminal, type and enter the command: **OP:CFGSTAT:VIOP;**

TTY NAMES

VTTY0 or tty!
VTTY2 or tty#
VTTY7 or ttyh or VTRAFFPRT
VTTY9 or ttyj
VTTY10 or ttyk
VTTY11 or ttyl
VTTY12 or ttym
VTTY13 or ttyn
VTTY14 or ttyo
VTTY22 or ttyw
VTTY23 or tty8 or VBALANCE
VTTY28 or ttyC
VTTY29 or ttyD
VTTY30 or ttyE
VTTY31 or ttyF
VTTY32 or ttyG
VTTY33 or ttyH
VTTY34 or ttyI
VTTY43 or ttyR or VOFFRECPRT
VTTY45 or ttyT or VCOT
VTTY50 or ttyY
VTTY56 or tty%
VTTY57 or tty'
VTTY58 or tty&
VTTY59 or tty(
VTTY60 or tty_
VTTY61 or tty[
VTTY62 or ttyJ
VTTY63 or ttyV
VTTY64 or ttyW
VTTY65 or ttyX
VTTY66 or ttyZ

- (c) Type and enter: **d**

- (d) First prompt: Remove VTTYC x from service. Enter CARRIAGE RETURN to continue. At DRM MCC terminal, type and enter command:

RMV:VTTYC=x

Where: x = VTTYC number.

Response: RMV VTTYC x COMPLETED

- (e) Second prompt: Restore VTTYC x from service. Enter CARRIAGE RETURN to continue. At DRM MCC terminal, type and enter command:
RST:VTTYC=x
Where: x = VTTYC number.
Response: RST VTTYC x COMPLETED
- (f) The low-level forms will now be deleted automatically.
- 4. Exit high-level forms.
 - (a) Type and enter: <
Response: Exit the vttydel form UNIX RTR RCV (ODIN) - Data Entry page displayed. Cursor at Enter Form Name:
 - (b) Type and enter: **toggle**
Response: Will take you to the low-level forms.
- 5. Backup Incore ECD to disk.
 - (a) Type and enter: **activate**
Response: Activate form displayed with cursor at 1.copy_inc_to_disk:YES
 - (b) Enter CARRIAGE RETURN
Response: ODIN will request the action desired.
 - (c) Type and enter: **e**
Response: ODIN returns to the UNIX RTR (ODIN) - Data Entry page.
 - (d) Type and enter: <
Response: RCV ECD COMPLETED
- 6. Backup Primary Disk.
It is recommended that primary disk be backed up and that a shelf copy of the disks be made.
- 7. **STOP. YOU HAVE COMPLETED THIS PROCEDURE.**

8.17 Perform STLWS Degrowth

PROCEDURE

1. Remove TTY x from service. At MCC, type and enter the appropriate message:

RMV:TTY=x

Where: x = appropriate TTY number.

Response: RMV TTY x COMPLETED

2. Enter *UNIX*¹ RTR Recent Change and Verify.

- (a) Is MCC or STLWS terminal to be used?

For MCC, proceed to Step **b**

For STLWS proceed to Step **i**.

- (b) At MCC, ensure terminal is in command mode.

- (c) At MCC, do Steps **d** through **h**.

- (d) Type and enter: **199**

Response: RCV PARAMETER INFO page displayed with cursor at 1.
database_name

- (e) Type and enter: **incore**

Response: 2. review only

- (f) Type and enter: **n**

Response: 3. journaling

- (g) Type and enter: *****

Response: RCV INITIALIZATION IN PROGRESS message displayed.
UNIX RTR RCV (ODIN) - Data Entry page displayed.

- (h) You have completed Enter *UNIX* RTR Recent Change and Verify, proceed to Step **3**.

- (i) At STLWS terminal, type and enter: **RCV:MENU:DATA,RCVECD**

Response: RCV ECD PARAMETER INFO page displayed with cursor at 1.
database_name

- (j) Type and enter: **incore**

Response: 2. review only

- (k) Type and enter: **n**

Response: 3. journaling

- (l) Type and enter: *****

Response: RCV INITIALIZATION IN PROGRESS message displayed.
UNIX RTR RCV (ODIN) - Data Entry page displayed. Cursor
at Enter Form Name:

3. Enter high-level forms.

1. Registered trademark in the United States and other countries, licensed exclusively through X/Open Company, Limited.

- (a) Type and enter: **toggle**
Response: Will take you to the high-level forms.
- 4. Delete TTY data.
 - (a) Type and enter: **ttydel**
Response: ttydel form displayed. Cursor at 1.tty_name:
 - (b) Type and enter the key value for the identified degrowth unit: **TTY9-TTY14, TTY28-TTY34, or TTY50.**
Response: Remainder of fields will automatically be completed.
 - (c) Type and enter: **d**
Note: When degrowing a TTY terminal a defensive check failure message REPT CONFIG FAULT Assert = 412 may be received. This failure message may be ignored.
 - (d) The low level forms will now be deleted automatically, and the user will be prompted to perform certain functions.
 - (e) Type and enter: **<**
Response: Exit the ttydel form.
 - (f) Type and enter: **<**
Response: Exit this recent change session.
If a TAU is not being degrown with the STLWS, continue with Step 10.
- 5. Delete trunk group members associated with the TAU.
 - (a) Select and prepare terminal for Recent Change and Verify activities.
 - 1. Is MCC or STLWS terminal to be used?
If MCC, proceed to substep **a2**. If STLWS, proceed substep **a9**.
 - 2. At MCC, ensure terminal is in command mode.
 - 3. At MCC, do Steps **a4** to **a8**.
 - 4. Type and enter: **196**
Response: **RCV PARAMETER INFO** page displayed with cursor at PRINT OPTION.
 - 5. Type and enter: **Y**
Response: Cursor at DETAIL OPTION
 - 6. Type and enter: **N**
Response: Cursor at VERBOSE OPTION
 - 7. Type and enter: **Y**
Response: **RECENT CHANGE AND VERIFY CLASSES** menu page displayed.

8. You have completed the Select and Prepare Terminal for the MCC, proceed to Step **b**.
9. At the RC/V terminal, type and enter the following message:
RCV:MENU:APPRC:VERBOSE,PRINT
Response: **RECENT CHANGE AND VERIFY CLASS** menu page displayed.
 - (b) Type and enter: **5.5**
Response: Enter Database Operation
I=Insert, R=Review, U=Update, D=Delete
 - (c) Type and enter: **d**
TRUNK MEMBER page displayed. Cursor at TGN attribute.
 - (d) Input the appropriate TGN and MEMB NBR:
Response: System completes remainder of view.
Enter Delete, Change, Validate, or Print:
 - (e) Type and enter: **d**
Response: Deleting...FORM Deleted TRUNK MEMBER page displayed.
Cursor at TGN attribute
 - (f) Repeat Steps **b** through **e** for each member number. This deletion may have to be done four times because there can be two MEMB NBR entries for both ac and dc jacks
 - (g) Type and enter: **<**
Response: 5.0 TRUNKS — TGN & MEMBER VIEWS page displayed.
6. Delete the STLWS trunk group.
 - (a) Type and enter: **5.1**
Response: Enter Database Operation
I=Insert, R=Review, U=Update, D=Delete
 - (b) Type and enter: **d**
Response: TRUNK GROUP page displayed. Cursor at TGN attribute.
 - (c) Type and enter the appropriate TGN
Response: System completes remainder of view.
Enter Delete, Change, Validate, or Print:
 - (d) Type and enter: **d**
Response: Deleting.....FORM DELETED TRUNK GROUP page displayed.
Cursor at TGN attribute.
 - (e) Type and enter: **<**
Response: 5.0 TRUNKS — TGN & MEMBER VIEWS page displayed.
 - (f) Type and enter: **q**
7. Remove the AC and DC jacks.

If the talk and monitor hardware is not being degrown, continue with Step 10.

8. Delete the T/M number.
 - (a) Select and prepare terminal for Recent Change and Verify activities.
Response: Step 6a, substeps 1 through 9.
 - (b) Type and enter: **1.1**
Response: Enter Database Operation
I=Insert, R=Review, U=Update, D=Delete
 - (c) Type and enter: **d**
Response: INDIVIDUAL LINE (LINE ASSIGNMENT) page displayed.
Cursor at TN attribute.
 - (d) Type and enter the appropriate TN.
Response: System completes remainder of view. Enter Delete, Change, Validate, or Print:
 - (e) Type and enter: **d**
Response: Deleting...FORM DELETED INDIVIDUAL LINE (LINE ASSIGNMENT) page displayed. Cursor at TN attribute.
 - (f) Type and enter: **<**
Response: 1.0 LINES — TN VIEWS page displayed.
9. Remove Talk and Monitor (T/M) telephone hardware.
10. Update STLWS office data.
 - (a) Select and prepare terminal for Recent Change and Verify activities.
Reference: Step 6a, substeps 1 through 9.
 - (b) Type and enter: **14.3**
Response: Enter Database Operation
I=Insert, R=Review, U=Update, D=Delete
 - (c) Type and enter: **u**
Response: TRUNK LINE WORK STATION page displayed. Cursor at DEVICE ID attribute.
 - (d) Type and enter the appropriate DEVICE ID.
Response: System completes remainder of view.
Enter Update, Change, Validate, or Print:
 - (e) Type and enter: **c**
Response: Change Field:
 - (f) Update this view as required.
Response: Enter Update, Change, Validate, or Print:
 - (g) Type and enter: **u**
Response: updating.....FORM UPDATED TRUNK LINE WORK STATION page displayed.

- (h) Type and enter: <
Response: 14.0 LINE & TRUNK TEST VIEWS page displayed.
- 11. Backup Incore ECD to disk.
 - (a) At MCC, do Steps **b** through **i**.
 - (b) Type and enter: **199**
Response: RCV PARAMETER INFO page displayed with cursor at 1.
database_name
 - (c) Type and enter: **incore**
Response: 2. review only
 - (d) Type and enter: **n**
Response: 3. journaling
 - (e) Type and enter: *****
Response: UNIX RTR (ODIN) - Data Entry page displayed.
 - (f) Type and enter: **activate**
Response: activate form displayed with cursor at 1. copy_inc_to_disk:
 - (g) Type and enter: **yes**
Response: ODIN will request the action desired.
 - (h) Type and enter: **e**
Response: ODIN returns to the UNIX RTR (ODIN) - Data Entry page.
 - (i) Type and enter: <
Response: RCV MENU RCV ECD COMPLETED
- 12. Backup Office Dependent Data.

Note: Prior to the response there will be completed responses for the switching module and the AM.

 - a. At MCC, type and enter: **BKUP:ODD**
Response: **BKUP ODD COMPLETED**

It is recommended that primary disk be backed up and that a shelf copy of the disks be made.
- 13. **STOP. YOU HAVE COMPLETED THIS PROCEDURE.**

8.18 Perform RC/V Terminal Degrowth

PROCEDURE

1. Change Security

- (a) At MCC, type and enter:

SET:RCACCESS,TTY=a,ACCESS=b

Where: a = ttys, ttyt, or ttyv

Where: ttys = TTY18
ttyt = TTY19
ttyv = TTY21

Where b is obtained from INPUT/OUTPUT manual.

- (b) To check on the access code, type and enter message:

OP:RCACCESS,TTY=a

Where: a = ttys, ttyt, or ttyv

Where: ttys = TTY18
ttyt = TTY19
ttyv = TTY21

Response: Access code returned in hexadecimal

2. Remove TTY x from service.

- (a) At MCC, type and enter the appropriate message:

Where: x = appropriate TTY number.

Response: RMV TTY x COMPLETED

3. Enter *UNIX*¹ RTR Recent Change and Verify.

- (a) Is MCC or STLWS terminal to be used?

For MCC, proceed to Step **b**.

For STLWS proceed to Step **i**.

- (b) At MCC, ensure terminal is in command mode.

- (c) At MCC, do Steps **d** through **h**.

- (d) Type and enter: **199**

Response: RCV PARAMETER INFO page displayed with cursor at 1.
database_name

- (e) Type and enter: **incore**

Response: 2. review only

- (f) Type and enter: **n**

Response: 3. journaling

1. Registered trademark in the United States and other countries, licensed exclusively through X/Open Company, Limited.

- (g) Type and enter: *
Response: RCV INITIALIZATION IN PROGRESS message displayed.
UNIX RTR RCV (ODIN) - Data Entry page displayed.
 - (h) You have completed Enter *UNIX* RTR Recent Change and Verify, proceed to Step 4.
 - (i) At STLWS terminal, type and enter: **RCV:MENU:DATA,RCVECD**
Response: RCV ECD PARAMETER INFO page displayed with cursor at 1.
database_name
 - (j) Type and enter: **incore**
Response: 2. review only
 - (k) Type and enter: **n**
Response: 3. journaling
 - (l) Type and enter: *
Response: RCV INITIALIZATION IN PROGRESS message displayed.
UNIX RTR RCV (ODIN) - Data Entry page displayed. Cursor
at Enter Form Name:
4. Enter high-level forms.
- (a) Type and enter: **toggle**
Response: Will take you to the high-level forms.
5. Delete TTY data.
- (a) Type and enter: **ttydel**
Response: ttydel form displayed. Cursor at 1.tty_name:
 - (b) Type and enter the key value for the identified degrowth unit: **TTY18**, **TTY19**, or **TTY21**.
Response: Remainder of fields will automatically be completed.
 - (c) Type and enter: **d**
Note: When degrowing a TTY terminal a defensive check failure message REPT CONFIG FAULT Assert = 412 may be received. This failure message may be ignored.
 - (d) The low level forms will now be deleted automatically, and the user will be prompted to perform certain functions.
 - (e) Type and enter: **<**
Response: Exit the ttydel form.
 - (f) Type and enter: **<**
Response: Exit this recent change session.
6. Backup Incore ECD to disk.
- (a) At MCC, do Steps **b** through **i**.

- (b) Type and enter: **199**
Response: RCV PARAMETER INFO page displayed with cursor at 1.
database_name
 - (c) Type and enter: **incore**
Response: 2. review only
 - (d) Type and enter: **n**
Response: 3. journaling
 - (e) Type and enter: *****
Response: UNIX RTR (ODIN) - Data Entry page displayed.
 - (f) Type and enter: **activate**
Response: activate form displayed with cursor at 1. copy_inc_to_disk:
 - (g) Type and enter: **yes**
Response: ODIN will request the action desired.
 - (h) Type and enter: **e**
Response: ODIN returns to the UNIX RTR (ODIN) - Data Entry page.
 - (i) Type and enter: **<**
Response: RCV MENU RCV ECD COMPLETED
7. Backup Office Dependent Data.
- Note:** Prior to the response there will be completed responses for the switching module and the AM.
- (a) At MCC, type and enter: **BKUP:ODD**
Response: BKUP ODD COMPLETED
It is recommended that the primary disk be backed up and that a shelf copy of the disks be made.
8. **STOP. YOU HAVE COMPLETED THIS PROCEDURE.**

8.19 Perform SCC Data Link Degrowth

PROCEDURE

1. Type and enter: **incore**
Response: 2. review only
2. Type and enter: **n**
Response: 3. journaling
3. Type and enter: *****
Response: Enter Form Name:
4. Type and enter: **toggle**
Response: Enter Form Name:
High-level mode displayed.
5. Type and enter: **sdlidel**
Response: 1. sdl_name
6. Type and enter: **SCC** or **SDL1**
Remainder of fields will automatically be populated.
Response: Enter Delete, Validate . . .
7. Type and enter: **d**
The low-level forms will now be deleted automatically and you will be prompted to perform certain functions.
Response: 1. sdl_name
8. Type and enter: **<**
Response: Enter Form Name:
9. Type and enter: **<**
Response: Exit this recent change session.
10. To verify SDL1 has been deleted, view the **113** page. SDL1 should not appear on this page.
Note 1: To save the incore ECD changes made in Steps **1** through **9**, execute Steps **15** through **22**, otherwise continue with Step **11**.
Note 2: SCC must also be degrown into the MIN ECD. Execute Steps **11** through **14** to test the MIN ECD degrowth capability.
11. Type and enter: **199**
Response: RCV PARAMETER INFO page displayed with cursor at 1.
database_name
12. Type and enter: **rootdmly**
Response: 2. review only
13. Repeat Steps **2** through **9**.
14. Save Incore ECD changes to disk:

- Type and enter: **199**
Response: RCV PARAMETER INFO page displayed with cursor at 1.
database_name
15. Type and enter: **incore**
Response: 2. review only
16. Type and enter: **n**
Response: 3. journaling
17. Type and enter: *****
Response: Enter Form Name:
18. Type and enter: **activate**
Response: 1. copy_inc_to_disk:
19. Enter CARRIAGE RETURN
Response: Enter Execute, Change. . .
20. Type and enter: **e**
Response: Enter Form Name:
21. Type and enter: **<**
Response: Exit this recent change session.
22. **STOP. YOU HAVE COMPLETED THIS PROCEDURE.**

8.20 Perform Traffic Printer Degrowth

PROCEDURE

1. Remove TTY x from service.
 - (a) At MCC, type and enter the appropriate message:
RMV:TTY=x
Where: x = appropriate TTY number.
Response: RMV TTY x COMPLETED
2. Enter *UNIX*¹ RTR Recent Change and Verify.
 - (a) Is MCC or STLWS terminal to be used?
For MCC, proceed to Step **b**.
For STLWS proceed to Step **i**.
 - (b) At MCC, ensure terminal is in command mode.
 - (c) At MCC, do Steps **d** through **h**.
 - (d) Type and enter: **199**
Response: RCV PARAMETER INFO page displayed with cursor at 1.
database_name
 - (e) Type and enter: **incore**
Response: 2. review only
 - (f) Type and enter: **n**
Response: 3. journaling
 - (g) Type and enter: *****
Response: RCV INITIALIZATION IN PROGRESS message displayed.
UNIX RTR RCV (ODIN) - Data Entry page displayed.
 - (h) You have completed Enter *UNIX* RTR Recent Change and Verify, proceed to Step **3**.
 - (i) At STLWS terminal, type and enter: **RCV:MENU:DATA,RCVECD**
Response: RCV ECD PARAMETER INFO page displayed with cursor at 1.
database_name
 - (j) Type and enter: **incore**
Response: 2. review only
 - (k) Type and enter: **n**
Response: 3. journaling
 - (l) Type and enter: *****
Response: RCV INITIALIZATION IN PROGRESS message displayed.
UNIX RTR RCV (ODIN) - Data Entry page displayed. Cursor
at Enter Form Name:

1. Registered trademark in the United States and other countries, licensed exclusively through X/Open Company, Limited.

3. Enter high-level forms.
 - (a) Type and enter: **toggle**
Response: Will take you to the high-level forms.
4. Delete TTY data.
 - (a) Type and enter: **ttydel**
Response: ttydel form displayed. Cursor at 1.tty_name:
 - (b) Type and enter: **TTY7**
Response: Remaining fields will automatically be completed.
 - (c) Type and enter: **d**
Note: When degrowing a TTY terminal a defensive check failure message REPT CONFIG FAULT Assert = 412 may be received. This failure message may be ignored.
 - (d) The low-level forms will now be deleted automatically, and the user will be prompted to perform certain functions.
 - (e) Type and enter: **<**
Response: Exit the ttydel form.
 - (f) Type and enter: **<**
Response: Exit this recent change session.
5. Backup Incore ECD to disk.
 - (a) At MCC, do Steps **b** through **i**.
 - (b) Type and enter: **199**
Response: RCV PARAMETER INFO page displayed with cursor at 1. database_name
 - (c) Type and enter: **incore**
Response: 2. review only
 - (d) Type and enter: **n**
Response: 3. journaling
 - (e) Type and enter: *****
Response: UNIX RTR (ODIN) - Data Entry page displayed.
 - (f) Type and enter: **activate**
Response: activate form displayed with cursor at 1. copy_inc_to_disk:
 - (g) Type and enter: **yes**
Response: ODIN will request the action desired.
 - (h) Type and enter: **e**
Response: ODIN returns to the UNIX RTR (ODIN) - Data Entry page.
 - (i) Type and enter: **<**
Response: RCV MENU RCV ECD COMPLETED

6. Backup Office Dependent Data.

Note: Prior to the response there will be completed responses for the switching module and the AM.

(a) At MCC, type and enter: **BKUP:ODD**

Response: BKUP ODD COMPLETED

It is recommended that primary disk be backed up and that a shelf copy of the disks be made.

7. **STOP. YOU HAVE COMPLETED THIS PROCEDURE.**

8.21 Perform Office Record Printer Degrowth

PROCEDURE

1. Remove TTY x from service.
 - (a) At MCC, type and enter the appropriate message:
RMV:TTY=x
Where: x = appropriate TTY number.
Response: RMV TTY x COMPLETED
2. Enter *UNIX*¹ RTR Recent Change and Verify.
 - (a) Is MCC or STLWS terminal to be used?
For MCC, proceed to Step **b**.
For STLWS proceed to Step **i**.
 - (b) At MCC, ensure terminal is in command mode.
 - (c) At MCC, do Steps **d** through **h**.
 - (d) Type and enter: **199**
Response: RCV PARAMETER INFO page displayed with cursor at 1.
database_name
 - (e) Type and enter: **incore**
Response: 2. review only
 - (f) Type and enter: **n**
Response: 3. journaling
 - (g) Type and enter: *****
Response: RCV INITIALIZATION IN PROGRESS message displayed.
UNIX RTR RCV (ODIN) - Data Entry page displayed.
 - (h) You have completed Enter *UNIX* RTR Recent Change and Verify, proceed to Step **3**.
 - (i) At STLWS terminal, type and enter: **RCV:MENU:DATA,RCVECD**
Response: RCV ECD PARAMETER INFO page displayed with cursor at 1.
database_name
 - (j) Type and enter: **incore**
Response: 2. review only
 - (k) Type and enter: **n**
Response: 3. journaling
 - (l) Type and enter: *****
Response: RCV INITIALIZATION IN PROGRESS message displayed.
UNIX RTR RCV (ODIN) - Data Entry page displayed. Cursor
at Enter Form Name:

1. Registered trademark in the United States and other countries, licensed exclusively through X/Open Company, Limited.

3. Enter high-level forms.
 - (a) Type and enter: **toggle**
Response: Will take you to the high-level forms.
4. Delete TTY data.
 - (a) Type and enter: **ttydel**
Response: ttydel form displayed. Cursor at 1.tty_name:
 - (b) Type and enter: **TTY43**
Response: Remaining fields will automatically be completed.
 - (c) Type and enter: **d**
Note: When degrowing a TTY terminal a defensive check failure message REPT CONFIG FAULT Assert = 412 may be received. This failure message may be ignored.
 - (d) The low-level forms will now be deleted automatically, and the user will be prompted to perform certain functions.
 - (e) Type and enter: **<**
Response: Exit the ttydel form.
 - (f) Type and enter: **<**
Response: Exit this recent change session.
5. Backup Incore ECD to disk.
 - (a) At MCC, do Steps **b** through **i**.
 - (b) Type and enter: **199**
Response: RCV PARAMETER INFO page displayed with cursor at 1. database_name
 - (c) Type and enter: **incore**
Response: 2. review only
 - (d) Type and enter: **n**
Response: 3. journaling
 - (e) Type and enter: *****
Response: UNIX RTR (ODIN) - Data Entry page displayed.
 - (f) Type and enter: **activate**
Response: activate form displayed with cursor at 1. copy_inc_to_disk:
 - (g) Type and enter: **yes**
Response: ODIN will request the action desired.
 - (h) Type and enter: **e**
Response: ODIN returns to the UNIX RTR (ODIN) - Data Entry page.
 - (i) Type and enter: **<**
Response: RCV MENU RCV ECD COMPLETED

6. Backup Office Dependent Data.

Note: Prior to the response there will be completed responses for the switching module and the AM.

(a) At MCC, type and enter: **BKUP:ODD**

Response: BKUP ODD COMPLETED

It is recommended that primary disk be backed up and that a shelf copy of the disks be made.

7. **STOP. YOU HAVE COMPLETED THIS PROCEDURE.**

A1. SUN¹ CONSOLE/MASTER CONTROL CENTER (MCC) TERMINAL SETTINGS

A1.1 Overview

Table A1-1 lists terminal settings that should be set when growing a KS-23996 *Sun* console or MCC terminal. Table A1-1 should also be used to verify terminal option settings in the case of a terminal lock-up.

Table A1-1 — KS-23996 Sun Console/MCC Terminal Settings

Session 1 (MCC-EIA)		
F1 Screen		
Emulation = VT100	Comm Mode = Full Duplex	EIA Baud Rate = 9600
Aux Baud Rate = 9600	Enhanced = off	EIA Data Format = 7/1/E
Format = 8/1/N	Sessions = 2	Host/Printer = EIA/None
F2 Screen		
Emulation = VT100	Enhanced = off	Auto Wrap = on
Auto Font Load = on	Auto Pager = off	Auto Scroll = on
Monitor Mode = off	Screen Saver = off	Bell Volume = 09
Warning Bell = on	Host/Printer = EIA/None	Sessions = 2
Session 2 (Sun Console-AUX)		
F1 Screen		
Emulation = VT100	Comm Mode = Full Duplex	EIA Baud Rate = 9600
Aux Baud Rate = 9600	Enhanced = off	EIA Data Format = 7/1/E
Format = 8/1/N	Sessions = 2	Host/Printer = AUX/None
F2 Screen		
Emulation = VT100	Enhanced = off	Auto Wrap = on
Auto Font Load = on	Auto Pager = off	Auto Scroll = on
Monitor Mode = off	Screen Saver = off	Bell Volume = 09
Warning Bell = on	Host/Printer = AUX/None	Sessions = 2
Session 1/2		
F3 Screen		
Page Length = 24	Screen Length = 26 Lines	Screen Video = Normal
Display Cursor = on	Cursor = Steady Black	Auto Adjust Cursor = on
Columns = 80	Width Change Clear = off	Speed = Normal
F4 Screen		
Char Set Mode = ANSI	Key Mode = ASCII	Keyclick = off
Key Repeat = off	Margin Bell = off	Key Lock = Caps
F5 Screen		
Enter Key = <CR>	Return Key = <CR>	Backspace = <BS>/<BS>
Alt Key = Alt	,< and .> = < and .>	Esc Key = Esc
'~ Key = ' and ~	F1 to F5 Keys = Fkeys	Pound Key = U.S.
F6 Screen		

1. Registered trademark of Sun Microsystems, Inc.

Table A1-1 — KS-23996 Sun Console/MCC Terminal Settings (Contd)

EIA Baud Rate = 9600	EIA Data Format = 7/1/E	EIA Parity Check = off
Aux Baud Rate = 9600	Aux Data Format = 8/1/N	Aux Parity Format = off
EIA Xmt = Xon-Xoff	EIA Recv = Xon-Xoff (XPC)	EIA Xmt Pace = Baud
Aux Xmt = Xon-Xoff	Aux Recv = Xon-Xoff (XPC)	Aux Xmt Pace = Baud
EIA Break = 250 ms	EIA Modem Control = off	EIA Disconnect = 60 ms
Aux Break = 250 ms	Aux Modem Control = off	Aux Disconnect = 60 ms
F7 Screen		
Comm Mode = Full Duplex	Local = off	Recv <CR> = <CR>
Recv = Destruct BS	Send ACK = off	Send Block Term = None
Send Region = Screen	Send End = Region	Null Suppress = on
F8 Screen		
Prnt Mode = Normal	Prnt Region = Screen	Prnt Block Term = None
Secondary Recv = off		
F9 Screen		
Numeric Kpd = Numeric	Cursor Kpd = Cursor	Send Data = All
Print = Multinational	ANSI-ID = VT100	Function Key Lock = on
UPSS = ANSI-Supplemental	Feature Lock = off	Status Line = off
F11 Screen		
Answerback Mode = off		
F12 Screen		
Key = F1	Program = F/Key	Key Dir = Comm Dependent
<p>Note: To get into the options page press CNTL-ALT-F3. Toggle between sessions with CNTL Enter (on numeric pad). To exit press F14.</p>		

Table A1-2 lists terminal settings that should be set when growing a KS-249697 Sun Console or MCC terminal. Table A1-2 should also be used to verify terminal option settings in case of a terminal lock-up.

Table A1-2 — KS-24697 Sun Console/MCC Terminal Settings

Field Name	Value
Name	Unix
Serial Port	/dev/ttyS0
Baud	9600
Data Bits	8
Stop Bits	1
Parity	None
Note: To get into the options page press CTRL-SHIFT-S to open the settings menu, then go to Communications Setup by highlighting “Communications” and then enter. If Serial Host is not Unix , tab to Cancel and hit enter then CTRL-ENTER to toggle sessions and start over. Tab to Configure then enter. To save the settings, tab to OK and hit enter on both menus. If no output is given, enter a ^Q(CTRL_Q) and hit return a couple of times.	

A2. PROCESSOR RECOVERY MESSAGES

A2.1 Overview

This appendix is a guide to Processor Recovery Messages (PRMs) unique to the DRM initialization and recovery. For a complete listing of PRMs, consult 235-600-601, **5ESS**[®] *Switch Processor Recovery Messages*. The following list of PRMs are described in this section:

5F06 FF05
60xx FF06
CB00 FF1B
FF03 FF1F

This section will help the user interpret the messages and correct faults.

Processor Recovery Messages are one-line, fixed-format messages that use hexadecimal notation to print critical switch initialization and recovery information. PRMs are associated with the recovery of the following system entities: AM and CM2/CMP.

PRMs are not associated with the recovery of the switching module. The switching module initialization information is displayed via MCC display pages.

PRMs are printed on the ROP and on the Emergency Action Interface (EAI) page at the MCC.

PRMs are used to report various events associated with AM initializations and AM fault recovery. The types of events reported include:

- Successful beginning or end of an initialization step.
- Failure of a software initialization step.
- An initialization phase trigger (that is, high-level reason for initializing).
- An ASSERT or error report.
- Lack of AM resources (for example, real time or message buffers).

Each PRM is associated with a unique five-digit key that appears at the top of the PRM's page.

When a digit in a key position is a literal, that is, will never change value, it is shown in uppercase in the key. When a digit in a key position is variable, it may change values, it is written in lowercase. The lowercase v is usually reserved for the special case of a variable in the first letter of the format, such as in the following example:

```
PRM_p EEEda 5F06 xxxx yzzz hh hh hh
```

If the leading character of a PRM identifier is E, as in the previous example, then it reports problems that do not involve AM initialization.

If the leading character of the identifier is F, then it reports a problem that usually involves system-wide initialization.

If the leading character is a v, then some versions of that PRM message begin with either an E or an F.

Each PRM listing provides the following information:

Format - Shows format of possible outputs for this PRM.

Source - Lists software program originating the PRM

Function - Details why the PRM was generated.

Expansion - Defines all variables used in the PRM

Explanation - Provides additional information about the PRM.

Corrective Action - Gives instructions on corrective measures available or reference to other documents.

If software inhibits are turned on, the switch may have lost critical functionality and this fact may not be readily apparent. For more information, see 235-105-250, **5ESS Switch System Recovery Manual**.

During a processor recovery, each common *UNIX*¹ RTR operating system process produces a 16-digit hexadecimal success or failure PRM after execution. Approximately every 2 seconds, a PRM can be printed out on the MCC and ROP.

Success PRMs are considered low priority and are therefore not always output. However, the system will guarantee that the first (oldest) failure PRM will be output to all devices (MCC and ROP).

If a failure PRM is output, it identifies the process encountering the failure, the reason for the failure, and in some cases, failure information.

A2.2 Processor Recover Messages

A2.2.1 PRM:EE 5F06

A2.2.1.1 PRM Format

PRM_p EEda 5F06 xxxx yzzz hh hh hh

A2.2.1.2 PRM Source

Application Integrity Monitor (AIM).

A2.2.1.3 Function

AIM initialization timeout (associated with the specified *UNIX* RTR operating system application process) occurred, but initialization has completed anyway.

A2.2.1.4 PRM Expansion

1. Registered trademark in the United States and other countries, licensed exclusively through X/Open Company, Limited

- p = Active control unit (CU):
0 — CU 0
1 — CU 1
- E = Informational PRM.
- E = Application software generated this PRM.
- d = Level of most recent *UNIX* RTR operating system initialization:
0 — No initialization or D0 initialization.
1 — D1 initialization.
2 — D2 initialization.
3 — D3 initialization.
4 — D4 initialization.
These initializations are explained in 235-105-250, *5ESS Switch System Recovery Manual*.
- a = Application initialization level within the *UNIX* RTR operating system initialization specified in field 'd'.
- 5F06 = Application function = initialization timeout and completion.
- xxxx = *UNIX* RTR operating system application process utility ID:
017 — First in-first out (FIFO) driver (FDA).
0C0 — Input/output driver (IODRV).
0C2 — Scan and signal distributor administration (SCSD).
0CC — RTR Data Link Driver for DRM
117 — Plant measurement database monitor (PLDMON).
186 — Kernel level overload monitor (KLMON)
188 — *UNIX* RTR operating system supervisor overload monitor process (SUOVPRC).
406 — Process to load ODD onto Disk (PLOD).
407 — Application data link (APDL).
410 — Switch maintenance kernel process (switching module KP).
411 — Switch maintenance power switch monitor (SMPSM).
420 — Communications kernel process (CMKP).
430 — Message switch kernel process (MSKP).
450 — Pump control (PUCR).
451 — Automatic message accounting disk writer (AMDW).
460 — Operational kernel process (OKP).
590 — Process for loading ODD into PAS (PLOP).
710 — Switch Maintenance Diagnostic Input Message Processor (SMDIMP). SMDIMP is also referred to as deferred maintenance administrator and monitor (DMAM).
7ED — Communications Module Processor Kernel Process (CMPKP)
7DD — Automatic message accounting disk writer 1 (AMDW1).
7CE — Automatic message accounting disk writer 2 (AMDW2).
- yy = Failed process sequence state.

		00 — Created (booted from disk).
		01 — Software initialization.
		02 — Hardware initialization.
		03 — Communication link initialization.
		04 — Enable fault recovery.
		05 — Essential jobs operational.
		06 — Fully operational.
		07 — Aborting.
zz	=	Process run state.
		00 — process was still performing initialization step.
		01 — process had completed initialization step.
		02 — process timed out.
hh hh hh	=	Hardware status digits. Refer to Figure A2-1 for definition of the digits.

A2.2.1.5 Explanation

At this point, all *UNIX* RTR operating system application processes should have completed sequencing to the fully operational state. However, the specified process did not. If this is an essential process, the HW/SW inhibits must be on. If so, no initialization will occur; however, the system will not have essential functionality. If this is a non-essential process, the HW/SW inhibit state is a don't care; non-critical functionality is lost and AIM will automatically attempt to Full Process Initialization (FPI) the specified process.

A2.2.1.6 Corrective Action

Monitor the system for lost functionality associated with the specified process. If significant periods of time (that is, several minutes) elapse without this functionality, attempt to manually recover this functionality. The situation should be dealt with as follows: apply Master Control Center (MCC) controls (for example, inhibits); request processor reconfiguration (for example, force CU/Disks); request higher manual initializations (for example, 53); for more information, see 235-105-250, *5ESS Switch System Recovery Manual* or **seek technical assistance**.

A2.2.2 PRM:EE 60XX-B

A2.2.2.1 PRM Format

PRM_a EEbc 60de fggg ijkk hh hh hh

A2.2.2.2 PRM Source

Application Integrity Monitor (AIM).

A2.2.2.3 Function

UNIX RTR operating system application process initialization progress.

A2.2.2.4 PRM Expansion

a	=	Active control unit (CU): 0 — CU 0 1 — CU 1
E	=	Informational PRM.
E	=	Application software generated this PRM.
b	=	Level of most recent UNIX RTR operating system initialization: 0 — No initialization or D0 initialization. 1 — D1 initialization. 2 — D2 initialization. 3 — D3 initialization. 4 — D4 initialization. These initializations are explained in 235-105-250, 5ESS Switch System Recovery Manual .
c	=	Application initialization level within the UNIX RTR Operating System initialization specified in field 'd'.
60	=	Application function = DRM general initialization progress.
d	=	Administrative Module (AM) Software initialization level: 0 — S0 (no AW SW initialization). 2 — S2 (D1 = single process purge (SPP)) on all UNIX RTR operating system application processes). 4 — S4 (CI initialization). 5 — S5 (application full process init (FPI)). 6 — S6 (AM SW init w/o clearing phase protected data.) 7 — S7 (AM SW init with phase protected data cleared.)
e	=	Not significant for DRM.
f	=	Not significant for DRM.
ggg	=	UNIX RTR operating system application process utility ID: 017 — First in-first out (FIFO) driver (FDA). 0C0 — Input/output driver (IODRV). 0C2 — Scan and signal distributor administration (SCSD). 0CC — RTR Data Link Driver for DRM

- 117 — Plant measurement database monitor (PLDMON).
- 186 — Kernel level overload monitor (KLMON)
- 188 — *UNIX* RTR operating system supervisor overload monitor process (SUOVPRC).
- 406 — Process to load ODD onto Disk (PLOD).
- 407 — Application data link (APDL).
- 410 — Switch maintenance kernel process (SMKP).
- 411 — Switch maintenance power switch monitor (SMPSM).
- 420 — Communications kernel process (CMKP).
- 430 — Message switch kernel process (MSKP).
- 450 — Pump control (PUCR).
- 460 — Operational Kernel Process (OKP)
- 590 — Process for loading ODD into PAS (PLOP).
- 710 — Switch Maintenance Diagnostic Input Message Processor (SMDIMP). SMDIMP is also referred to as deferred maintenance administrator and monitor (DMAM).
- 7ED — Communications Module Processor Kernel Process (CMPKP)
- 7DD — Automatic Message Accounting Disk Writer 1 (AMDW1).
- 7CE — Automatic Message Accounting Disk Writer 2 (AMDW2).
- i = Initialization sequence state:
 - 00 — Created (booted from disk).
 - 01 — Software initialization.
 - 02 — Hardware initialization.
 - 03 — Communication link initialization.
 - 04 — Enable fault recovery
 - 05 — Essential jobs operational.
 - 06 — Fully operational.
 - 07 — Aborting
- j = Success/failure indication:
 - 0 — Initialization step completed successfully.
 - 1 — Initialization step failed.
 - 2 — Initialization step timeout.
 - 3 — Initialization step in-progress.
 - 4 — Initialization step not attempted.
 - A — Process abort or re-initialization starting.
 - B — Initialization step beginning (use EAI page poke 42;J;50 to turn on).
 - D — Death of child received for this process.
- kk = Initialization progress points:

00 — Normal operation (no initialization or safe interval).
01 — AIM created.
02 — 5E critical creations requested (phase 1 creations in progress).
03 — DB/DD initialization complete.
06 — SMKP SOFTINIT completed.
07 — MSKP SOFTINIT completed.
08 — OKP SOFTINIT completed.
10 — DRM call processing on.
40 — Call support creations requested (phase 4 creations in progress)
60 — ULARP HM processes created.
80 — ULARP MTCE processes created.
A0 — DRM/*UNIX* RTR operating system non-critical creations requested (phase 5 creations in progress).
E4 — ULARP RC/DB processes created.
F4 — ULARP AS/TM processes created.
FF — ULARP deferred processes created (begin safe interval).

hh hh hh = Hardware status digits. Refer to Figure A2-1 for definition of the digits.

A2.2.2.5 Explanation

AIM prints these PRMs as the *UNIX* RTR operating system application processes complete (or fail to complete) each of their required initialization sequence states.

A2.2.2.6 Corrective Action

None. These PRMs are informational only. Other failure PRMs will be printed if operator actions are required.

A2.2.3 PRM:EE-CB00-B

A2.2.3.1 PRM Format

PRM_p EEda CB00 xxxx yzzz hh hh hh

A2.2.3.2 PRM Source

Application Integrity Monitor (AIM).

A2.2.3.3 Function

AIM *UNIX* RTR operating system application process initialization failure.

A2.2.3.4 PRM Expansion

p	=	Active control unit (CU): 0 — CU 0 1 — CU 1
E	=	Informational PRM.
E	=	Application software generated this PRM.
d	=	Level of most recent <i>UNIX</i> RTR operating system initialization: 0 — No initialization or D0 initialization. 1 — D1 initialization. 2 — D2 initialization. 3 — D3 initialization. 4 — D4 initialization. These initializations are explained in 235-105-250, 5ESS Switch System Recovery Manual .
a	=	Application initialization level within the <i>UNIX</i> RTR operating system initialization specified in field 'd'.
CB00	=	Application function = AIM killable process initialization failure.
xxxx	=	<i>UNIX</i> RTR operating system application process utility ID: 0017 — First in-first out (FIFO) driver (FDA). 00C0 — Input/output driver (IODRV). 00C2 — Scan and signal distributor administration (SCSD). 0CC — RTR Data Link Driver for DRM 0117 — Plant measurement database monitor (PLDMON). 0186 — Kernel level overload monitor (KLMON) 0188 — <i>UNIX</i> RTR operating system supervisor overload monitor process (SUOVPRC). 0406 — Process to load ODD onto Disk (PLOD). 0407 — Application data link (APDL). 0410 — Switch maintenance kernel process (SMKP). 0411 — Switch maintenance power switch monitor (SMPSM).

		0420 — Communications kernel process (CMKP).
		0430 — Message switch kernel process (MSKP).
		0450 — Pump control (PUCR).
		0460 — Operational kernel process (OKP).
		0590 — Process for loading ODD into PAS (PLOP).
		0710 — Switch Maintenance Diagnostic Input Message Processor (SMDIMP). SMDIMP is also referred to as deferred maintenance administrator and monitor (DMAM).
		7ED — Communications Module Processor Kernel Process (CMPKP)
		07DD — Automatic message accounting disk writer 1 (AMDW1).
		07CE — Automatic message accounting disk writer 2 (AMDW2).
yy	=	Failed process sequence state:
		00 — Created (booted from disk).
		01 — Software initialization.
		02 — Hardware initialization.
		03 — Communication link initialization.
		04 — Enable fault recovery.
		05 — Essential jobs operational.
		06 — Fully operational.
		07 — Aborting.
zz	=	Reason for failure.
		0b — initialization time limit exceeded.
		0c — initialization sequence state failed or timed out (INSEQSTFL)
hh hh hh	=	Hardware status digits. Refer to Figure A2-1 for definition of the digits.

A2.2.3.5 Explanation

The AIM process produces this PRM when a killable process reports the failure of an initialization sequence state, or when a killable process times out while initializing.

A2.2.3.6 Corrective Action

The killable process that failed should be re-initialized manually.

A2.2.4 PRM:vE-FF03

A2.2.4.1 PRM Format

PRM_p vEda FF03 yyyy zzzz hh hh hh

A2.2.4.2 PRM Source

Application Integrity Monitor (AIM) Phase Trigger.

A2.2.4.3 Function

Failure of the Process Manager (PMGR) to create an essential process for AIM.

A2.2.4.4 PRM Expansion

p	=	Active control unit (CU): 0 — CU 0 1 — CU 1
v	=	E - Administrative Module (AM) software checks are inhibited (see “Explanation,” Section A2.2.4.5). F - AM software checks allowed. A high level AM initialization will follow immediately.
E	=	Application software generated this PRM.
d	=	Level of most recent <i>UNIX</i> RTR operating system initialization: 0 — No initialization or D0 initialization. 1 — D1 initialization. 2 — D2 initialization. 3 — D3 initialization. 4 — D4 initialization. These initializations are explained in 235-105-250, 5ESS Switch System Recovery Manual .
a	=	Application initialization level within the <i>UNIX</i> RTR operating system initialization specified in field 'd'.
FF03	=	Application function = DRM phase trigger = Process Manager (PMGR) essential process creation failure.
yyyy	=	<i>UNIX</i> RTR operating system application process utility ID: 0017 — First in-first out (FIFO) driver (FDA). 00C0 — Input/output driver (IODRV). 00C2 — Scan and signal distributor administration (SCSD). 0CC — RTR Data Link Driver for DRM 0117 — Plant measurement database monitor (PLDMON). 0186 — Kernel level overload monitor (KLMON) 0410 — Switch maintenance kernel process (SMKP). 0420 — Communications kernel process (CMKP). 0430 — Message switch kernel process (MSKP). 0450 — Pump control (PUCR).

		0455 — Recent Change Kernel Process (RCKP).
		0460 — Operational kernel process (OKP).
		7ED — Communications Module Processor Kernel Process (CMPKP)
zzzz	=	Failed process sequence state: 000A — AIM timed out waiting for a PMGR response. yyyy — PMGR failure code. See <i>UNIX RTR PMGR error codes</i> in Appendix C, 235-600-700, <i>Input Messages Manual</i> , or convert from hexadecimal to decimal and consult the REPT:PMGR output message in 235-600-750, <i>Output Messages Manual</i> , for an explanation.
hh hh hh	=	Hardware status digits. Refer to Figure A2-1 for definition of the digits.

A2.2.4.5 Explanation

AIM prints this PRM to report that it was unable to create an essential process.

If AM software checks are allowed, AIM will immediately trigger a high-level AM initialization. Otherwise, no initialization will occur. However, the system may not support essential functionality (such as call processing, maintenance, or input/output).

A2.2.4.6 Corrective Action

If several minutes elapse without recovery, go into *UNIX RTR* operating system minimum configuration. Using the process manager error code and the process identity, check that the disk files necessary for process creation are in their correct directory locations and contain the correct header information.

If this fails to correct the problem, see “Analyze AM Initialization Failure,” 235-105-250, *5ESS Switch System Recovery Manual*.

A2.2.5 PRM:vE FF05

A2.2.5.1 PRM Format

PRM_p vEda FF05 xxxx yzzz hh hh hh

A2.2.5.2 PRM Source

Application Integrity Monitor (AIM) Phase Trigger.

A2.2.5.3 Function

AIM essential *UNIX RTR* operating system application process initialization failure.

A2.2.5.4 PRM Expansion

p	=	Active control unit (CU): 0 — CU 0 1 — CU 1
v	=	E - Administrative Module (AM) software checks are inhibited (see "Explanation," Section A2.2.5.5). F - AM software checks allowed. A high level AM initialization will follow immediately.
E	=	Application software generated this PRM.
d	=	Level of most recent <i>UNIX</i> RTR operating system initialization: 0 — No initialization or D0 initialization. 1 — D1 initialization. 2 — D2 initialization. 3 — D3 initialization. 4 — D4 initialization. These initializations are explained in 235-105-250, 5ESS <i>Switch System Recovery Manual</i> .
a	=	Application initialization level within the <i>UNIX</i> RTR operating system initialization specified in field 'd'.
FF05	=	Application function = DRM phase trigger = essential process initialization failure.
xxxx	=	<i>UNIX</i> RTR operating system application process utility ID: 0017 — First in-first out (FIFO) driver (FDA). 00C0 — Input/output driver (IODRV). 00C2 — Scan and signal distributor administration (SCSD). 0CC — RTR Data Link Driver for DRM 0117 — Plant measurement database monitor (PLDMON). 0186 — Kernel level overload monitor (KLMON) 0410 — Switch maintenance kernel process (SMKP). 0420 — Communications kernel process (CMKP). 0430 — Message switch kernel process (MSKP). 0455 — Recent Change Kernel Process (RCKP). 0460 — Operational kernel process (OKP). 7ED — Communications Module Processor Kernel Process (CMPKP)
yy	=	Failed process sequence state. 00 — Created (booted from disk). 01 — Software initialization. 02 — Hardware initialization. 03 — Communication link initialization. 04 — Enable fault recovery. 05 — Essential jobs operational.

		06 — Fully operational.
		07 — Aborting.
zz	=	Process run state.
		00 — process was still performing initialization step.
		01 — process had completed initialization step.
		02 — process timed out.
hh hh hh	=	Hardware status digits. Refer to Figure A2-1 for definition of the digits.

A2.2.5.5 Explanation

An essential application process has failed to initialize successfully by either calling `INcomplete ()` indicating a failure or by timing out.

If AM software checks are allowed, AIM will immediately trigger a high-level AM initialization. Otherwise, no initialization will occur. However, the system may not support essential functionality (such as call processing, maintenance, or input/output).

A2.2.5.6 Corrective Action

If several minutes elapse without recovery or escalation to higher levels of initialization, see “Analyze AM Initialization Failure,” 235-105-250, **5ESS Switch System Recovery Manual**.

A2.2.6 PRM:vE FF06

A2.2.6.1 PRM Format

PRM_p vEda FF06 xxxx yzzz hh hh hh

A2.2.6.2 PRM Source

Application Integrity Monitor (AIM) Phase Trigger.

A2.2.6.3 Function

AIM essential *UNIX* RTR operating system application process initialization timeout.

A2.2.6.4 PRM Expansion

p	=	Active control unit (CU):
		0 — CU 0
		1 — CU 1
v	=	E - Administrative Module (AM) software checks are inhibited (see “Explanation,” Section A2.2.6.5).
		F - AM software checks allowed. A high level AM initialization will follow immediately.
E	=	Application software generated this PRM.
d	=	Level of most recent <i>UNIX</i> RTR operating system initialization:
		0 — No initialization or D0 initialization.
		1 — D1 initialization.
		2 — D2 initialization.
		3 — D3 initialization.

		4 — D4 initialization. These initializations are explained in 235-105-250, 5ESS Switch System Recovery Manual .
a	=	Application initialization level within the <i>UNIX</i> RTR operating system initialization specified in field 'd'.
FF06	=	Application function = initialization timeout.
xxxx	=	<i>UNIX</i> RTR operating system application process utility ID: 0017 — First in-first out (FIFO) driver (FDA). 00C0 — Input/output driver (IODRV). 00C2 — Scan and signal distributor administration (SCSD). 0CC — RTR Data Link Driver for DRM 0117 — Plant measurement database monitor (PLDMON). 0186 — Kernel level overload monitor (KLMON) 0410 — Switch maintenance kernel process (SMKP). 0420 — Communications kernel process (CMKP). 0430 — Message switch kernel process (MSKP). 0455 — Recent Change Kernel Process (RCKP) 0460 — Operational kernel process (OKP). 7ED — Communications Module Processor Kernel Process (CMPKP)
yy	=	Failed process sequence state. 00 — Created (booted from disk). 01 — Software initialization. 02 — Hardware initialization. 03 — Communication link initialization. 04 — Enable fault recovery. 05 — Essential jobs operational. 06 — Fully operational. 07 — Aborting.
zz	=	Process run state. 00 — process was still performing initialization step. 01 — process had completed initialization step.
hh hh hh	=	Hardware status digits. Refer to Figure A2-1 for definition of the digits.

A2.2.6.5 Explanation

AIM prints this PRM to report that initialization of an essential process failed to complete within the allotted time.

If AM software checks are allowed, AIM will immediately trigger a high-level AM initialization. Otherwise, no initialization will occur. However, the system may not support essential functionality (such as call processing, maintenance, or input/output).

A2.2.6.6 Corrective Action

If several minutes elapse without recovery or escalation to higher levels of initialization, see “Analyze AM Initialization Failure,” 235-105-250, **5ESS Switch System Recovery Manual**.

A2.2.7 PRM:VE FF1B-B

A2.2.7.1 PRM Format

PRM_p vEda FF1B www xyzz hh hh hh

A2.2.7.2 PRM Source

Application Integrity Monitor (AIM) Phase Trigger.

A2.2.7.3 Function

Essential *UNIX* RTR operating system application process full process initialization (FPI) timeout.

A2.2.7.4 PRM Expansion

p	=	Active control unit (CU): 0 — CU 0 1 — CU 1
v	=	E - Administrative Module (AM) software checks are inhibited (see "Explanation," Section A2.2.7.5). F - AM software checks allowed. A high level AM initialization will follow immediately.
E	=	Application software generated this PRM.
d	=	Level of most recent <i>UNIX</i> RTR operating system initialization: 0 — No initialization or D0 initialization. 1 — D1 initialization. 2 — D2 initialization. 3 — D3 initialization. 4 — D4 initialization. These initializations are explained in 235-105-250, 5ESS Switch System Recovery .
a	=	Application initialization level within the <i>UNIX</i> RTR operating system initialization specified in field 'd'.
FF1B	=	Application function = DRM phase trigger = essential process FPI timeout.
www	=	<i>UNIX</i> RTR operating system application process utility ID: 0017 — First in-first out (FIFO) driver (FDA). 00C0 — Input/output driver (IODRV). 00C2 — Scan and signal distributor administration (SCSD). 0CC — RTR Data Link Driver for DRM 0117 — Plant measurement database monitor (PLDMON). 0186 — Kernel level overload monitor (KLMON) 0410 — Switch maintenance kernel process (SMKP). 0420 — Communications kernel process (CMKP). 0430 — Message switch kernel process (MSKP). 0455 — Recent Change Kernel Process (RCKP) 0460 — Operational kernel process (OKP). 7ED — Communications Module Processor Kernel Process (CMPKP)
x	=	Failed process sequence state. 0 — Created (booted from disk). 1 — Software initialization. 2 — Hardware initialization. 3 — Communication link initialization. 4 — Enable fault recovery. 5 — Essential jobs operational.

		6 — Fully operational.
		7 — Aborting.
y	=	Process run state.
		0 — Running.
		1 — Step done.
zz	=	Error code:
		21 — Initialization timeout
hh hh hh	=	Hardware status digits. Refer to Figure A2-1 for definition of the digits.

A2.2.7.5 Explanation

AIM prints this PRM to report that it was unable to successfully complete an essential process full process initialization (FPI). The FPI, also known as an S5 initialization, failed because of a timeout.

AIM will select a recovery action based on the severity of the problem, the state of the system, and the extent of previous recovery attempts. If the problem persists (recovery thresholds are exceeded), and AM software checks are allowed, AIM will trigger a high-level AM initialization. Otherwise, no initialization will occur. However, the system may not support essential functionality (such as call processing, maintenance, or input/output).

A2.2.7.6 Corrective Action

If several minutes elapse without recovery or escalation to higher levels of initialization, see “Analyze AM Initialization Failure,” 235-105-250, *5ESS Switch System Recovery Manual*.

A2.2.8 PRM:VE FF1F-B

A2.2.8.1 PRM Format

PRM_p vEda FF1F www xyzz hh hh hh

A2.2.8.2 PRM Source

Application Integrity Monitor (AIM) Phase Trigger.

A2.2.8.3 Function

UNIX RTR operating system application process Full Process Initialization (FPI) request.

A2.2.8.4 PRM Expansion

p	=	Active control unit (CU): 0 — CU 0 1 — CU 1
v	=	E - Administrative Module (AM) software checks are inhibited (see "Explanation," Section A2.2.8.5). F - AM software checks allowed. A high level AM initialization will follow immediately.
E	=	Application software generated this PRM.
d	=	Level of most recent <i>UNIX</i> RTR operating system initialization: 0 — No initialization or D0 initialization. 1 — D1 initialization. 2 — D2 initialization. 3 — D3 initialization. 4 — D4 initialization. These initializations are explained in 235-105-250, 5ESS <i>Switch System Recovery Manual</i> .
a	=	Application initialization level within the <i>UNIX</i> RTR operating system initialization specified in field 'd'.
FF1B	=	Application function = DRM phase trigger = FPI request.
www	=	<i>UNIX</i> RTR operating system application process utility ID: 0017 — First in-first out (FIFO) driver (FDA). 00C0 — Input/output driver (IODRV). 00C2 — Scan and signal distributor administration (SCSD). 0CC — RTR Data Link Driver for DRM 0117 — Plant measurement database monitor (PLDMON). 0186 — Kernel level overload monitor (KLMON) 0188 — <i>UNIX</i> RTR operating system supervisor overload monitor process (SUOVPRC). 0406 — Process to load ODD onto Disk (PLOD). 0407 — Application data link (APDL). 0410 — Switch maintenance kernel process (SMKP). 0411 — Switch maintenance power switch monitor (SMPSM). 0420 — Communications kernel process (CMKP). 0430 — Message switch kernel process (MSKP). 0450 — Pump Control (PUCR) 0451 — Automatic Message Accounting Disk Writer (AMDW). 0460 — Operational kernel process (OKP). 0590 — Process for loading ODD into PAS (PLOP).

		0710 — Switch Maintenance Diagnostic Input Message Processor (SMDIMP). SMDIMP is also referred to as deferred maintenance administrator and monitor (DMAM).
		7ED — Communications Module Processor Kernel Process (CMPKP)
		07DD — Automatic message accounting disk writer 1 (AMDW1).
		07CE — Automatic message accounting disk writer 2 (AMDW2).
x	=	Failed process sequence state. 0 — Created (booted from disk). 1 — Software initialization. 2 — Hardware initialization. 3 — Communication link initialization. 4 — Enable fault recovery. 5 — Essential jobs operational. 6 — Fully operational. 7 — Aborting.
y	=	Run state. 0 — Running. 1 — Step done.
zz	=	Error code:20 - INcomplete () failure or timeout (s5 or lower). 22 — Manual "INIT:AM,FPI" request was made. See 235-600-700, <i>Input Messages Manual</i> . 23 — Process Manager (PMGR) death of child message received. 24 — FPI retry requested on process that failed during Administrative Module (AM) initialization.
hh hh hh	=	Hardware status digits. Refer to Figure A2-1 for definition of the digits.

A2.2.8.5 Explanation

AIM prints this PRM to report a request to perform a Full Process Initialization (FPI) on the specified *UNIX* RTR operating system application process. This level of initialization is also known as an S5 initialization.

If the FPI was not manually requested, AIM may select a more severe recovery action based on the state of the system and the extent of previous recovery attempts. If the number of attempted FPIs exceeds a threshold and AM software checks are allowed, AIM will trigger a high-level AM initialization. Otherwise, no initialization will occur. However, the system may not support essential functionality (such as call processing, maintenance, or input/output).

A2.2.8.6 Corrective Action

If several minutes elapse without recovery or escalation to higher levels of initialization, see “Analyze AM Initialization Failure,” 235-105-250, *5ESS Switch System Recovery Manual*.

Digits = These digits represent the hardware status of the PRM. All digits are active in the transistor/transistor logic (TTL) high state. The layout of these digits is as follows:

BIT	3	2	1	0
	POWER UP (RST)	CENTER CONTROL (CC) UNIT RUN	CC ACTIVE	EAI-ALL SEEMS WELL (ASW)

BIT 3: RST - Indicates that the EAI has gone through a power-up restart. This bit will remain set until being read by the maintenance teletypewriter (MTTY) controller.

BIT 2: RUN - Indicates that the associated administrative module (AM) is executing main store instructions. This bit is defined as the logical AND of NOT stopped (system status register ([SSR] bit 28) and NOT halted (SSR bit 17).

HARDWARE STATUS BITS (1 of 6)

Figure A2-1 — Hardware Status Bits (1 of 6)

BIT 1: ACTIVE - Indicates that the associated administrative module (AM) is on-line (SSR bit 16).

BIT 0: ASW - Indicates that the EAI thinks that all seems well (that is, no internal faults or EAoutput errors have been detected by EAI audit or self-test firmware).

Digit 17 = EAI status digit.
The bits are numbered from right to left as follows:

BIT	3	2	1	0
	NEW PRM	MRF START	PULSE POINT REGISTER BIT 23	PULSE POINT REGISTER BIT 22

BIT 3: PRM - Indicates that a processor recovery message has been received from the administrative module (AM). This bit will remain set until being read by the MTTY controller.

BIT 2: SPR - Indicates that a processor recovery maintenance reset function (MRF) has started. This bit will remain set until being read by the MTTY controller.

HARDWARE STATUS BITS (2 of 6)

Figure A2-1 — Hardware Status Bits (2 of 6)

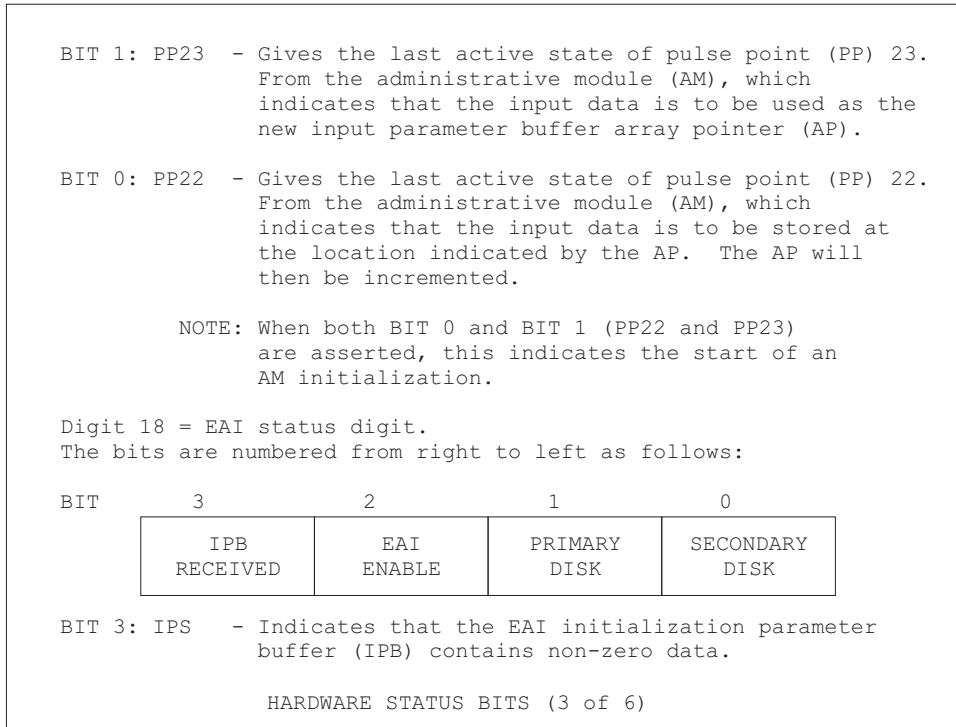

Figure A2-1 — Hardware Status Bits (3 of 6)

BIT 2: EAEN - Indicates a force function to the AM is active or the IPB is non-zero.

BIT 1: FBDP - Indicates that a subsequent system bootstrap will be forced from the primary boot device.

BIT 0: FBDS - Indicates that a subsequent system bootstrap will be forced from the secondary boot device.

Digit 19 = EAI status digit.
The bits are numbered from right to left as follows:

BIT	3	2	1	0
	CC FORCED ON-LINE	CC FORCED OFF-LINE	TIMER DISABLED	CC MRF

BIT 3: FONL - Indicates the AM central control (CC) associated with the EAI is to remain the on-line CC. The mate CC will concurrently be forced off-line (FOFL).

BIT 2: FOFL - Indicates the AM CC associated with the EAI is to remain the off-line CC. The mate CC will concurrently be forced on-line (FONL).

HARDWARE STATUS BITS (4 of 6)

Figure A2-1 — Hardware Status Bits (4 of 6)

BIT 1: DTIM - Indicates the associated AM CC sanity timer is disabled.

BIT 0: MRF - Indicates that a processor recovery maintenance reset function (MRF) has started. This bit is similar to the MRF START bit except that it is tied to the hardware signal (it does not need to be read to be cleared).

Digit 20 = Current status of inhibits.
The bits are numbered from right to left as follows:

BIT	3	2	1	0
	HARDWARE CHECKS INHIBITED	UNIX SYSTEM ERROR INTERRUPTS INHIBITED	CACHE BYPASSED (NOT USED)	SIM INHIBITED

BIT 3: Indicates the AM's automatic hardware checks have been inhibited. The specific checks inhibited are: parity checking (on the Address Translation Bus, Instruction Bus, Source Bus, Micro-Controller, Cache), clock checking errors, My Store Error A, Main Store timeout error, Data Manipulation Unit error, and Store Address Controller error.

BIT 2: Indicates that reporting of non-fatal errors has been inhibited for all units.

HARDWARE STATUS BITS (5 of 6)

Figure A2-1 — Hardware Status Bits (5 of 6)

BIT 1: The AM's high speed cache unit is not being used.

BIT 0: Indicates the System Integrity Monitor process (SIM) has been prevented from initiating any action to recover from a fault.

Digit 21 = Configuration control options.
The bits are numbered from right to left as follows:

BIT	3	2	1	0
	BACKUP FILE SYSTEM BEING USED	MINIMUM CONFIGURATION BEING USED	UNUSED	UNUSED

BIT 3: Indicates the AM has been booted using the backup root file system.

BIT 2: Indicates the AM has been booted in the minimum configuration mode. Application software and hardware has been disabled.

BIT 1: UNUSED (Also undefined - may be 0 or 1).

BIT 0: UNUSED (Also undefined - may be 0 or 1).

HARDWARE STATUS BITS (6 of 6)

Figure A2-1 — Hardware Status Bits (6 of 6)

A3. ADMINISTRATIVE WORKSTATION (AW) SERIAL ASYNCHRONOUS INTERFACE (SunSAI/P) BOARD GROWTH

A3.1 Introduction

The purpose of this appendix is to outline the steps necessary to install and configure the second Serial Asynchronous Interface (SunSAI/P) board into a DRM Administrative Workstation (AW). The second SunSAI/P board would be used for those offices that require more than 6 asynchronous TTY ports.

A3.2 Procedure Overview

The first part of this procedure deals with the *preconditions* necessary prior to execution. The second part of this procedure deals with the *AW preparation* necessary for the SunSAI/P growth. The third part of this procedure deals with installation of the new SunSAI/P hardware. The fourth part of this procedure deals with diagnosis of the new SunSAI/P hardware.

The following outlines the general steps executed in this procedure.

1. Meet the required preconditions.
2. Prepare the Administrative Workstation (AW).
 - Backup the Administrative Workstation (AW).
 - Restore all Moving Head Disks (MHDs).
 - Write the Automatic Message Accounting (AMA) data from memory to disk.
 - Isolate the switching module.
 - Transfer the AMA data from the disk to the output medium.
3. Install serial asynchronous interface board hardware.
 - Halt the AW.
 - Remove power to all AW hardware units.
 - Detach all cables and label them if necessary.
 - Add secondary PCI card to PCI Slot 1.
 - Restore power to all hardware units.
4. Diagnose the new serial asynchronous interface board hardware.
 - Switch to the *UNIX*¹ console of the AW.
 - Login as root.
 - Diagnose the new SunSAI/P.
 - Switch over to the MCC page of the AW.

A3.2.1 Preconditions

The following **preconditions** must be met before executing this procedure.

1. Approximate Execution Time: **1.5 – 2 Hours**

1. Registered trademark in the United States and other countries, licensed exclusively through X/Open Company, Limited

2. Current Software Release: **5E14 or later.**
3. Administrative Workstation: **Fully Operational**
4. Complete set of **Generic Backup** tapes for the following:
 - AM Text
 - AM ODD
 - SM Text
 - SM ODD
 - Emulator and Sun OS
5. One additional Serial Asynchronous Interface Board PCI card (ED5D764-35 Group 15 #X1156A)
6. One additional EIA-232 Connector Box (ED5D764-35 Group 15 #X1156A)
7. One additional EIA-232 Cable (ED5D764-35 Group 15 #X1156A)
8. Anti-static wrist strap
9. Phillips screwdriver
10. The root password for the AW which can be obtained from the *5ESS*[®] Technical Support Services (TSS) organization
11. Reference Documentation: 235-200-150, *5ESS Switch Distinctive Remote Module (DRM) User's Guide*
12. *Sun*² Microsystems Reference Documentation: **Netra³ t 1120/1125 Service Manual**
13. *Sun* Microsystems Reference Documentation: **SunSAI/P User's Guide**
14. *Sun*Microsystems Reference Documentation: **Netra T4 AC100/DC100 Service and System Reference Manual**

A3.2.2 Administrative Workstation (AW) Preparation

1. Backup the AW, refer to "Backup Administrative Workstation Operating System," Procedure 4.4.
2. Restore all Moving Head Disks (MHD).

Note: It takes about 20 minutes to restore an MHD.

 - a. Go to the **AM, AM Peripherals page** by typing and entering command **111**.
 - b. Are any of the MHDs out of service (OOS)? If **YES**, continue. If **NO**, go to **step 3** of "Administrative Workstation (AW) Preparation," Section A3.2.2.
 - c. Enter the appropriate pokes to restore all OOS MHDs. Type and enter command **30X**.

Where: X = MHD number that is OOS.

Response: **RST MHD x IN PROGRESS**

2. Registered trademark of Sun Microsystems, Inc.
3. Trademark of Sun Microsystems, Inc.

- d. Wait until all MHDs are fully restored to the ACT state.
Response: **RST MHD x COMPLETED**
Note: If any MHD cannot be restored, **seek technical assistance.**
3. Write the AMA data from memory to disk.
 - a. Enter the following input command:
WRT:AMADATA
Response: WRT AMA DATA HAS BEEN WRITTEN TO DISK
READY TO TRANSFER DATA FROM DISK TO/OUTPUT MEDIUM
4. Isolate the switching module from the AW.
 - a. Go to the **Switching Module Inhibit and Recovery Control Page** . Type and enter command **1800**.
 - b. Set switching module manual isolation. Type and enter **403**.
Response: **ISOLATE? (Y/N)**
 - c. Type and enter **Y** to the confirmation.
Response: **SET ISOL SM=x COMPLETED**
Where: **x** = The switching module number.
 - d. If the switching module cannot be isolated, **seek technical assistance.**
5. Transfer the AMA data from the disk to the output medium, see 235-105-210, *Routine Operations and Maintenance Procedures*.

A3.2.3 Serial Asynchronous Interface Board Hardware Installation (Netra t 1120)

1. Halt the AW, refer to "Halt the Administrative Workstation," Procedure 4.2.
2. Remove power to the system unit by locating the power switch and switching it to **off**.
3. Detach all cables from the AW System Unit paying particular attention where each cable attaches. If necessary, label each cable and where it attaches to the back of the AW System Unit.

Note: The following procedures require the use of the **Sun Microsystems SunSAI/P User's Guide** and the **Sun Microsystems Netra t 1120/1125 Service Manual**.

4. Add secondary PCI card to PCI Slot 1.

Note: Use the **Installing SunSAI/P Boards** procedures in the **Sun Microsystems SunSAI/P User's Guide** for reference during this step.

Execute the following steps of the sub-procedure **To Replace a PCI Card** in the **Sun Microsystems Netra t 1120/1125 Service Manual**

- Attach a wrist strap
- Remove the top access cover (see "Replace a DAT or CD-ROM/DVD Drive (Netra t 1120)", Section 4.11 Step **3** and **4** of this document).
- Identifying the PCI Slot 1.
- Lower the PCI card so that it touches its associated slot on the motherboard.

- From the two upper corners of the card, push the card straight downwards into the slot until it is fully seated.
 - Using a No.2 Phillips-headed screwdriver, insert and tighten the screw securing the card bracket tab to the system chassis.
 - Replace the top access cover.
5. Reattach all existing cables.
 6. Attach the **new** EIA-232 cable to the **new** PCI card installed in PCI slot 1
 7. Attach the **new** EIA-232 Connector box to the cable attached to PCI slot 1.
 8. Restore power to the system unit by locating the power switch and switching it to **on**.

A3.2.4 Serial Asynchronous Interface Board Hardware Installation (*Netra 20*)

1. Halt the AW, refer to “Halt the Administrative Workstation,” Procedure 4.2.
2. Remove power to the system unit by locating the power switch and switching it to **off**.
3. Detach all cables from the AW System Unit paying particular attention where each cable attaches. If necessary, label each cable and where it attaches to the back of the AW System Unit.
4. Add secondary PCI card to PCI Slot 1.

Note: Use the **Installing SunSAI/P Boards** procedures in the **Sun Microsystems SunSAI/P User’s Guide** for reference during this step.

Execute the following steps of the sub-procedure **To Replace a PCI Card** in the **Sun Microsystems NetraT4 AC100/DC100 Service and System Reference Manual**

- Attach a wrist strap
 - Remove the top access cover (see “Replace a DAT or DVD Drive (*Netra TM 20*)”, Section 4.12 , Step **3** and **4** of this document).
 - Identifying the PCI Slot 1.
 - Lower the PCI card so that it touches its associated slot on the motherboard.
 - From the two upper corners of the card, push the card straight downwards into the slot until it is fully seated.
 - Using a No.2 Phillips-headed screwdriver, insert and tighten the screw securing the card bracket tab to the system chassis.
 - Replace the top access cover.
5. Reattach all existing cables.
 6. Attach the **new** EIA-232 cable to the **new** PCI card installed in PCI slot 1
 7. Attach the **new** EIA-232 Connector box to the cable attached to PCI slot 1.
 8. Restore power to the AW units according to the procedures found in “Restore Power to Administrative Workstation Units,” Procedure 4.8.

When the AW starts to boot, messages similar to those shown in the following examples are output on the system console:

For Netra t 1120

```
Resetting ...
screen not found.
Can't open input device.
Keyboard not present. Using ttya for input and output.
```

```
Sun Ultra 60 UPA/PCI (UltraSPARC-II 440 MHz), No keyboard
OpenBoot 3.29, 512 MB memory installed, Serial #13079967
Ethernet address 8:0:20:c7:95:9f, Host ID: 80c7959f.
```

```
Initializing Memory
Rebooting with command:
Boot device: /pci@1f,40000/scsi@3/disk@5,0:f File and args:
SunOS Release 5.8 Version Generic-108528-13 64-bit
Copyright 1983-2001 Sun Microsystems, Inc. All rights reserved.
```

```
.
.
The system is ready.
attaws console login:
```

For Netra

```
Resetting ...
```

```
Sun Netra T4 (UltraSPARC-III+), No keyboard
Copyright 1998-2002 Sun Microsystems, Inc. All rights reserved.
OpenBoot 4.5, 512 MB memory installed, Serial #51344136.
Ethernet address 0:3:ba:f:73:8, Host ID: 830f7308.
```

```
Initializing Memory
Rebooting with command:
Boot device: /pci@8,700000/scsi@6/disk@6,0:f File and args:
SunOS Release 5.8 Version Generic-108528-13 64-bit
Copyright 1983-2001 Sun Microsystems, Inc. All rights reserved.
```

```
.
.
The system is ready.
attaws console login:
```

The AW will boot and automatically start the AM emulator.

9. Immediately halt the AM emulator using the procedurs outlined in “Halt the Administrative Module (AM) Emulator,” Procedure 4.1.

A3.2.5 Diagnose New Serial Asynchronous Interface Board Hardware

1. Switch to the *UNIX*, console of the AW by holding down the Ctrl key and pressing **Enter** (not Return) on the **MCC**.
2. If a login prompt does not appear, press **Return** repeatedly until one appears.
3. At the console prompt, login as **root**, for example:

```
attaws console login: root
```

```
password: Can be obtained from 5ESS switch TSS.
```

4. Execute the *Sun* Microsystems diagnostic of the newly installed SAI card. At the **#** prompt, enter the following command. The response should be as shown here. The diagnostic test takes approximately 15 seconds to complete.

```
/opt/SUNWvts/bin/saiptest -v -f -o dev=saip1,M=Internal,sp=b
```

Response:

```
"saiptest: Started."  
.3 97/01/30 SMI"  
"Baud rate = 9600, character size = 8, stop bit = 1,  
parity = none, control flow = rtscts"  
"data pattern = 0xaaaaaaaa"  
"Internal Test"  
"Testing device /dev/sad/saip1"  
"Testing device /dev/term/b000"  
"Testing device /dev/term/b001"  
"Testing device /dev/term/b002"  
"Testing device /dev/term/b003"  
"Testing device /dev/term/b004"  
"Testing device /dev/term/b005"  
"Testing device /dev/term/b006"  
"Testing device /dev/term/b007"  
"End saiptest test"  
"saiptest: Stopped successfully"
```

5. Did all of the Sun SAI/P diagnostics complete successfully?

If **YES**, continue with next **step**.

If **NO**, seek technical assistance.

6. Switch over to the MCC page of the AW by holding down the Ctrl key and pressing **Enter** (not Return) on the MCC. Wait for the **MCC** display to appear.

STOP. YOU HAVE COMPLETED THIS PROCEDURE.

A4. DRM SWITCH TO *5ESS*[®] SWITCH CONVERSION PROCESS GUIDELINES

A4.1 Overview

To schedule a conversion of a DRM to a *5ESS* switch contact Lucent Worldwide Services and request the current preconditions that must be met before performing a conversion.

A5. 5ESS Switch DRM Administrative Workstation *NETRA*¹ t 1120 to *NETRA* 20 WITH SOLARIS 8 OS CONVERSION PROCESS GUIDELINES

A5.1 Introduction

This document describes the procedure to convert the *NETRA* t 1120 Administrative Workstation (AW) in a DRM office to the *Netra* 20 AW.

A5.2 Introductions

This procedure will not require any switch downtime or loss of call processing. The SM will be in isolation from the AW for about two hours. This procedure should only be executed on DRM switches running the 5ESS® release [5E16.2 or later]

Note: This conversion procedure will only apply to DRM offices on the 5ESS Switch Generic Releases of 5E16.2 or later. Releases prior to 5E16.2 are not qualified to run on the *Netra* 20.

A5.3 Documentation References

The following is a list of documents to reference during the conversion process:

- “5ESS®-2000 Switch Routine Operations and Maintenance Procedures, 235-105-210”
- “Administrative Workstation for 5ESS-2000 Switching System, ED5D764-30”
- “*Netra* T4 AC100/DC100 Installation and User’s Guide”

A5.4 UNIX² RTR AW INSTALLATION PREREQUISITES

The following hardware and software should be available:

- *Netra* 20 workstation, frame-mounting hardware (if NEBS compliant). The *Netra* 20 is expected to include:
 - At least one internal SAI/P PCI Bus Adapter card with an EIA-232 Serial Interface Cable/Eight-Port Connector Box. In some offices, a second SAI/P may be equipped.
 - One internal HSI/P PCI Bus Adapter card with a "Hydra Style" Serial Port Cable
 - Two internal 36GB disk drives
 - One internal DAT drive
 - One internal DVD drive
 - The *Netra* 20 should be connected to a DC power source. Since the *Netra* 20 actually uses duplex (dual bussed) DC power, new power cables should be used

Assemble the power cables as defined in section 3, subsection "DC Power Supply/Power and Grounding Connections" from the Sun Microsystems *Netra* T4 AC100/DC100 Installation and User’s Guide that was provided with the *Netra* 20.

1. Trademark of Sun Microsystems, Inc.
2. Registered trademark of The Open Group in the United States and other countries.

The Wago connectors, Strain relief housings, and Cage clamp-operating lever are all included with the *Netra 20* that is shipped.

Note: The *Netra 20* uses duplexed power originating on two busses and should be connected to the "A" and "B" busses to provide true duplexed power sources.

Note: The *Netra 20* uses 15A fuses as opposed to the 7A fuses the *Netra t 1120* uses.

Connect the new power cables to the power distribution following local practices.

- All cabling required for the Ethernet connection to the SM.
- All cabling required for the CPI link connections to the SM.
- 120M or greater DAT tapes (to be used for backups/data transfer)
- Obtain the root password for the *Netra 20* workstation from the local 5ESS CTS organization.
- The most recent CD is required:
"3B21 Emulator and SUN OS," Solaris 8 version, for the current release
- Note:** Verify with 5ESS CTS that you have the latest CD-ROM.
- The following DAT tapes are recommended in case of disk corruption:
 - Complete set of tapes to dead start the office in case of disk corruption. These will include Generic Backup tapes for the following (may be multi-volume backup tape):
 - TOP tape
 - AM Text
 - AM ODD
 - SM Text
 - SM ODD
 - Emulator and Sun OS backup (this tape is used to preserve any changes to the emulator or Sun OS software applied since office bring up on this release.)
 - A blank DAT tape that will be used to transfer the 5ESS Generic and data from the *Netra t 1120* to the *Netra 20*.

A5.5 Conversion Procedure

It is imperative that the original system be left in a state that is as functional as possible in case a backout is required. In order to back out of this procedure at any point, return all cables that were moved back to the original system if it was functional and reboot that system.

If office is stable enough to run the full office backup procedure, execute Step A5.5.1 to create a Full Backup of Office. If the office is not stable enough, go to Step A5.8.

A5.5.1 Full Backup of Office

1. Execute procedure 6.17 from the 235-105-210 *Switch Routine Operations and Maintenance Procedures*
2. It is recommended that a full set of office backup tapes be created just prior to the conversion. These may consist of one multi-volume backup tape for some releases. Refer to the 235-105-210, *5ESS@-2000 Switch Routine Operations and Maintenance Procedures*, "Make Full Office Backup Tape", Section 6.23. Automated System Backup can also be used by following Section 6.41, "Schedule Backup To Tape Using Automated System Backup Feature."

These tapes are only needed in the case that both *Netra 20* disks would become corrupted, and it would become necessary to fall back to the *Netra t 1120* workstation. To deadstart an office from tape: refer to the DRM User's Guide, Chapter 7, "System Recovery."

3. Be sure to include a backup of the Operating System and Emulator to tape. For the procedure to create a backup tape. Refer to the DRM User's Guide, Section 4.4, "Back Up Administrative Workstation Operating System."

A5.5.2 Restore MHDs on AW

1. At the AM, AM Peripherals page, type and enter command 111.
2. Are any of the MHDs Out Of Service (OOS)?
If **YES**, continue.
If **NO**, no further action is required.
3. Enter the appropriate pokes to restore all OOS MHDs. Type and enter command 30X:

Where: X = MHD number that is OOS.

Response: **RST MHD x IN PROGRESS**

Where: X = is the first MHD restoral requested; the other will be restored when the first is completed.

A5.6 Write the AMA data, Isolate the SM, and Halt the Emulator

In preparation to powering down *Netra t 1120* workstation, the SM should be placed in isolation. AMA Data should also be written and the Emulator halted.

To do this, execute procedure 4.1, "Halt the Administrative Module (AM) Emulator" from the DRM User's Guide.

A5.7 Copy MHD Images and Configuration Files

1. Switch to the Sun console side of the MCC terminal. Log in as root. The root password should have been obtained from the local 5ESS CTS organization.
2. Insert a blank tape *Netra t 1120* Tape Drive.
3. This step will copy the MHDs (MHD 0 and MHD 2) with the office data and 5ESS Generic from the *Netra t 1120* to tape.

Note: Please type carefully and check the input before hitting enter for the "dd" commands. The character 'n' as the last character in the Output File tape device name of the first "dd" command specifies a non-rewinding tape write. The second "dd" command will cause the tape to rewind. These commands will each

take up to 30 minutes. Wait until the first command is completed before entering the second command.

Execute the following commands:

```
/bin/dd if=/dev/rdisk/c0t0d0s7 of=/dev/rmt/0hn bs=131072
```

```
/bin/dd if=/dev/rdisk/c0t0d0s5 of=/dev/rmt/0h bs=131072
```

After each command completes make a note of how many records were transferred. This information will be used later to verify that a copy of the data into the *Netra 20* partitions completed successfully.

XXXX + xxxx records in

YYYY + yyyy records out

4. Remove the DAT tape from the drive and label the tape with "5ESS Generic Release".

Note: The above two UNIX commands copy MHD 0 and MHD 2 respectively to tape. This tape will be used in a later procedure to initialize the *Netra 20* with the 5ESS Generic and data.

5. Several system files need to be preserved across the conversion and should be written to a new DAT tape. To copy these files off, insert a blank tape in the *Netra t 1120* tape drive and execute:

```
/bin/ls /etc/inet/hosts /etc/inet/netmasks /etc/hostname.qfe0  
/etc/defaultrouter /etc/passwd /etc/shadow /etc/nodename |  
/bin/cpio -ocv > /dev/rmt/0h
```

Remove the DAT tape from the drive and label the tape with "5ESS DRM Network Config Files."

6. Execute the command and record the IP address (###.###.###.###) of the LAST entry. The IP address will be needed in Section A5.14.

```
grep 'connection' /opt/ATT3bem/var/log.emu11
```

7. Exit from the root login by typing "exit" at the command prompt. The "login:" prompt will appear.

A5.8 Shut Down *Netra t 1120* AW

The *Netra t 1120* workstation will now be powered down.

1. Before removing power from the *Netra t 1120*, the system needs to be halted. Refer to Procedure 4.2, "Halt the Administrative Workstation", then remove power to the system unit by locating the power switch and switching it to off.
2. Remove power from all terminals connected to the *Netra t 1120*. Locate the power switches and set them to "Off".

A5.9 Remove *Netra t 1120* from Frame

The *Netra t 1120* needs to be removed from the frame to make room for the new *Netra 20*. Refer to Figures 2-25, "MCC Interface to AW (*Netra t 1120*)", 2-41, "STLWS and ROP Interface(*Netra t 1120*)", and 2-44, "SCANS/AMA/SCCS/Optional OSS Interface (*Netra t 1120*)" for more information unless otherwise noted.

1. Disconnect the serial cables of the MCC terminal from the rear of the *Netra t 1120* workstation (connections at A and B DB-25 Serial Connectors) and label cables "Serial A" and "Serial B".
2. Disconnect the SM Ethernet cable from the *Netra t 1120* RJ45 Twisted Pair Ethernet (tpe) connector (hme0).
3. Disconnect the SAI cable(s) from the *Netra t 1120* workstation PCI slots 1 and 2. If there are two SAI cards equipped on the *Netra t 1120*, take care to label the devices properly to the corresponding primary and optional connector on *Netra 20* workstation.
4. Disconnect the HSI connector from the *Netra t 1120* PCI slot 3.
5. Power off and disconnect the ROP connection from the DB-25 parallel connector on the *Netra t 1120*.
6. Disconnect and remove the DC power cables from the *Netra t 1120*. Also, update the fuse panel label to reflect the available slot.
7. Unbolt the slide rails from the front of the frame and slide the *Netra t 1120* on the chassis slides to the front of the frame. Be careful as the *Netra t 1120* is quite heavy.

A5.10 Mounting New Frame Mounted *Netra 20*

The *Netra 20* needs to be mounted in the frame. Refer to Figures 2-26, "MCC Interface to AW (*Netra 20*)", 2-42, "STLWS and ROP Interface (*Netra 20*)", and 2-45, "SCANS/AMA/SCCS/Optional OSS Interace (*Netra 20*)" for more information unless otherwise noted.

When mounting the *Netra 20*, the chassis slides do not need to be replaced, as they are the same for the *Netra 20* and the *Netra t 1120*.

1. Slide the *Netra 20* on the chassis slides from the front of the frame until fully inserted. Bolt the slide rails to the front of the frame.
2. Connect the serial cables of the MCC terminal to the rear of the *Netra 20* workstation (connections at A and B DB-25 Serial Connectors).
3. Connect the SM from the Ethernet cable to the *Netra 20* RJ45 Twisted Pair Ethernet (TPE) connectors (eri0).
4. Connect the SAI cable(s) to the *Netra 20* workstation PCI Slots 1 and 2. If there are two SAI cards equipped on the *Netra 20*, take care to connect the devices properly to the corresponding primary and optional connector on *Netra 20* workstation.

Note: The slot numbering on the *Netra 20* goes from right to left while the slot numbering on the *Netra t 1120* goes from left to right.

5. Connect the HSI connector to the *Netra 20* PCI slot 3.

6. Connect the ROP connection to the DB-25 parallel connector on the *Netra 20* and Power up the ROP.
7. Connect the DC power to the *Netra 20*
Continue with step A6.11 "Power Up the *Netra 20*"

A5.11 Power Up the *Netra 20*

Power up the *Netra 20*, but immediately after the banner (on the MCC this will be a line of text that begins with "Sun *Netra T4*") is displayed, return to firmware mode (the "ok" prompt) by entering a break sequence on the MCC keyboard. For example, hold down the Control key and press **F5**.

Note: Note: when you power up the *Netra 20*, if you do not see the boot sequence begin on the screen, you must switch to the Sun console side of the terminal by holding down the Ctrl key and pressing Enter (not Return) on the MCC.

A5.12 Boot *Netra 20* OS from CD-ROM

You will now load the *Netra 20* AW from the CD-ROM: "3B21E Emulator and SUN OS," *Netra* version, for the current release.

Refer to the DRM User's Guide, Section 4.5.8, "Format the primary or Secondary Disk from a Boot CD-ROM (*Netra 20*)."

Please Note the Following:

1. Begin at step 2. Step 1 indicates to "Stop the AW" which has already been completed.
2. Format and load the *Netra 20* primary disk, that is, you must execute Step 5.

A5.13 Restore the 5ESS-2000 MHDs

If the *Netra t 1120* was stable at Step A5.5.1 then, execute Step A5.13.1 otherwise execute Step A5.13.2

A5.13.1 Stable System Restore

1. As soon as the EAI page is initialized on the screen, halt the 3B21 emulator from the Emergency Action Interface (EAI) page by entering the poke 59! and responding "y" to the verify request. You will have to time your input between initializations if the system is rolling in initializations.
2. Insert the "5ESS Generic Release" DAT tape created in A6.7, Step 3 into the *Netra 20* Tape Drive.
3. This step will initialize the primary MHD community (MHD 0 and MHD 2) with the office data and 5ESS Generic from the *Netra t 1120* to tape.

Note: Please type carefully and check the input before hitting enter for the "dd" commands. The character 'n' as the last character in the Input File tape device name of the first "dd" command specifies a non-rewinding tape read. The second "dd" command will cause the tape to rewind. These commands will each take up to 20 minutes. Wait until the first command is completed before entering the second command.

Execute the following commands:

```
/bin/dd if=/dev/rmt/0hn of=/dev/rdisk/c1t0d0s7 bs=131072
```

```
/bin/dd if=/dev/rmt/0h of=/dev/rdisk/c1t0d0s5 bs=131072
```

After each command completes, refer to the record count noted in Section A6.7. Verify that the count of records transferred from the tape with each command in this step is exactly equal to the count of records transferred to the tape in Section A6.7. If the counts differ from the counts previously recorded, seek technical assistance.

XXXX + xxxx records in

YYYY + yyyy records out

4. Remove DAT tape from DAT drive.
5. Insert the "5ESS DRM Network Config Files" DAT tape created in step A6.7, Step 5, into the Netra 20 Tape Drive.
6. To restore the DRM Network Configuration Files, enter the following command;
/bin/cpio -icvdu < /dev/rmt/0h
7. Remove DAT tape from DAT drive.
8. Login in to the Administration ID by typing "awadmin" at the console login prompt.
9. From the Administrative Workstation Main Menu, select "Boot the Workstation". Answer **yes** to the confirmation. If you select a task by mistake, answer **no** to the confirmation.

Response:

```
You have chosen to boot the workstation. If the Emulator is running,
it must be halted before continuing. Refer to the Main Menu item of
Halt the Emulator.
```

```
Do you want to continue? (yes/no) yes
```

10. Wait for the boot sequence to complete and then switch back to the MCC view by holding down the Ctrl key while pressing Enter.
11. Continue with Section A5.14, "Verify the Netra 20"

A5.13.2 Unstable System Restore

If the Netra t 1120 was not stable at step A5.7, then execute this step

This procedure is done in two steps. The first step is to provision the Network Configuration files and the second step is to recover the 5ESS software and databases.

A5.13.2.1 Configure DRM Network qfe0 Port

Login to the new *Netra 20* as awadmin and select the option for Configure DRM Network qfe0 Port and follow the procedures outlined in Section A5.16

A5.13.2.2 Recover the 5ESS Software

To recover the 5ESS software, load the system following instructions from Section 7.1.3, Load TOP, AM Text, and AM ODD from Multi-Volume Formatted Backup Tapes" from the DRM User's Guide

A5.14 Verify the Netra 20

The following steps are recommended to verify the operation of the new system.

1. Ensure that call processing is operating normally. Perform test calls per local procedures. If any problems are found, **seek technical assistance**.

2. Ensure that the SM is linked to the AM. This can be observed on the 111 page of the MCC. If the link is established, there will be an unbroken line shown connecting the AM box and the text: SMxxx. If there is a box shown breaking the line connecting the AM and SM, seek technical assistance.

Also, verify that cabling between the SM and the AM by executing the command **"RST:MCTSI"** on the standby side. If diagnostics fail on phase **9** seg **2000**, the cables to SAI-1 (PCI slot 1) and SAI-0 (PCI slot 2) may be reversed. Swap the cables and re-execute the diagnostics. If there is any other failure, contact the next level of support.

3. Check the **124** page to verify if the DCI and ASM are in service. If not, execute the following command:

ping ###.###.###.###

This is the IP address which was recorded in A6.7 Step **6**. If the ping fails, contact the next level of support.

4. Ensure that all terminals and printers are operating correctly. Examples of tests on terminals are:

- For each STLWS, verify that 111 page can be displayed.
- For a remote STLWS, verify that system can be accessed and that 111 page can be displayed.
- For the ROP, verify that OP:CLK output prints normally.

If any problems are seen and cannot be resolved by following the recommended procedures in the appropriate DRM User's Guide, seek technical assistance.

5. Ensure the correct operation of the datalink applications for the office.
 - Perform tests of the ability to send AMA billing data over datalinks to the remote receiver according to normal local procedures.
 - Perform a test of the ability to download a file from SCANS.
 - If equipped, test the operation of the TDMS/EADAS processes over the datalinks. Refer to the DRM User's Guide, Section 8.11.7.
 - If SCC/TNM is equipped, ensure that the SCC/TNM connection to the remote monitoring station is working normally.

A5.15 Backup the Operating System and 5ESS-2000 Software

It is recommended that a new set of full office backup tapes be created after the new system is verified. This should include:

- Full Office Backup
- Backup of Sun Operating System and Emulator

Note: A DDS2 (120M) or greater DAT tape is required to write on the *Netra 20*. The *Netra 20* DDS4 DAT drive WILL NOT write to a 90M tape.

To produce a full set of office backup tapes the 5ESS®-2000 Switch Routine Operations and Maintenance Procedures, Section 6.23, "Make Full Office Backup Tape." or Section 6.41 "Schedule Backup To Tape Using Automated System Backup Feature"

235-200-150
May 2003

APPENDIX 5
5ESS Switch DRM Administrative Workstation *NETRA t 1120*
to *NETRA 20* WITH SOLARIS 8 OS CONVERSION PROCESS
GUIDELINES

To produce a full set of office backup tapes the 5ESS®-2000 Switch Routine Operations and Maintenance Procedures, Section 6.23, "Make Full Office Backup Tape." or Section 6.41 "Schedule Backup To Tape Using Automated System Backup Feature"

To produce a Sun Operating System and Emulator backup tape, refer to the DRM User's Guide, Section 4.4, "Backup Administrative Workstation Operating System."

THIS COMPLETES THE *Netra t 1120* TO *Netra 20* CONVERSION PROCEDURE

A5.16 Configure the DRM Network qfe0 Port

A5.16.1 Introduction

Use this procedure to change the DRM AW qfe0 Port configuration and the DRM Network settings on the DRM AW.

This procedure is performed whenever DRM Network configuration settings need to be changed.

A5.16.2 Required Information

Before beginning this procedure, you must have the new DRM Network configuration information, and know which DRM Network parameters are going to be updated.

Note: Changes to the DRM Network Configuration may require coordinated changes on other components of the DRM Network (ASM, DRM Gateway/Router). Failure to make the necessary coordinated changes could result in loss of communication over the DRM Network.

A5.16.3 Procedure

1. Verify the MCC terminal is powered on and is properly connected to the *SUN³* workstation.
2. If an MCC page is displayed, switch to the UNIX ® console of the AW by holding down the Ctrl key and pressing Enter (not Return).
3. At the login prompt, log in as awadmin.
4. From the Administrative Workstation Main Menu, select "Configure DRM Network qfe0 Port".

Response: **Configure DRM Network qfe0 Port Sub-menu**

Warning: These menu items apply to DRM Workstation configuration procedures.

- 1) Configure DRM qfe0 Port Name and IP Address
- 2) Configure ASM Name and IP Address
- 3) Configure DRM Network Number and Subnet Mask
- 4) Configure DRM Gateway/Router IP Address
- 5) Return to the main menu

Select task by number (1-5):

5. From the **Configure DRM Network qfe0 Port Sub-menu**, select the appropriate task to update the DRM Network configuration with the new configuration values.

Response: The user will be prompted to enter the new configuration information, or if the user wants to use the default values for this configuration.

6. After entering the new values, press **Return** to get back to the **Configure DRM Network qfe0 Port Sub-menu**.
7. If performing other tasks from the Configure DRM Network qfe0 Port Sub-menu, repeat steps 5 and 6. If the user has completed all necessary updates, continue with step 8.

3. Registered trademark of Sun Microsystems, Inc.

8. From the **Configure DRM Network qfe0 Port Sub-menu**, select "Return to the main menu".
Note: The user must now reboot the DRM AW before the changes to the DRM Network configuration can take effect.
9. Perform Administrative Workstation Maintenance Procedure 4.1" Halt the Administrative Module (AM) Emulator".
10. Switch to the *UNIX* console of the AW by holding down the Ctrl key and pressing **Enter** (not Return) on the MCC.
11. From the Administrative Workstation Main Menu, select "Boot the Workstation." Answer **yes** to the confirmation. If you select a task by mistake, answer **no** to the confirmation.

Response:

```
You have chosen to boot the workstation. If the Emulator is running,
it must be halted before continuing. Refer to the Main Menu item of
Halt the Emulator.
```

```
Do you want to continue? (yes/no) yes
```

12. Wait for the boot sequence to complete and then switch back to the MCC view by holding down the Ctrl Key and pressing **Enter** (not Return).
13. **STOP. YOU HAVE COMPLETED THIS PROCEDURE**

GLOSSARY

This section provides acronyms, terms, and abbreviations used in this information product.

GLOSSARY

1 Packet Switching System (1PSS)

A high capacity, high-reliability, X.25 packet switch produced by Lucent Technologies.

3B21 Emulator

Software contained in the Administrative Workstation that emulates the operation of the 3B21D computer.

Administrative Workstation

The DRM *Sun*¹ workstation that provides local operations, administration, and switch maintenance.

AMA

Automatic Message Accounting.

AMADNS

Automatic Message Accounting Data Network Service.

AMATPS

Automatic Message Accounting Teleprocessing System.

American Standard Code for Information Interexchange (ASCII)

An 8-bit (seven bits plus parity) code for data transfer adopted by the American Standards Association to achieve compatibility between data devices. It is also called USASCII. There are also other versions.

ANSI²

An organization that develops and distributes standards for a wide range of commercial products.

ASM

Administrative Services Module.

ASU

Alarm Status Unit.

Asynchronous

A form of communications where each transmitted character has self-contained beginning and ending indications, so that individual characters can be transmitted at arbitrary times.

ATPRC

Automated Translation Processing Recent Change.

Basic Rate Interface (BRI)

The ISDN digital services line that combines two B channels and one D channel on a single line. Also called the basic access rate.

1. Registered trademark of Sun Microsystems, Inc.

2. Registered trademark of American National Institute, Inc.

Basic Rate Interface (BRI) Card

The customer's interface to the ISLU2. Three types of BRI cards exist:

- U-Type for 2 wire
- T-Type for 4 wire.

The U and T type cards provide the customer with the 2B+D capabilities. The Z card performs the analog to digital conversion similar to the CODEC function in the Analog Line Unit. These cards are mounted in groups of 32 and can be mixed, or later, interchanged (with appropriate translation updates). The only restriction is that the T card requires four-wire cabling to the distributing frame.

BILLDATS³

Billing and Data System.

Bit

Contraction of Binary Digit. A single symbol, (1 or 0), that when used in groups, represents the numbers, letters, and other symbols of communications. Generally combined in groups of 5, 8, or 16.

BITS

Building Integrated Timing Source.

Bits Per Second (bps)

Sometimes written as B/S or b/s. A measure of the speed with which data communications can move over a line. The prefixes K (for thousand) or M (for millions) are often used to represent higher speeds.

Blocking

A phenomenon in a communications network where one user cannot reach another due to any one, or a combination of, network resource limitations.

Buffer

Part of a communications processor or switch used to store information temporarily.

Byte

A sequence of successive bits (most often a group of eight) handled as a unit in computer manipulation or data transmission.

Call

A complete, 2-way interexchange of information between two or more parties in a network. It will generally consist of a number of sequential messages or transactions passed over communications circuits in each direction.

Call Request

A message from a network addressable entity to the network requesting the establishment of a virtual call between that network addressable entity and another network addressable entity. In the specific case of an X.25 interface, a call request packet is sent from a data terminal equipment to a data circuit terminating equipment. This packet contains a logical channel number, the calling and called data terminating equipment addresses, and (optionally) a user facility indication and call user data.

3. Registered trademark of AT&T Corp.

Capacity	The ultimate limitation of any resource in a network to hold or move information.
Cathode Ray Tube (CRT)	Used in a generic sense to refer to data terminals that display transmitted and received information on a television-like screen.
CCS	Traffic usage measurement equating to 100 call seconds.
CDX	Compact Digital Exchange.
Channel	A single, physical communications medium capable of moving intelligence from one point to another. Specific physical or logical and electrical parameters generally define its capacity. Also see group or link.
CMP	Communication Module Processor.
CNI	Common Node Interface.
Coder/Decoder (CODEC)	The device that turns analog signals into digital signals and vice-versa.
Communications Module 2 (CM2)	The DRM's fully duplicated time multiplexed switch which acts as a distribution hub for calls and control signals.
Concentration	The effect of having more inputs than outputs for a given system.
CORC	Customer Originated Recent Change.
CU	Control Unit.
Customer-Originated Recent Changes (CORC)	A customer-controlled database change caused by a change in the lines, trunks, equipment, and/or features associated with telephone numbers of a particular telephone office.
DAT Tape Drive	Digital Audio magnetic tape format device for permanent storage of information.
Data Circuit Terminating Equipment	The network side of the user/network (DCE) interface. The CCITT recommendation X.25 specifies the interface between data circuit terminating equipment and data terminal equipment.
Data Link	A communication path directly connecting two entities. Also an ensemble of terminal installations and the interconnecting network operating in a particular mode that permits information to be exchanged between terminal installations.
Data Link Protocol	Guarantees error-free communication between two devices by ensuring that sender and receiver agree on initialization, error detection, and recovery procedures.
Dataphone⁴ Digital Service	Service that provides for direct connection of digital sources to a communications medium and, thereby, to each other.

4. Registered trademark of AT&T Corp.

Data Terminal Equipment (DTE)

The user equipment that is joined to a data communication network. It could be anything from a simple terminal to a large computer system. The CCITT recommendation X.25 specifies the interface between data terminal equipment and data circuit terminating equipment.

D Channel

The packet-switched channel on a DSL at 16 Kbps, or an PRI at 64 Kbps that carries signaling messages and packet switched user data.

DCI

Dual Channel Interface.

Delay

As applied to packet switching, the additional time introduced by the network in delivering a packet's worth of data compared to the time the same information would take on a direct line.

DFC

Disk File Controllers.

Digital Line and Trunk Unit 2 (DLTU2)

The DRM's DLTU2 provides the interface to digital trunks and lines such as T1, EDSL, and remote line units.

DIP

Dual Inline Package.

Direct Connect PIDB (DPIDB)

An interface in the ISLU2 that carries user and control messages from the ISLU2 to the PSU2.

Directory Routing

Technique for routing information through a network based on directories (instructions) kept in the memory of each switch.

DRM

Distinctive Remote Module.

DS1

The common terminology for T-carrier that multiplexes 24 channels into a single 1.544 Mbps bit stream.

DSL

Digital Subscriber Line. See Basic Rate Interface.

DSU2

Digital Service Unit 2.

EADAS

Engineering and Administrative Data Acquisition System.

EAI

Emergency Action Interface.

ECD

Equipment Configuration Database.

EIA

The Electronic Industries Association (EIA) is a trade organization that represents a large number of U. S. electronic manufacturers.

Equal Access (EA)

This is a point where inter-LATA customers access the exchange to request connection across the network boundaries. This is sometimes referred to as "Equal Access."

Error Detection

The process of using information added to a data transmission to detect the presence of errors in the received information.

ESS™ Switching System

A generic term for the switching facilities in commercial networks utilizing computer-like processors rather than purely electromechanical switching relays.

Ethernet⁵	A form of contention protocol being commercially deployed by the Xerox Corporation that is used to tie facilities together in local geographic areas.
Extended Digital Subscriber Line (EDSL)	A limited service of the Bell System Fast Select. An information-bearing call request packet for a virtual call. It may be followed by normal virtual call packet transmissions or may be followed by an information-bearing call-clearing packet with no intervening data packet transmissions.
Flow Control	The mechanism which ensures that the transmitting entity does not overrun the receiving entity with more data than it can accept.
FOI	Full Office Initialization.
FRAD	Frame Relay Access Device.
Frame	The unit of information transferred between two link level protocol entities. Also, a set of consecutive time slots in which the position of each time slot can be identified by reference to a frame alignment signal.
Gateway	A node or switch that permits communication between two dissimilar networks.
Group	A number of communications channels handled as a single entity.
Group Interface Data Bus (GIDB)	Connects the BRI cards to Line Group Controllers.
GUI	Graphical User Interface.
Header	The initial part of a data block or packet that provides basic information about the handling of the rest of the block.
Host	The 5ESS [®] switch in the Switching Complex.
Host	An intelligent processor or device connected to a network that satisfies the needs of remote users.
HSI	High-Speed Interface.
Integrated Services Digital Network (ISDN)	An international plan by the ITU-TS to standardize a public communication network to handle circuit switched digital voice, circuit switched data, and packet switched data.
Integrated Services Line Unit 2 (ISLU2)	Terminates T cars, U cards, and Z cards on the DRM.
Intelligent Terminal	A data communications terminal that has sufficient intelligence (processing power) to perform fairly complex interface functions and local formatting and processing.
Interface	The place at which independent systems or devices communicate with each other.
Interface Units	Provide the subscriber interface to the switching module

5. Registered trademark of Xerox Corporation.

International Standards Organization (ISO)

An international body that standardizes goods and services. The ISO works in conjunction with the ITU-TS for standards that impact communications.

I/O Input/Output.

IOP Input/Output Processor.

IP Internet protocol.

ISDN Integrated Services Digital Network.

ISLU2 Integrated Services Line Unit 2.

I Series Recommendations

ITU-TS recommendations on standards for ISDN services, ISDN networks, user-network interfaces, and under work and maintenance principles.

ITU-TS International Telecommunication Union — Telecommunication Standardization Sector (formerly the CCITT).

Kbps Kilobits per second; sometimes written as Cab/s.

Layer A partition of a layered architecture that performs a defined set of functions and presents those functions to the layer above via a defined interface. A layer uses the functions of the set of layers beneath it to perform its functions. The term layer is synonymous with the term level.

LED Light Emitting Diode.

LEN Line Equipment Number.

Level See Layer.

Limited Distance Modem

A modem used to extend the range of the RS232 interface from 50 to 4000 feet.

Line Group Controller (LGC)

The Line Group Controller in the ISLU2 is responsible for placing the switched information on the Line Interface Data Bus (LIDB). Each LGC has two LIDBs, one to each Service Group. The LGC can also provide concentration, since only 44 time slots are available for switched information. The group of 32 BRIs or cards is connected to a Line Group Controller (LGC) by a Duplicated Group Interface Data Bus (GIDB). In an ISLU2, you can have a maximum of 16 LGCs equipped with 32 BRIs (512 customer terminations).

Line Interface Data Bus (LIDB)

A 32 time slot bus to connect the Line Group Controller and the Common Data boards in an ISLU2.

Link A physical or electrical connection between two end points; for communications purposes, may consist of one or more channels.

Link Level	The second level of a layered architecture. The purpose of the level is to provide the functional and procedural means to establish, maintaining, and release data links. The level also provides techniques to recover from transmission errors and other abnormal conditions such as invalid or no responses and lost of synchronization.
Local Access and Transmit Area (LATA)	A defined geographical area where equal access end offices and/or access tandem offices can provide carrier access to the local exchange.
Local Area Network (LAN)	A high-volume data transmission facility interconnecting a number of data devices, generally within a building or a campus.
Logical Channel (LC)	A point-to-point data communication path that shares a physical transmission medium via packet interleaved statistical multiplexing. In packet switching, a packet typically contains a logical channel number that identifies the packet with a particular virtual call.
Logical Connection	A communication relationship between two end points that utilizes a virtual circuit connection between the associated Network Addressable Entities (NAEs).
Loop (Local)	Telephone terminology that refers to the local connection between a network switch and the subscribers end instrument.
Loop (Routing)	The undesirable condition in a network where traffic gets routed in a circular path due to an anomaly of the software or address information.
LU	Line Unit.
Main Distributing Frame (MDF)	The interconnect between the outside plant facilities and the C.O. wire.
Mbps	Megabytes per second.
MCC	Master Control Center.
MCTSI	Module Controller/Time Slot Interchanger. A device on the DRM which performs the time switching function.
MDF	Main Distributing Frame.
Messages	The logical unit of information passed between two session level protocol entities. A block of text that the user of a communication network wishes to have transported as a whole. The unit of communication as seen by the user may be segmented into several packets to traverse the network. In some circumstances, several messages can be carried in one packet.
MHD	Moving Head Disk.
MHEIB	Message handler <i>Ethernet</i> Interface Bus.
MMSU	Modular Metallic Service Unit.
Modem	MOdulator-DEModulator. A device that allows digital signals to be transmitted over analog facilities.

MT	Magnetic Tape.
MTTY	Maintenance Teletypewriter.
Multiplexing	See Logical Multiplexing.
Multi-Service Access Device	An access device that provides connectivity between network elements and Network Management systems.
Network	A communication system to interconnect various devices.
Network Address	Coded data that identifies the location of a network addressable entity on a 1PSS.
Network Addressable Entity (NAE)	Any entity directly connected to the network that supports the access interface protocol(s). Every network addressable entity is identified by a network address. These network addressable entities may include such items as user computers, intelligent terminals, host (vendor) computers, Electronic Switching System switching equipment processors, certain network functions, and 1PSS provided virtual terminals.
NM	Network Maintenance.
Node	A point of a network where various links come together; generally containing a switching element used to direct traffic.
OA&M Functions	Operation, Administration, and Maintenance functions.
ODD	Office Dependent Data.
OS	Operation Services.
OS	Operational Support.
OS	Operating System.
Packet	The unit of information passed between two packet level protocol entities. It consists of a group of bits including data and control elements and routing information in a specified format. Also, a block of data handled by a network in a well defined format including a header and having a maximum size of data field. The unit of information passed between levels 2 and 3.
Packet Level	Level 3 of the 1980 CCITT Recommendation X.25 interface specification. It specifies the way control information and user data are structured into packets and the elements of procedure for use of control information.
Packet Switch	The equipment in a node that is responsible for accepting and routing packets and ensuring their correct arrival at an adjacent node.
Packet Switched Data	Data transmitted over a Packet Switched network.
Packet Switched Network (PSN)	The interconnection of two or more packet switches to transfer data.

Packet Switching	A network technique that divides user messages into relatively short blocks and uses geographically distributed switching nodes, to achieve low end-to-end delay for real-time, bursty data traffic.
PC	Personal Computer.
Permanent Virtual Circuit (PVC)	A virtual circuit established for the duration of an agreement between the subscriber and the network authority and is available to send packets in either direction at any time. It has all the features of a virtual call without the call setup and release procedures.
PIDB	A Peripheral Interface Data Bus (PIDB) is an interface in the ISLU2 that provides PSU2 timing and a path to other switching modules and carries circuit switched information from the SG to the TSI (MCTU3).
Protocol	A set of rules for conducting interactions between two or more entities. These rules consist of syntax (for example, header structure), semantics (the actions and reactions that are supposed to occur), and timing (the relative ordering and duration of events and states).
PSTN	Public Service Telephone Network.
PSU2	Packet Switch Unit 2.
PTN	Packet Transport Network.
Random Routing	Routing technique that moves information through the network in a statistically random matter.
Recent Change (RC)	This system function allows maintenance personnel access to the DRM database. Recent change is used to add to or delete from databases and update or verify the database using select/mark format.
Recovery Procedures	A set of actions designed to restore a device to normal operations.
Retrofit	The ability to upgrade a DRM without impairing service to the subscriber.
ROP	Receive-Only Printer.
Routing	The process of finding a suitable path to move information through the network. (See Adaptive Directory Routing, Directory Routing, and Random Routing.)
Routing Table	A set of instructions stored at each switch indicating the path to move a given packet to a given destination.
RS232 (RS232C)	Technical specifications set by the Electronic Industries Association (EIA) which define electrical and mechanical interfaces between terminals, modems, computer, and communications lines.
SAI	Serial Asynchronous Interface.
SCANS	Software Change Administration and Notification System.

SCCS	Switching Control Center System.
Service Group (SG)	An ISLU2 has two Service Groups (SG) that operate active/active to switch information in the Common Data Circuits (2 per SG) to the appropriate paths. These paths are: <ul style="list-style-type: none"> • The LIDBs to the LGCs. • The PIDBs to the TSI (MCTU3). Direct Connect PIDBs (DPIDBs) to the PSU2. The number of PIDBs and DPIDBs is an engineered quantity, while each LGC has two LIDBs.
Service Units	Provide call processing and testing functions within the switching module.
Session	A cooperative relationship between two application entities characterizing the communication of data between them.
SFID	Secure Feature ID.
SLC[®] Carrier System	The <i>SLC</i> carrier system provides duplex data link capability simultaneously with voice usage on the existing subscriber voice loops at data rates up to 4800 bps
SM	Switching Module.
SMPU5	Switching Module Processor Unit Model 5.
SNA	Systems Network Architecture (SNA) is the computer network architecture developed by IBM.
STLWS	Supplementary Trunk Line Workstation.
SU	Software Update.
Switching Module	The DRM switching module provides call-processing intelligence and complete switching for intra-switching-module calls.
Switching Node	A location in a network where switching takes place.
Synchronous	A form of communications where characters or bits are sent in a continuous stream with the beginning of one contiguous with the end of the preceding one. Separation of one from another requires the receiver to maintain synchronism to a master timing signal. Abbreviated Sync.
Synchronous Data Link Control (SDLC)	IBM's version of the ADCCP link control technique. A full-duplex protocol developed by IBM.
Synchronous Time Division Multiplexing (STDM)	The combining of multiple inputs into a single narrow band time divided output by a sampling technique that transmits all inputs including idles.
Systems Network Architecture (SNA)	The computer network architecture developed by IBM.
T1	A digital transmission standard in North America that carries traffic at the DS1 rate of 1.544 Mbps.
TAU	Test Access Unit.
TDMS	Traffic Data Management System.

TE	Terminal Equipment.
Terminal	Any device capable of sending and receiving information over a communication channel. It is used to enter data into a computer system and to communicate the outputs of the system to the affected environment. Terminal devices include computers, teleprinters, special keyboards, light displays, cathode-ray tubes, thermocouples, pressure gauges and other instrumentation, radar units, telephones, etc.
Time Slot	An identifiable increment in the output of a multiplexing scheme.
TMS	Time Multiplexed Switch.
Transaction	A computer-based message that represents a complete unidirectional transfer of information between two points on a data network.
TRFC30	30 Minute Traffic Report.
Trunk	The communications circuit between two network nodes or switches.
TSIU	Time Slot Interchange Unit.
TTYC	Teletypewriter Controller.
VCDX	Very Compact Digital Exchange.
Virtual Call (VC)	A user facility in which a call setup procedure and a call clearing procedure determine a period of communication between two data terminal equipments in which user data is transferred in the network in the packet mode of operation. All user data is delivered from the network in the same order in which it is received by the network.
Virtual Circuit	A logical, rather than physical, path for a call. For example, one call's packetized data may be sent over different physical paths through a network to one destination.
Wide Area Network (WAN)	A high-volume data transmission facility interconnecting a number of data devices, generally linking a building or a campus.
Window	The major element of the flow control mechanism used to prevent the overload of a packet network. The window size indicates the number of packets a given user can have outstanding in the network at any given time.
X.25	A ITU-TS recommendation that specifies the interface between data terminal equipment and data circuit terminating equipment for terminals operating in the packet mode on public data networks. This user to network interface includes physical, frame, and packet levels of protocol. Network services provided to the user across the X.25 interface currently include virtual calls and permanent virtual circuits. Proposed revisions would provide the transaction-oriented datagram and fast select features.

- X.75** The X.75 packet switch interface is characterized as a high throughput and a high flexibility interface. It supports virtual call service and the X.75 utilities necessary to provide the essential facilities of X.25 as well as some additional features.
- X.75 Prime** A modification of X.75 by Bellcore to allow the interconnection of dissimilar equipment in the same network.

NUMERICAL

111/112 MCC page, [2-43](#)
[113](#) MCC page, [2-44](#)
116 MCC page, [2-45](#)
1190 MCC page, [2-48](#)
124 MCC page, [2-47](#)
1400 MCC page, [2-50](#)
3B21 emulator, [2-41](#)
3B21D Administrative Module (AM), [2-2](#)
982YD paddle board: replace, [6.6-1](#)

A

Activate/Deactivate balance feature, [5.10-1](#)
Administrative Workstation (AW) maintenance, [4-1](#)
Administrative Workstation: backup operating system, [4.4-1](#)
Administrative Workstation: boot from alternate disk, [4.5-1](#)
Administrative Workstation: call impact, [2-5](#)
Administrative Workstation: DAT tape drive unit, [4-1](#)
Administrative Workstation: functions, [2-61](#)
Administrative Workstation: halt, [4.2-1](#)
Administrative Workstation: interface connections, [2-5](#)
Administrative Workstation: operations, [2-5](#)
Administrative Workstation: Partition and Propagate system to non—active disk, [4.5.6-1](#)
Administrative Workstation: remove power (Netra t 1120 and Netra 20), [4.7-1](#)
Administrative Workstation: replace defective hardware (*Netra t 1120*), [4.5.1-1](#)
Administrative Workstation: restore, [4.3-1](#)
Administrative Workstation: restore power (Netra t 1120 and Netra 20), [4.8-1](#)
Administrative Workstation: storing AMA data, [2-5](#)
Alarm Status Unit (ASU), [2-13](#)
Alarms: allow, [2-50](#)
Alarms: building power, [2-50](#)
Alarms: inhibit, [2-50](#)
Alarms: retire, [2-50](#)
All Seems Well (ASW), [2-39](#)
AM emulator: halting, [4.1-1](#)
AM initializations, [A2-1](#)
AM ODD tape, [4-1](#)
AM Text tape, [4-1](#)
AMA data link growth, [8.8-1](#)
AMADNS, [2-62](#)
Architecture: DRM, [2-2](#)
Assistance, Technical, [1-4](#)
Audible ring, [2-12](#)
Automatic circuit pack Return Tag (RTAG) tool, [6.4-1](#)
Automatic Message Accounting (AMA), [2-62](#)
Automatic Message Accounting (AMA): data link, [2-45](#)
Automatic Message Accounting (AMA): direct network system, [2-45](#)
Automatic Message Accounting (AMA): teleprocessing system, [2-45](#)
AW: remove DVD drive, [4.12-1](#)

AW: replace CD-ROM/DVD drive, [4.11-1](#)
AW (*Netra t 1120*): replace DAT, [4.11-1](#)
AW (*Netra20*): remove DAT, [4.12-1](#)

B

Back Up The *DynaStar 500* (Base/Growth) Router Configuration File at the Host Site, [3.4-1](#)
Backout last official Software Updates (SUs), [5.6-1](#)
Backout operating system Software Update (SU), [5.8-1](#)
Backout Software Update (SU), [5.7-1](#)
Backup AW operating system, [4.4-1](#)
Balance feature: activate/deactivate, [5.10-1](#)
Basic rate interface, [2-16](#)
BITS Clock, Stratum 3 Convert, [5.11-1](#)
Boot AW from alternate disk, [4.5-1](#)
BRI, [2-16](#)
Building power alarm, [2-50](#)

C

Cajun Switch Software Version Procedure, [3.12-1](#)
Capacities: line and trunk, [2-13](#)
Cathode ray tube, [2-19](#)
CD-ROM/DVD drive: replace, [4.11-1](#)
Centralized Telephone Communications Exchange Service (CENTREX), [2-1](#)
Circuit pack handling, [6-1](#)
Circuit pack handling: static discharges, [6-1](#)
Common Units, [2-10](#)
Communications Module 2 (CM2), [2-2](#)
ConnectVU (ATPRC) data link growth, [8.10-1](#)
Conversion procedure, *Netra t 1120* to *Netra 20* [1-3](#)
Corrective maintenance, [6-1](#)
Courses, training, [1-9](#)
CPI paddle board: replace, [6.7-1](#)

D

DAT: remove, [4.12-1](#)
DAT: replace, [4.11-1](#)
DAT tape drive unit, [4-1](#)
DAT Tape Drive Unit: emergency tape ejection (*Netra t 1120*, *Netra 20* and *Netra 240*), [4.21-1](#)
DAT tape drive unit: load tape, [4.19-1](#)
DAT tape drive unit: unload tape, [4.20-1](#)
Data entry functions, [2-52](#)
DDS cleaning cartridge, [4.22-1](#)
Dead start recovery, [7.1-1](#)
Dial tone, [2-12](#)
Digital Audio Tape (DAT) tape drive unit, [4-1](#)
Digital Line and Trunk Unit 2 (DLTU2), [2-12](#)
Digital Network Unit - Sonet (DNU-S), [2-12](#)

Digital Service Control (DSC) Unit, 2-12
Digital Service Unit 3 (DSU3), 2-12
Display Administration Process (DAP), 2-56
Distinctive Remote Module (DRM), 2-1
Document Distribution, 1-3
Documentation, 1-9
Documentation: CD-ROM, 2-1
DRM: architecture, 2-2
DRM: features, 2-62
DRM: hardware, 2-3
DRM: line and trunk capacities, 2-13
DRM Network, 2-13
DRM Network Element Software Download Procedure, 3.11-1
DRM: software, 2-60
DRM Switch to 5ESS Switch Conversion Process, 1-3
DRM SWITCH TO 5ESS SWITCH CONVERSION PROCESS GUIDELINES, A4-1
DRM *NETRA* t 1120 to *NETRA* 20 WITH SOLARIS 8 OS CONVERSION PROCESS GUIDELINES, A5-1
DVD drive: remove, 4.12-1
DynaStar Router Software Version Procedure, 3.13-1

E

Emergency Action Interface (EAI), A2-1
Emergency Action Interface (EAI): maintenance commands, 2-43
Emergency Action Interface (EAI): menu, 2-40
Emergency Action Interface (EAI) page, 2-38
Emergency Action Interface (EAI): validating, 2-39
Emulator: halting, 4.1-1
Equipment Configuration Data (ECD), 2-60
Equipment Configuration Database (ECD), 4-1
Equipment Test List (ETL), 5-1
Establish communication with an isolated switching module, 7.3-1
Ethernet Interface Board (EIB), 2-6 2-10

F

Features: DRM, 2-62
Features not supported, 2-67
Format the primary or secondary disk from a boot CD-ROM (*Netra* 20 or *Netra* 240), 4.5.8-1
Format the secondary disk from a boot CD-ROM (*Netra* t 1120), 4.5.7-1

G

Gated Diode Crosspoints Access (GDXACC): unseating, 6.3-1
Global Digital Service Function (GDSF), 2-12
Growth and degrowth, 8-1

H

Halt the Administrative Workstation, [4.2-1](#)
Halt the AM emulator, [4.1-1](#)
Hardware: DRM, [2-3](#)
Head cleaning: DAT tape drive unit, [4.22-1](#)

I

Input/Output, [2-19](#)
Install operating system Software Update (SU), [5.5-1](#)
Integrated Digital Carrier Unit (IDCU), [2-12](#)
Integrated Services Digital Network (ISDN), [2-1](#) [2-3](#)
Integrated Services Test Function (ISTF), [2-12](#)

L

Line Unit 3 (LU3), [2-12](#)
Line Unit Auto Power Recovery (LUAPR), [6.3-1](#)
Line Unit (LU) circuit packs: remove and insert, [6.3-1](#)
LNCS, [2-13](#)
Load Software Update(s) from tape, [5.2-1](#)
Load the 3B21 emulator and operating system CD-ROM and boot the AW, [7.1.1-1](#)
Load TOP, AM text, and AM ODD backup tapes, [7.1.3-1](#)
Locked-up video terminal: restore, [6.1-1](#)
Lucent network component solution, [2-13](#)

M

Make Software Update(s) official, [5.4-1](#)
Manual recovery capabilities, [2-38](#)
Master Control Center (MCC), [2-31](#)
Master Control Center (MCC): cable connections, [2-31](#)
Master Control Center (MCC): display, [2-35](#)
Master Control Center (MCC): function keys, [2-51](#)
Master Control Center (MCC): functions, [2-35](#)
Master Control Center (MCC): index page, [2-36](#)
Master Control Center (MCC) terminal settings, [A1-3](#)
MCC access growth: dial-up modem, [8.5-1](#)
MCC Display: AM, AM peripherals, [2-43](#)
MCC Display: DCI/ASM Status, [2-47](#)
MCC Display: MCTSI Status, [2-48](#)
MCC Display: Miscellaneous Status, [2-45](#)
MCC Display: Operations systems links, [2-44](#)
MCC Display: SM/BLDG/PWR Alarm, [2-50](#)
MCC Function Key: alarm release, [2-52](#)
MCC Function Key: ALM RLS, [2-51](#)
MCC Function Key: CMD/MSG, [2-51](#)
MCC Function Key: EMER DISP, [2-51](#)
MCC Function Key: emergency action display, [2-52](#)
MCC Function Key: input command or message, [2-52](#)
MCC Function Key: NORM DISP, [2-51](#)

MCC Function Key: normal display, 2-52
Modular Metallic Service Unit (MMSU), 2-12
Module Controller/Time Slot Interchange (MCTSI), 2-10
Mount tape on tape drive unit, 4.19-1

O

Office Record Printer baud rate: update, 8.14.1-1
Office Record Printer degrowth, 8.21-1
Office Record Printer growth, 8.14-1
Operating system: backup, 4.4-1
Operational Support Systems (OSSs), 2-19
Operator Services Position System (OSPS), 2-3
Optional terminal interfaces, 2-19

P

Password protection, 2-60
Peripheral Units (PUs), 2-12
Plain Old Telephone Service (POTS), 2-1 2-3
Post AM recovery cleanup, 7.2-1
PRI, 2-16
Primary rate interface, 2-16
PRM, 1-3
PRM - 60XX, A2-5
PRM - CB00, A2-8
PRM - FF03, A2-10
PRM - FF05, A2-11
PRM - FF06, A2-13
PRM - FF1B-B, A2-15
PRM - FF1F-B, A2-17
PRM:EE 5F06, A2-2
Processor recovery messages, 1-3
Processor Recovery Messages (PRMs), A2-25

R

RC/V terminal degrowth, 8.18-1
RC/V terminal growth, 8.4-1
Receive-Only Printer (ROP), 2-19 2-35 2-53
Recent Change (RC/V) terminal, 2-56
Recorded Announcement Function (RAF), 2-12
Recover from BROOT configuration, 7.2.4-1
Remote Integrated Services Line Unit (RISLU), 2-13
Remote *Sun* Console access growth: dial-up modem, 8.6-1
Replace a Defective Primary Disk (*Netra 20*), 4.5.3-1
Replace a Defective Secondary Disk (*Netra 20*), 4.5.2-1
Retrofit, 2-62
Retrofit: generic, 2-46
Revenue Accounting Office (RAO), 2-45
RMAS data link growth, 8.12-1
Routine maintenance, 5-1

Rural Electrification Administration (REA), 2-1

S

Sanity Timer: disable, 2-38
SCANS data link growth, 8.7-1
SCC data link degrowth, 8.19-1
SCC data link growth, 3.8-1 8.9-1
Signaling System 7 (SS7), 2-62
Software Change Administration and Notification System (SCANS) data link, 2-57
Software: DRM, 2-60
Software release retrofit, 2-62
Software release update, 2-63
Software: switching module, 2-62
Software Updates (SUs), 2-57
Software Updates (SUs): backout, 5.7-1 5.8-1
Software Updates (SUs): backout last, 5.6-1
Software Updates (SUs): install, 5.5-1
Software updates (SUs): load from SCANS, 5.1-1
Software Updates (SUs): load from tape, 5.2-1
Software Updates (SUs): make official, 5.4-1
Static discharges, 6-1
STLWS degrowth, 8.17-1
STLWS growth, 8.3-1
Stratum 3 BITS Clock, Convert, 5.11-1
SUN OS tape, 4-1
Sun Console terminal settings, A1-3
Supplemental Trunk and Line Work Station (STLWS), 2-56
Switching module, 2-2 2-3
Switching module memory errors: analyze and clear non-diagnosable, 6.5-1
Switching Module ODD tape, 4-1
Switching module software, 2-62
Switching Module Text tape, 4-1
System: boot, 2-38
System recovery, 7-1
System recovery: Post AM recovery cleanup, 7.2-1

T

T1/E1 external reference timing, 2-12
TDMS/EADAS data link growth, 8.11-1
Technical Assistance, 1-4
Technical Support Services (TSS), 1-4
Terminal interface devices, 2-21
Terminal software initialization, 6.2-1
Tone decoding, 2-12
Tone generation, 2-12
TOP tape, 4-1
Traffic Printer degrowth, 8.20-1
Traffic Printer growth, 8.13-1
Training courses, 1-9
TSS, 1-4

U

UNIX Operating System, [2-61](#)
UNIX RTR operating system, [A2-2](#)
User Comments, [1-3](#)

V

Video Display Terminal (VDT), [2-35](#)
Video terminal: restore locked-up, [6.1-1](#)
Virtual TTY controller degrowth, [8.15-1](#)
Virtual TTY controller growth, [8.2-1](#)
Virtual TTY degrowth, [8.16-1](#)
Virtual TTY growth, [8.1-1](#)
Voice Path Assurance (VPA), [2-12](#)

