



Ensuring MIMO Device Performance with Over-the-Air Testing

Not All Mobile Devices are Created Equal

The complexity of mobile devices and networks continues to grow with the increasing application of technologies such as MIMO. Ideally, all facets of network performance and user experience that employ this innovation should be tested. Recognizing the importance, operators and manufacturers have worked with the industry to develop a test methodology that fully evaluates baseband modem performance and antenna design for MIMO operation. In view of this and similar development challenges, the CTIA developed a testing standard¹ to determine the Over-the-Air (OTA) performance level of handsets that employ MIMO antennas.

As an investigation into what MIMO device performance variances might be, Signals Research Group conducted a study² that included evaluation of fifteen commercial MIMO mobile devices across two different OTA labs³.

The study results revealed interesting and significant differences in the performance of smartphones that, in the real world, would have a noticeable effect on user experience. This included triple-digit differences in data rates, universal under-performance in at least one frequency band, and a minimal relationship between handset price and reception quality.

In short, this study validated the value-add of OTA testing in evaluating MIMO device performance. Performance issues in the antenna design will translate into a poor Quality of Experience (QoE), including poor reception, slow downloads, and subpar application performance. For operators, poor QoE can cause increased customer churn and additional investment in network infrastructure to compensate for low quality.

1. "Test Plan for 2x2 Downlink MIMO and Transmit Diversity Over-the-Air Performance," CTIA

2. Signals Ahead, "Chips and Salsa XX: When Iconic Meets Anechoic, Part II," October 29, 2015

3. Tests on the same device at different locations had the same results, indicating uniform testing procedures.

Ensuring MIMO Device Performance with Over-the-Air Testing

Introduction

This white paper discusses the need for MIMO testing using Over-the-Air methods and describes the test features defined in CTIA's MIMO OTA Test Plan.

Why OTA?

The overall goal of any sort of handset testing is to ensure a high QoE. However, with MIMO devices, throughput depends on antenna performance in realistic propagation environments, which cannot be simulated accurately with baseband (conducted) testing. This is why OTA testing is essential for MIMO.

OTA testing for Single-Input Single-Output (SISO) allows for the separation of baseband testing and antenna testing, with the exception of a device's internal desense issues. Other than differences in receiver input levels due to antenna performance, modem performance is not coupled to antenna performance in SISO scenarios.

In contrast for MIMO, the codependency exists. The antenna performance not only affects the signal levels presented to the receivers but also the correlation between the two (or more) receivers. MIMO performance is a function of Signal-to-Interference-plus-Noise-Ratio (SINR) and antenna correlation. How the device sees the wireless environment through the antennas can greatly affect modem performance. The modem will have a harder or easier time in decoding the different data streams depending on the environmental conditions. MIMO OTA creates a unique spatial signature to replicate realistic propagation scenarios in a controlled environment for performance testing.

Realistic evaluations of device performance are therefore imperative for MIMO systems. MIMO performance is a function of the wireless channel and the antennas, so testing must combine characteristics such as:

- Antenna gain or efficiency
- Branch imbalance
- Dual polarized channel conditions to replicate the handset environment
- Correlation between antennas

This last point is extremely important. MIMO exploits low correlation of signals to achieve better performance. Correlation depends on the gain for each antenna, the antenna phase response, and the power angle distribution of the signal, which is a function of the wireless channel. Multiple scattered copies of the signal will combine at each antenna. Each plane wave arrives at the first antenna and a moment later it arrives at the second antenna at a slightly different phase. Rayleigh fading occurs at each antenna with a different fading envelope, but it is correlated. The actual amount of correlation is determined by the phase difference between each plane wave.

OTA (radiated) antenna testing is the best existing approximation to real world conditions due to the highly controlled environment specified by the CTIA. This includes the use of an anechoic chamber, which provides the capability of producing spatial channels with the correct field structure in the test volume such that the device under test (DUT) can observe the expected channel during the test.

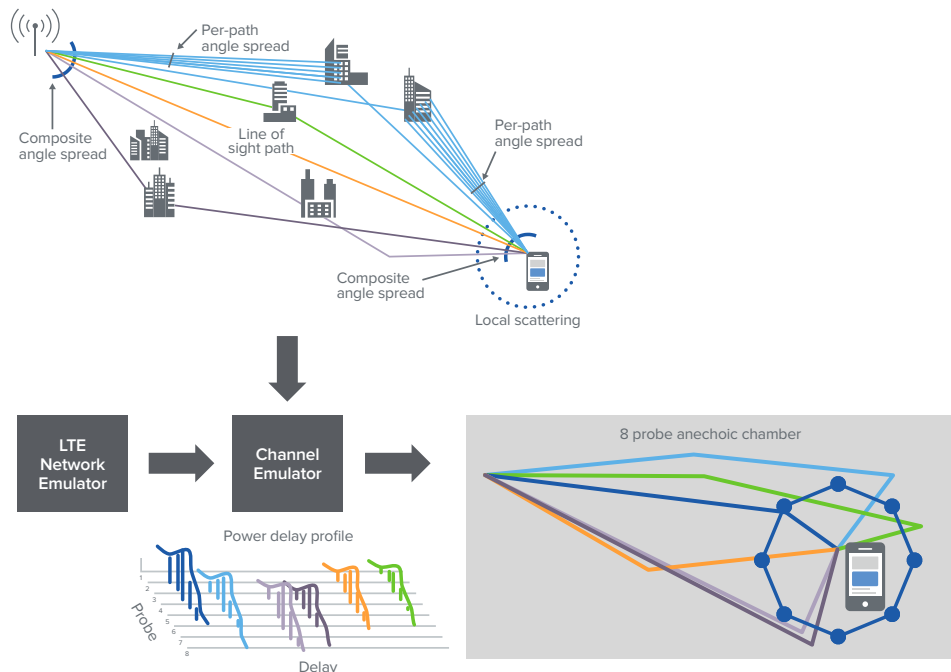

Anechoic chamber working principle.

The reception of signals from different paths and at different arrival times is known as the Power Delay Profile (PDP). The PDP will have corresponding angles of departure and angles of arrival. In most of these types of cluster-based models, the departure angle does not have to be aligned to the arrival angle. Because only the initial and final angles are needed to determine the model, we only need to know the delay and power of each path, not where each reflector might have been. Each path is seen by each device antenna with unique magnitude and phase. One such geometric channel model is the SCME (Spatial Channel Model Extended) model, which is standardized in 3GPP and utilized in CTIA.

As mentioned earlier, an anechoic chamber is utilized to reproduce the correct field structure in the test volume. This is accomplished by mapping the signal levels across the probes in the chamber. A spatial channel emulator provides the following functionality in order to create a realistic propagation environment:

- Base antenna separation
- Angle spread
- Dual polarization
- Channel Cross-polarization Power Ratio (XPR)
- Multi-path components
- Doppler
- Noise/interference

Ensuring MIMO Device Performance with Over-the-Air Testing

CTIA MIMO OTA Test Plan

The CTIA determined the most optimal setup for MIMO OTA testing within its current test plan. The following sections provide an overview of a portion of that MIMO OTA Test Plan.

Test Setup and Validation

MIMO OTA testing is conducted in an anechoic chamber with 8 dual-polarized probes. This configuration is referred to as the Anechoic Chamber Multi-Cluster or the Multi-Probe Anechoic Chamber (MPAC). The CTIA requires various tests [ripple test, range calibration, and Signal-to-Interference Ratio (SIR) validation] to ensure the quality of the chamber setup and that evaluation is conducted at the correct power levels without extraneous signal interference. In addition, definitions of measurement uncertainty elements are provided and an overall measurement uncertainty limit is defined.

CTIA also defines all the channel model validation procedures for key channel model items, which include PDP, Doppler/temporal correlation, and spatial correlation. Finally, cross polarization is examined to check if the signal arrives at the handset in a way which verifies that the amount of signal, in both vertical and horizontal polarization, is in accordance with the expected model. The channel model validation tests are typically performed by the system provider and not the individual labs.

Upon confirming that the setup meets CTIA standards, test execution is performed using 2x2 downlink MIMO open loop spatial multiplexing (Transmission Mode 3, or TM3) for both FDD and TDD technologies. A spatial channel emulator creates the simulated wireless channel environment. In particular, the SCME Urban Macro (UMa) channel is used with a non-directional SIR-controlled environment. This involves providing equal noise levels at each antenna probe while ensuring that the device being tested is not subjected to correlated interference or noise.

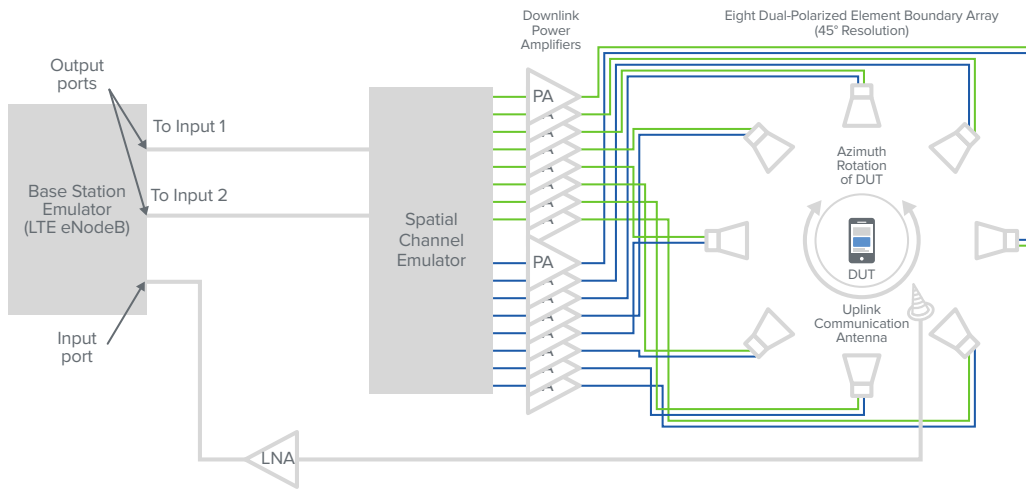

Test setup for anechoic chamber-based OTA testing (specific RF connections are dependent on implementation).

Measurements

Performance is measured using a figure of merit referred to as MIMO Average Radiated SIR Sensitivity (MARSS). Average SIR is used because, for a given throughput, it provides a more representative metric for operators to access a particular device's expected user experience, based on network coverage planning.

Testing examines the average SIR value representing 95%, 90%, and 70% throughput thresholds based on the theoretical maximum for the defined reference measurement channel. Each test uses the average from twelve azimuthal orientations. Throughput performance should be examined in both portrait and landscape positions for the handset. CTIA requires certain operating bands to be tested for CTIA certification. However, the test plan also provides guidelines for additional operating bands so that they can be used by outside certification bodies.

Upon completion of the testing routine, reporting is accomplished using templates provided by the CTIA for proper presentation of results.

Ensuring MIMO Device Performance with Over-the-Air Testing

The CTIA MIMO OTA Authorization Process



The authorization process begins after CTIA publishes their current version of the test plan and then their Authorized Validation Requirements Document (AVRD), which defines authorization steps for system vendors and test labs and provides a template for reporting measurement uncertainty results.

After publishing these required documents, the next step is to authorize test system providers. This requires the on-site participation of a Subject Matter Expert (SME) and the submission of documents providing evidence of compliance by the system providers. This documentation includes data for MIMO OTA system validation results, a system configuration description, and example test data for all equipment configurations. System providers must also show baseline parameter file setups that have been verified for test plan compliance. Once these steps are complete, validated configurations for hardware and software are published as being authorized by the CTIA.

In addition, each test lab must be authorized. Labs are required to be accredited to ISO 17025 accreditation. The lab must also have been previously authorized by the CTIA for SISO OTA testing for the same chamber that is going to be used for MIMO OTA testing. This allows for an off-site review by a SME for adding the MIMO OTA testing scope. Labs must submit work instructions, test setup information for previously authorized equipment (identified above), sample test reports, and a measurement uncertainty test report for SME review.

Once documentation for all of these requirements is approved, the lab receives CTIA authorization, thus becoming a CTIA Authorized Test Lab (CATL) for MIMO OTA.

The final step in the rollout process is the authorization of a critical mass of CATLs, at which point the current version becomes mandatory for CTIA and PTCRB certification.

Conclusion

OTA testing is a critical aspect of MIMO device performance evaluation. The ability to examine MIMO antenna performance in realistic propagation environments enables an accurate view of the user experience and can help operators ensure a high QoE is delivered.

Spatial channel emulation is an essential part of MIMO OTA testing and Spirent experts are long-time contributors to the CTIA OTA working groups. It is this industry-recognized expertise that is the foundation of Spirent's test solutions spanning MIMO OTA and A-GNSS OTA test requirements. For MIMO OTA, Spirent provides a robust channel emulation solution with the newer Vertex® spatial channel emulator and the prior VR5 platform, which was utilized in the MIMO OTA Signals Research Study discussed in this paper.

Both Vertex and VR5 support the current CTIA MIMO OTA Test Plan. Vertex will continue to evolve in capability to align with requirements defined in future versions. Delivering high channel density capacity, a single Vertex instrument populated at half capacity can support the 2x16 configuration needed for the current CTIA MIMO OTA test plan, with a fully populated unit supporting a 2x32 MIMO OTA anechoic chamber configuration.

As wireless networks advance toward 5G and massive MIMO applications, the scope of device testing will rapidly increase in complexity and drive the demand for test solutions that are capable of scaling to support test requirements for higher channel density configurations.

To address this need, Spirent applied its expertise into developing Vertex, a next-generation platform that easily scales to support the complexity and high-channel density scenarios required for 5G. With its compact form factor and unique modular approach, Spirent Vertex is positioned to help developers deliver higher data rates, more robust coverage and enhanced QoE for next-generation services.

Ensuring MIMO Device Performance with Over-the-Air Testing

About Spirent Communications

Spirent Communications (LSE: SPT) is a global leader with deep expertise and decades of experience in testing, assurance, analytics and security, serving developers, service providers, and enterprise networks.

We help bring clarity to increasingly complex technological and business challenges.

Spirent's customers have made a promise to their customers to deliver superior performance. Spirent assures that those promises are fulfilled.

For more information, visit:
www.spirent.com



Contact Us

For more information, call your Spirent sales representative or visit us on the web at www.spirent.com/ContactSpirent.

www.spirent.com

© 2018 Spirent Communications, Inc. All of the company names and/or brand names and/or product names and/or logos referred to in this document, in particular the name "Spirent" and its logo device, are either registered trademarks or trademarks pending registration in accordance with relevant national laws. All rights reserved. Specifications subject to change without notice.

Americas 1-800-SPIRENT
+1-800-774-7368 | sales@spirent.com

US Government & Defense
info@spirentfederal.com | spirentfederal.com

Europe and the Middle East
+44 (0) 1293 767979 | emeainfo@spirent.com

Asia and the Pacific
+86-10-8518-2539 | salesasia@spirent.com